



Catalog 1610-8

Daikin Classroom Unit Ventilators
Models AHF, AHB, AHV and AHR Ceiling Units
MicroTech® Control ("J" Vintage)



AH Unit

| | | | |
|---|-----------|--|------------|
| Introduction | 4 | Wall Louvers | 50 |
| Daikin Classroom Unit Ventilators | 4 | Wall Intake Louvers & Grilles | 50 |
| AHRI Performance | 5 | VentiMatic Shutter | 51 |
| Features & Benefits | 6 | VentiMatic Shutter Assembly | 51 |
| Quiet Operation With Our GentleFlo Delivery | 7 | Performance and Selection | 52 |
| Precise Temperature and Dehumidification Control | 9 | Quick Selection Procedure | 52 |
| Low Operating Costs | 12 | Chilled Water Selection Example | 54 |
| Easy To Maintain | 13 | Hot Water Heating Selection | 56 |
| Easy Access Doors and End Panel | 13 | Quick Selection Method Using MBH/ Δ T | 56 |
| Built To Last | 14 | Two-Pipe Chilled-Water/Hot-Water | |
| Standard EC Motor | 15 | Applications | 56 |
| General Data | 16 | Steam Heating Selection | 60 |
| Model Nomenclature | 16 | Electric Heating Selection | 61 |
| Model Types | 18 | Direct Expansion Cooling Coil Selection | 61 |
| Available Unit Ventilator Combinations | 19 | Electrical Data | 62 |
| Discharge Air Arrangements | 22 | Wiring Diagrams | 63 |
| Intake Air Arrangements | 23 | Typical Wall Sensors Diagram | 65 |
| MicroTech Controls For Superior Performance, Easy | | Power & Control Field Wiring | 66 |
| Integration | 24 | Typical Digital Ready Wiring Diagram | 68 |
| Digital Ready Systems | 25 | Typical Controls By Others Wiring Diagram | 69 |
| Field Mounted Controls (By Others) | 25 | MicroTech Controls | 71 |
| Economizer Modes | 25 | Control Modes and Functions | 71 |
| Demand Control Ventilation | 25 | Advanced Control Options | 73 |
| Accessories | 26 | System Components | 74 |
| Wall Louvers & Grilles | 26 | Unit Ventilator Controller | 74 |
| VentiMatic™ Shutter – Room Exhaust Ventilation | 27 | Actuators | 77 |
| Details & Dimensions | 28 | Application Considerations | 79 |
| Physical Data | 28 | Why Classrooms Overheat | 79 |
| Arrangement AT: 36" Deep Unit Front Discharge with | | Meeting IAQ Requirements | 80 |
| Double-Deflection Grille | 29 | Following ASHRAE Control Cycle II | 81 |
| Arrangement AH: 36" Deep Unit Front Discharge with Duct | | Meeting AHRI 840 Requirements | 82 |
| Collar | 30 | Face & Bypass Temperature Control | 83 |
| Arrangement BD: 40" Deep Unit Bottom Discharge with | | Modulating Valve Temperature Control | 85 |
| Double-Deflection Grille | 31 | Coil Selection | 86 |
| Arrangement FD: 40" Deep Unit Front Discharge, Double | | DX Split Systems | 87 |
| Deflection Grille (2000 cfm only) | 32 | Digital Ready Systems | 89 |
| Arrangement FD: 40" Deep Unit Front Discharge with Duct | | Field-Installed Controls By Others & | |
| Collar (2000 cfm only) | 33 | Digital Ready Controls | 89 |
| Coil Connections | 34 | Unit Installation | 95 |
| Heat/Cool Units (Right Hand) | 35 | Unit Arrangements | 96 |
| Reheat Units (Right Hand) | 37 | Duct System Applications | 98 |
| Heating Only Units | 39 | Duct System Design | 98 |
| Cooling Only Units (Right Hand) | 40 | Wall Louvers | 101 |
| Condensate Drain Connections | 40 | Valve Selection | 103 |
| Valves | 41 | Face and Bypass End-Of-Cycle Valve Sizing & Piping | 103 |
| Face & Bypass End of Cycle Valves | 41 | Modulating Valve Sizing & Piping | 105 |
| 2-Way Modulating Valve (Chilled Water, Hot Water or | | Steam Valve Sizing & Piping | 107 |
| Combination) | 42 | Guide Specifications | 109 |
| 2-Way Modulating Valve (Steam) - 1/2" | 44 | Daikin Applied Unit Ventilator – Model AH Guide | |
| 2-Way Modulating Valve (Steam) - 3/4" | 46 | Specifications | 109 |
| 3-Way Modulating Valve (Chilled Water, Hot Water or | | | |
| Combination) | 48 | | |

Daikin Classroom Unit Ventilators



For nearly a century schools have relied on unit ventilators to keep classrooms comfortable. Students learn more readily in a quiet, well-ventilated environment. That is why Herman Nelson invented the unit ventilator in 1917. Daikin Applied continues to set the industry standard for performance, features and quality. Today Daikin remains committed to continuing the Herman Nelson-AAF-McQuay legacy as the industry leader and meeting the changing requirements of schools with the highest quality unit ventilator products available.

We realize that keeping expenditures down is a high priority for school administrators and school boards.

Daikin unit ventilators are inexpensive to install and operate, and they are designed and built to provide decades of trouble-free service.

Quiet Operation

Daikin unit ventilators are engineered and manufactured to deliver quiet, continuous comfort. We developed our GentleFlo™ air moving system to minimize operating sound levels—even as demands for more fresh air require units to operate longer and work harder.

The Right Amount of Fresh Air and Cooling

Daikin unit ventilators deliver required amounts of fresh air to meet ventilation requirements, and added cooling capacity to maintain consistent comfort for students and teachers. Our Economizer Operation, Demand Control Ventilation (DCV) and Part Load, Variable Air options allow you to closely match comfort requirements and reduce operating costs.

Precise Temperature and Dehumidification Control

Daikin unit ventilators feature precise temperature and dehumidification control to keep students and teachers comfortable while making maximum use of “free” outdoor-air cooling to reduce operating costs. They utilize a draw-thru air design that contributes to even

heat transfer and uniform discharge air temperatures into the classroom. Coupled with face and bypass air control and our MicroTech® active and passive dehumidification control strategies, they provide precise control of temperature and humidity levels.

Low Installation Costs

New construction installations are easily accomplished with Daikin unit ventilators because they avoid the added cost and space required for expensive ductwork. Retrofit installations are also economical because new units fit the same space occupied by existing ones. Multiple control options—including: MicroTech controls with Protocol Selectability™, or Digital Ready™ features—provide easy, low cost integration into the building automation system of your choice.

Low Operating Costs

When running, Daikin unit ventilators can use as little electricity as two 100-watt light bulbs. They take maximum advantage of “free” cooling opportunities to reduce operating costs. During unoccupied periods and at night, units operate sparingly to conserve energy.

Easy To Maintain, Modular Design

Daikin Unit Ventilators are designed to provide easy access for maintenance and service personnel to all serviceable components. Most tasks are easily handled by a single person.

Built To Last

Our proven institutional design can withstand the rigors of the classroom environment. It features an extra-sturdy chassis and double-wall damper on the inside; scuff-resistant finishes and tamper prevention features on the outside. In fact, many units installed over 30 years ago continue to provide quiet, reliable classroom comfort.

MicroTech® Control For Superior Performance, Easy Integration

Daikin unit ventilators can be equipped with MicroTech® unit controllers for superior performance. Factory integrated and tested controller, sensor, actuator and unit options promote quick, reliable start-up and minimize costly field commissioning. Our Protocol Selectability feature provides easy, low-cost integration into most building automation systems. MicroTech controls have on-board BACnet® communications, with optional LON-TALK® to communicate control and monitoring information to your BAS, without the need for costly gateways. Unit controllers are LON-MARK® certified with the optional LON-WORKS® communication module.

AHRI Performance

Table 1: AHRI Performance Data

| Model | Unit Size | Nominal Airflow | | Cooling Coil Rows | Total Capacity | | Sensible Capacity | | Temperature Rise | | Power Input | Ventilation Rate |
|------------|-----------|-----------------|-----|-------------------|----------------|-------|-------------------|-------|------------------|------|-------------|------------------|
| | | CFM | L/s | | Btuh | Watt | Btuh | Watt | F | C | Watts | % |
| AHV AHF | H07, V07 | 750 | 354 | 2-Row | 15700 | 4601 | 11400 | 3341 | 10 | 12.2 | 216 | 80 |
| | | | | 3-Row | 19000 | 5568 | 12900 | 3781 | | | 212 | |
| | | | | 4-Row | 24500 | 7180 | 15300 | 4484 | | | 207 | |
| | | | | 5-Row | 30800 | 9027 | 20300 | 5949 | | | 203 | |
| | H10, V10 | 1000 | 472 | 2-Row | 23600 | 6916 | 17800 | 5217 | 10 | 12.2 | 277 | 80 |
| | | | | 3-Row | 33200 | 9730 | 22600 | 6623 | | | 277 | |
| | | | | 4-Row | 35600 | 10433 | 23300 | 6829 | | | 279 | |
| | | | | 5-Row | 35900 | 10521 | 23600 | 6916 | | | 280 | |
| | H13, V13 | 1250 | 590 | 2-Row | 31500 | 9232 | 23600 | 6916 | 10 | 12.2 | 335 | 80 |
| | | | | 3-Row | 41000 | 12016 | 28600 | 8382 | | | 331 | |
| | | | | 4-Row | 43300 | 12690 | 28700 | 8411 | | | 327 | |
| | | | | 5-Row | 47200 | 13833 | 31100 | 9115 | | | 323 | |
| | H15, V15 | 1500 | 708 | 2-Row | 38700 | 11342 | 28400 | 8323 | 10 | 12.2 | 445 | 80 |
| | | | | 3-Row | 51200 | 15005 | 34900 | 10228 | | | 431 | |
| | | | | 4-Row | 56700 | 16617 | 37100 | 10873 | | | 418 | |
| | | | | 5-Row | 57600 | 16881 | 36800 | 10785 | | | 380 | |

Notes: 1. Rated in accordance with AHRI Standard 840-98 for Unit Ventilators.

2. Capacity is based on 80°F db, 67°F wb entering air temperature, 45°F enter water temperature and high-speed fan.

3. Data for 2000 CFM unit not available at time of publication. See Figure 79 through Figure 82 for 2000 CFM performance



Ventilation rate certified and tested per Air Conditioning, Heating and Refrigeration Institute (AHRI) Standard 840.



Model AH Ceiling Unit Features

Our Model AH is a horizontal, ceiling-mounted unit that is designed for rooms where floor space is at a premium. It utilizes remotely-supplied chilled water or refrigerant for cooling, and hot water, steam or electric heat for heating. It also can be supplied as a cooling/ventilating unit only or as a heating/ventilating unit only with the option of adding cooling at a later date.

The Model AH is just right for new construction and for retrofit applications. It can be installed with a variety of

exposures, including completely exposed, partially or fully recessed, or completely concealed. Older buildings with baseboard radiant heat or other hydronic heating systems can be easily adapted to work efficiently with Model AH units. Chilled-water or refrigerant cooling can be added to provide year-round comfort.

The major features of this model are shown and described in more detail on the following pages.

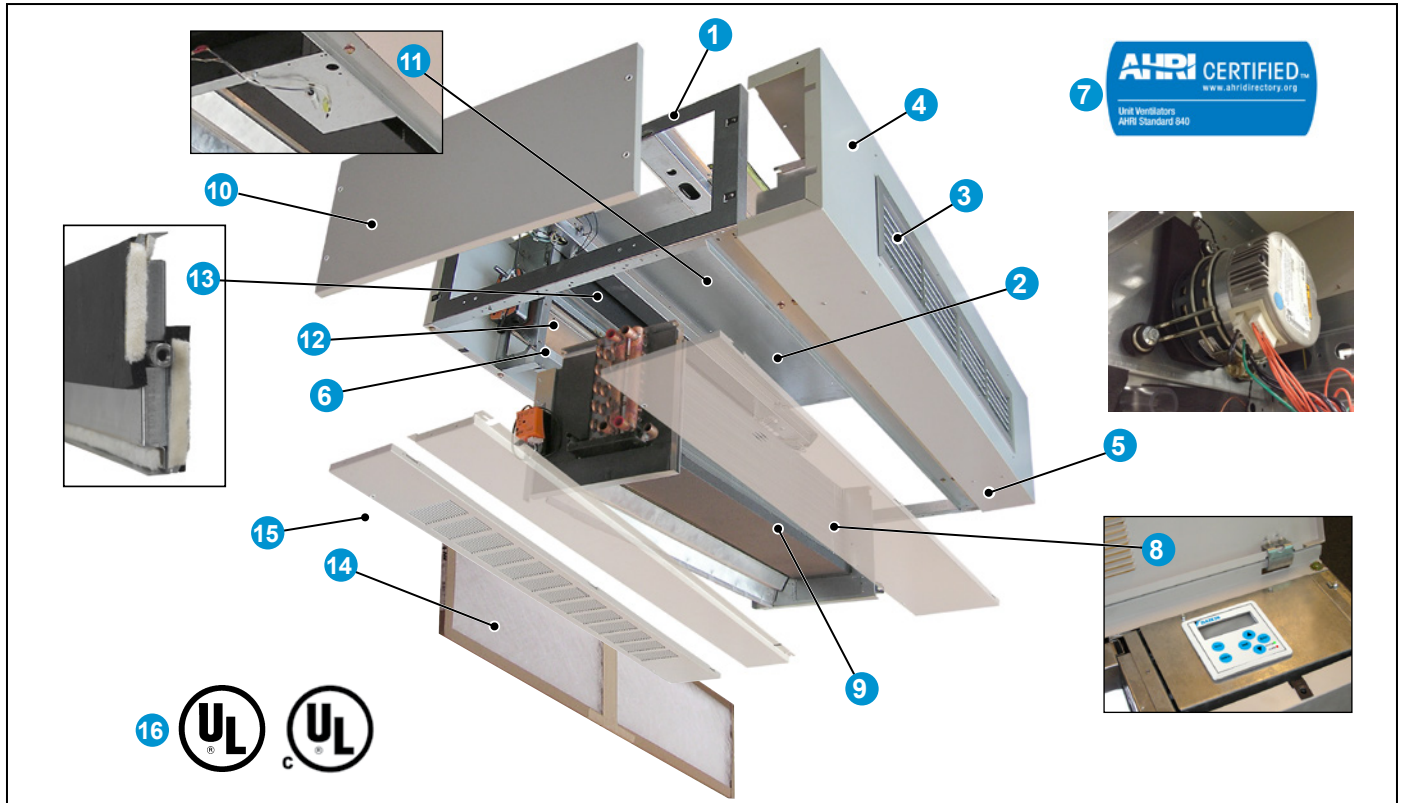

- | | | |
|---|---|---|
| <p>1 Welded one-piece chassis</p> <ul style="list-style-type: none"> • offers superior strength, durability, and vibration reduction. <p>2 Unique draw-thru design</p> <ul style="list-style-type: none"> • provides uniform air distribution across the coil for even discharge air temperatures. <p>3 Quiet, aerodynamic fans</p> <ul style="list-style-type: none"> • utilize GentleFlo technology for exceptionally quiet unit operation. <p>4 Modular fan section</p> <ul style="list-style-type: none"> • improves balance, alignment and simplifies maintenance. <p>5 EC fan motor</p> <ul style="list-style-type: none"> • located out of air stream and away from heating coil, reduces heat exposure to prolong life. • self-adjusts to low or high static installations | <p>6 Face and bypass damper design</p> <ul style="list-style-type: none"> • provides superior dehumidification and reduces chance of coil freeze-up <p>7 Certified ventilation performance</p> <ul style="list-style-type: none"> • per AHRI-840. <p>8 MicroTech controls (optional)</p> <ul style="list-style-type: none"> • provide superior comfort control and easy integration into the building automation system of your choice. <p>9 Advanced heat transfer coil</p> <ul style="list-style-type: none"> • design provides extra capacity. <p>10 Easy access for service</p> <ul style="list-style-type: none"> • Easy bottom & side panel removal for access to piping, drain pan and controls. | <p>11 Sampling chamber</p> <ul style="list-style-type: none"> • unit-mounted sensor provides accurate sensing of room temperature. <p>12 Indoor room air damper</p> <ul style="list-style-type: none"> • blocks unwanted gusts of outdoor air on windy days. Its nylon bearings are quiet and maintenance free. <p>13 Insulated double-wall outdoor air damper</p> <ul style="list-style-type: none"> • seals tightly without twisting. <p>14 Single full-length air filter</p> <ul style="list-style-type: none"> • is efficient and easy to replace. All air delivered to classroom is filtered. <p>15 Single door access to air filter</p> <ul style="list-style-type: none"> • makes replacement easy. <p>16 UL/cUL listed</p> |
|---|---|---|

Quiet Operation With Our GentleFlo Delivery

Daikin unit ventilators are engineered and manufactured to deliver quiet, continuous comfort. We developed our GentleFlo™ air moving system to minimize operating sound levels—even as demands for more fresh air require units to operate longer and work harder. GentleFlo features include:

- Fan wheels are large, wide and rotate at a low speed to reduce fan sound levels. They are impact-resistant and carefully balanced to provide consistent performance.
- Offset, aerodynamic fan wheel blades move air efficiently (Figure 2).
- Precision tolerances help reduce flow and pressure turbulence, resulting in lower sound levels.

- A large, expanded discharge opening minimizes air resistance, further lowering sound levels.
- Fan housings incorporate the latest logarithmic expansion technology for smoother, quieter air flow (Figure 2).
- Modular fan construction contributes to equal outlet velocities and promotes quiet operation.
- Fan shafts are of ground and polished steel to minimize deflections and provide consistent, long-term operation.
- Fan assemblies are balanced before unit assembly, then tested after assembly (and rebalanced if necessary) to provide stable, quiet operation.

Figure 2: GentleFlo Fan Technology

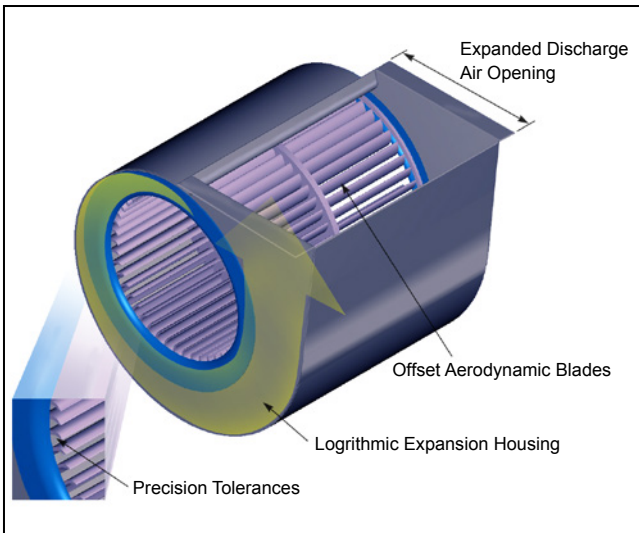
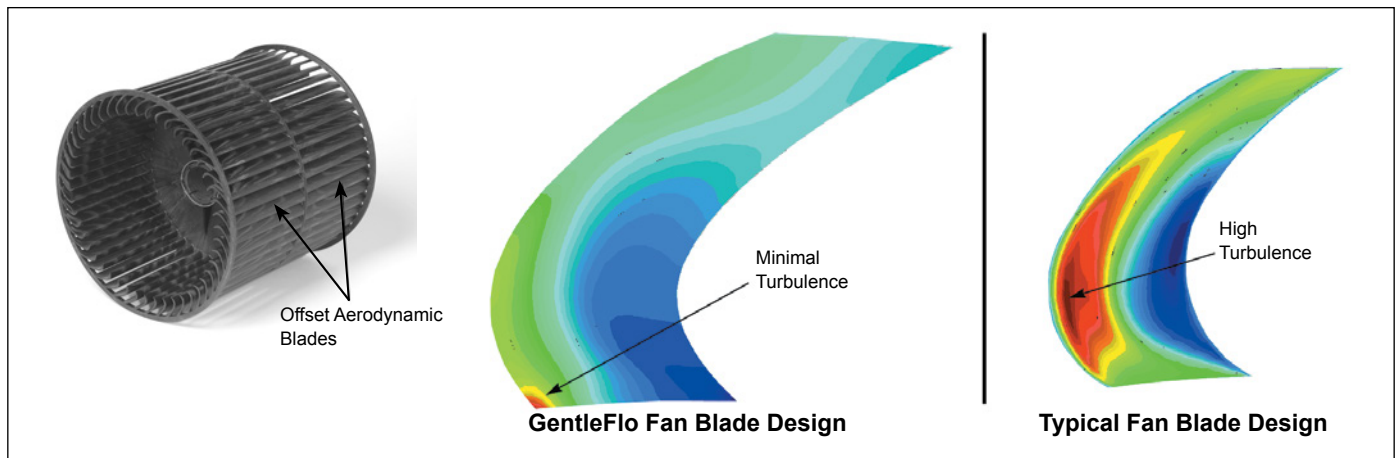

Figure 3: GentleFlo Reduces Turbulence



The Right Amount of Fresh Air and Cooling

Daikin unit ventilators deliver required amounts of fresh air to meet ventilation requirements and added cooling capacity to maintain consistent comfort for students and teachers. Our Economizer Operation, Demand Control Ventilation (DCV) and Part Load, Variable Air options allow you to match classroom comfort requirements even more closely, and reduce operating costs.

This means that you can be confident that your school is meeting ventilation standards for Indoor Air Quality and that your students are receiving adequate air to be attentive to instruction. At the same time, you are saving money in early morning hours, between classes or after hours when classrooms are heated and cooled but not always fully occupied.

Economizer Operation

It is well recognized that cooling, not heating, is the main thermal challenge in school classrooms. The typical classroom is cooled by outdoor air over half the time, even in cold climates. It is therefore essential that unit ventilators efficiently deliver outdoor air when classroom conditions call for “free” or economizer cooling.

With Daikin unit ventilators, you can have outdoor air whenever it is needed. Economizer operation is facilitated by the outdoor air damper, which automatically adjusts the above-minimum outside air position to provide free cooling when the outdoor air temperature is appropriate (Figure 4). On units equipped with MicroTech controls, three levels of economizer control are available (see page 70).

Figure 4: Full Economizer Mode

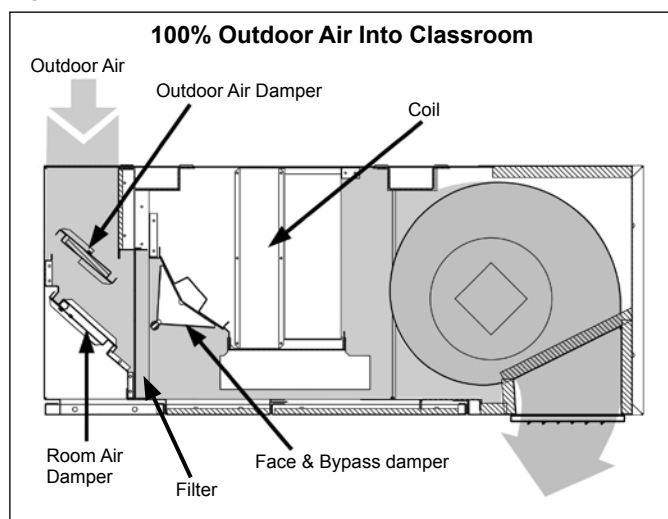

Part-Load Variable Air Control

Part Load Variable Air control can be used in conjunction with face and bypass damper temperature control to automatically adjust the unit ventilator fan speed based upon the room load and the room temperature. The MicroTech control option provides higher latent cooling capabilities and quieter operation during non-peak load periods by basing indoor fan speed upon room load.

Lower fan speeds in conjunction with our GentleFlo fan technology (see page 6) contributes to a very quiet classroom environment.

Room-temperature PI control loops determine the speed of the fan, which varies according to the room load. It also provides a built-in delay to prevent overshooting for better comfort control. The outdoor air damper’s minimum-air position is adjusted with the fan speed to bring in a constant amount of fresh air.

Demand Control Ventilation

Daikin unit ventilators can be equipped to use input from a CO₂ controller to ventilate the space based on actual occupancy instead of a fixed design occupancy. This Demand Controlled Ventilation (DCV) system monitors the amount of CO₂ so enough fresh outdoor air is introduced to maintain good air quality. The system is designed to achieve a target ventilation rate (e.g., 15 cfm/person) based on actual occupancy.

By using DCV to monitor the actual occupancy pattern in a room, the system can allow code-specific levels of outdoor air to be delivered when needed. Unnecessary over-ventilation is avoided during periods of low or intermittent occupancy, leading to improved energy efficiencies and cost savings.

Precise Temperature and Dehumidification Control

Daikin unit ventilators provide precise temperature and dehumidification control to keep students and teachers comfortable while making maximum use of “free” outdoor-air cooling to reduce operating costs. They utilize a draw-thru fan design that contributes to even heat transfer and provides uniform discharge air temperatures into the classroom. Coupled with face and bypass damper air control and/or our MicroTech active and passive dehumidification control strategies, they provide precise control of temperature and humidity levels under both part-load and full-load conditions.

Draw-Thru Design For Even Discharge Temperatures

The Draw-Thru design sets our unit ventilators apart from most competitive models. With this system, fans draw air through the entire heat transfer element (Figure 5) rather than blowing it through highly concentrated areas of the coil element. The result is more uniform discharge air temperatures into the classroom and more efficient unit ventilator operation.

Figure 5: Draw-Thru Design Provides Even Discharge Air

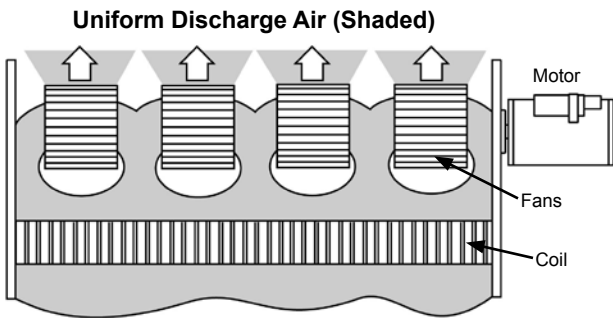

Face & Bypass Design For Better Temperature and Humidity Control

When coupled with our draw-thru design, face and bypass damper air control offers maximum dehumidification and optimal temperature control. That’s because indoor and outdoor air streams can be separated until it is optimal to mix them.

During most part-load conditions, humid outdoor air is directed through the cold coil (coil surface below the dew point) where moisture is removed. Room air is bypassed around the coil, since it has already been dehumidified. This arrangement allows for maximum condensate removal. Humid outdoor air is not bypassed around the coil until the total amount of cooling air required is less than the total amount of fresh outdoor air required in the room. Figure 6 and Figure 7 below compare the composition of the air streams through the coil and

air streams bypassing the coil at various bypass air percentages for draw-thru and blow-thru unit ventilators using 450 cfm of outdoor air. At both 0% bypass air and 100% bypass air, no difference exists in the composition of the air streams. However, at all other bypass air percentages (part load), significant differences are evident. For instance, compare the 1500 cfm draw-thru (Figure 6) and blow-thru (Figure 7) units at 70% bypass air. At this point, the draw-thru unit still has all of the outdoor air going through the coil. Meanwhile, the blow-thru unit is bypassing 70% (315 cfm) of the humid outdoor air directly into the classroom.

Figure 6: Daikin Applied 1500 CFM Draw-Thru Unit

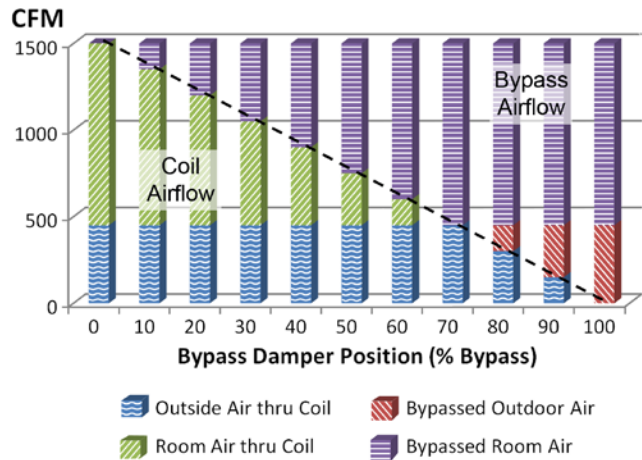
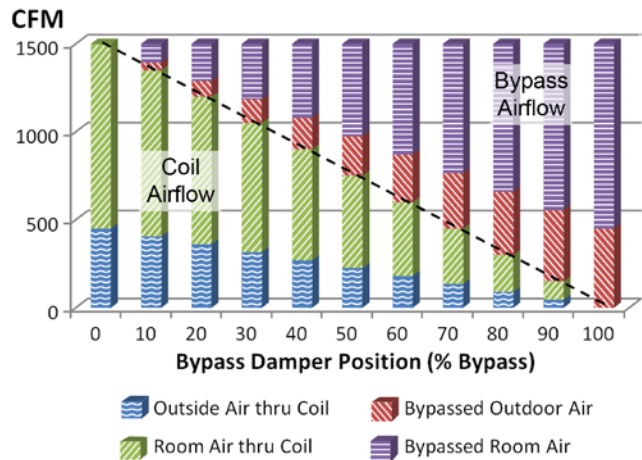

Figure 7: 1500 CFM Typical Blow-Thru Design



This illustrates that the most effective way to maintain an acceptable humidity level with a chilled-water unit ventilator system is to use a face and bypass damper, draw-thru unit.

Why Blow-Thru Designs Don't Measure Up

Blow-thru designs cannot provide comfort like this. With blow-thru designs, the humid outside air is pre-mixed with the room air before it can go through the coil (Figure 8). Dehumidification occurs only to the portion of the air that is directed unevenly through the cooling coil. The air that bypasses the coil is largely humid outdoor air, resulting in unconditioned air being bypassed and creating poor comfort conditions.

Figure 8: Blow-Thru Vs. Draw-Thru Design

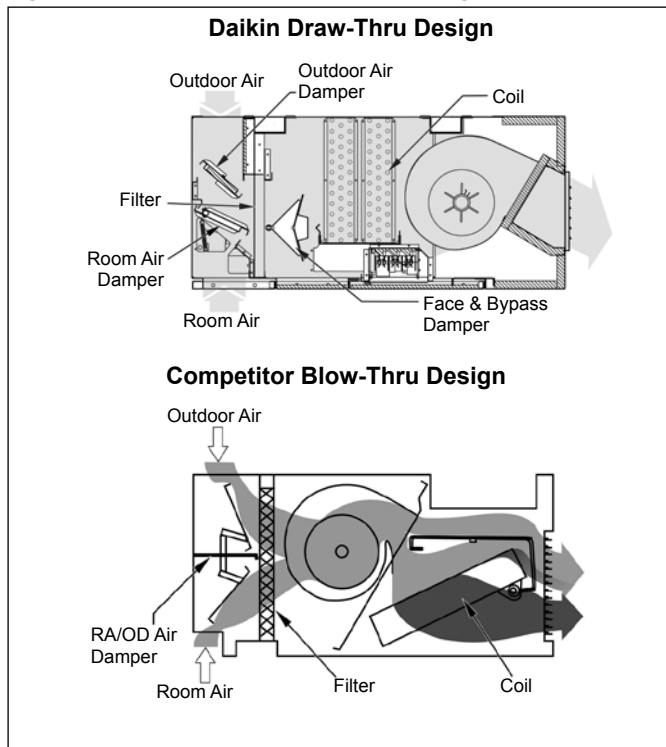

With a blow-thru design the positive pressure of the fan discharge can create areas across the coil of varying temperatures and airflow. In addition, blow-thru face and bypass damper construction picks up heat by wiping the coil, creating overheating conditions. The sound level in a blow-thru design also varies based upon the position of the face and bypass damper.

Active Dehumidification (Reheat)

In high-humidity applications where valve-controlled, reheat units are used, the Active Dehumidification Control (ADC) sequence should be considered. During excessive humidity conditions, a humidity sensor directs the unit to continue cooling past the room setpoint to remove excess moisture. Hydronic heat or electric heat is then used to reheat the discharge air to maintain acceptable room temperatures.

MicroTech controls minimize the amount of reheat needed to maintain relative humidity below a preset limit. Reheat is used only when required and in the most energy-efficient manner possible. See "Active Dehumidification Control (Reheat)" on page 72 for more information.

Passive Dehumidification (Optional)

On units with face and bypass damper air control and MicroTech part-load variable air control, passive dehumidification can be used under high humidity conditions to keep classrooms comfortable. A unit mounted humidity sensor and fan speed changes are utilized to improve latent cooling by keeping the air in closer contact with the cold coil for passive dehumidification.

This occurs in the unoccupied mode as the unit operates to satisfy the unoccupied temperature and humidity set points with the outside damper closed. The face and bypass damper is placed in a minimum face position to promote high latent cooling. The unit fan continues to operate on low speed until the load is satisfied. This is very helpful in high humidity areas where high night time humidity can be absorbed in the building during off hours.

Increased Coil Freeze Protection

Daikin units equipped with face and bypass damper control provide extra protection from coil freeze-up. That's because there is a constant flow of hot water through the coil, and water that is flowing typically does not freeze. Additionally, all Daikin Applied units feature a double-walled, insulated outdoor air damper with airtight mohair seals to prevent unwanted coil air from entering the unit.

Furthermore, a low-temperature freezestat is factory installed on all units with hydronic coils. Its serpentine capillary tube senses temperatures across the leaving air side of the coil, allowing the unit controller to react quickly to low-temperature conditions.

Figure 9: Freezestat

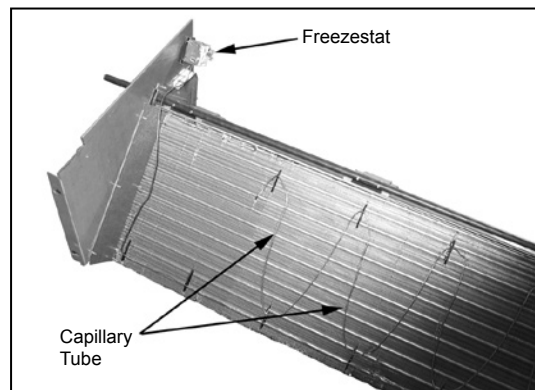

Low Installation Costs

Daikin unit ventilators have many features that make them economical to purchase and to install in both new construction and retrofit applications. It is this attention to detail and understanding of school applications that make them the system of choice.

Perfect For Both New & Retrofit Applications

New construction installations are easily accomplished with Daikin unit ventilators because they avoid the added cost and space required for expensive ductwork. Further savings can be realized because piping installations use less space than duct systems.

This is important in existing buildings and also in new construction where floor-to-floor heights can be reduced, saving on overall building costs.

Retrofit installations are also economical because new units fit the same space occupied by existing ones. Using Daikin Applied unit ventilators, central equipment, such as chillers, can be sized smaller using building diversity. This results in a low capital-cost system.

Built In Flexibility

Daikin unit ventilators include features that make them easy to set up and reconfigure as needed to meet special requirements. These features include:

- **Reversible Drain Connections:** All units come with a galvanized steel drain pan that has drain connections on either end (Figure 10). A secondary, overflow drain connection is also provided. The drain-side connection can be selected in the field. The direction in which the drain pan slants can also be field-modified.

Figure 10: Drain Pan, Reversible Connections

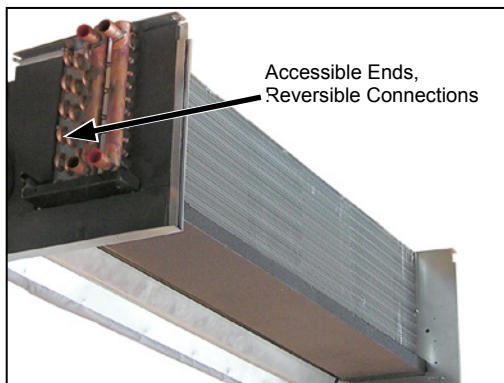

- **Add Cooling At A Later Date:** Because we recognize that some schools may wish to add cooling at a later date, even heating-only units are shipped standard with a composite drain pan.

- **Built-In Wire Race:** A built-in metal wire race runs from one end of the unit to the other to provide extra protection for wires and protect them from unit air.
- **Adjustable, Double-Deflection Discharge Grille:** Units with front and bottom discharge come standard with four-way, double-deflection discharge grilles (Figure 11). This allows air distribution patterns to be adjusted both vertically and horizontally on the job, to meet room requirements.

Figure 11: Double-Deflection Discharge Grille

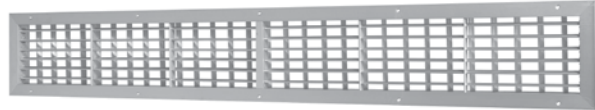

- **Finished Appearance:** Units can be mounted in an exposed position, in a soffit, partially recessed, fully recessed or concealed (Figure 12). For fully and partially recessed units, recess flanges are a standard accessory (Figure 13). These provide a finished appearance and a break to isolate the unit from the ceiling.

Figure 12: Exposures

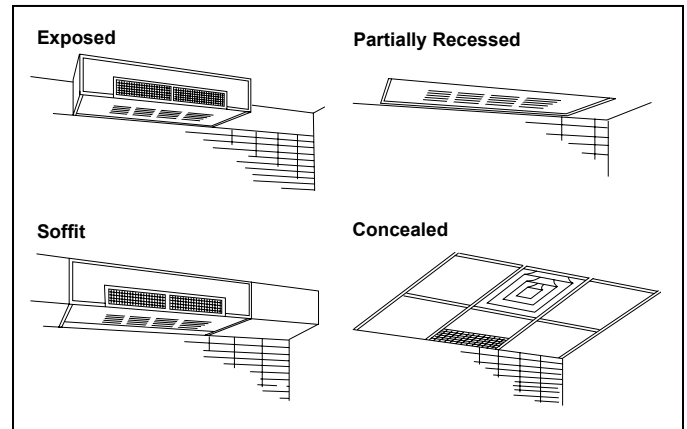
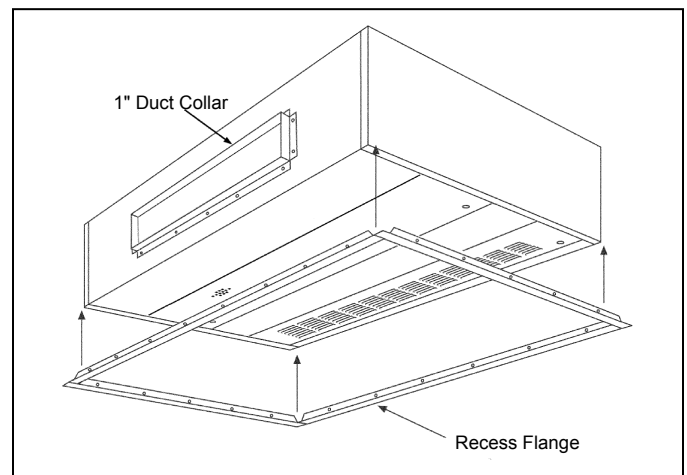

Figure 13: Recess Flange



Controls Flexibility

Multiple control options—including MicroTech controls with our Protocol Selectability feature—provide easy, low cost integration of Daikin unit ventilators into the building automation system of your choice (see "[MicroTech® Controls \(Optional\)](#)" on page 23). You can also operate these units individually or in a server-client control configuration.

MicroTech controls come with on-board BACnet MS/TP communications with the option for LON^{TALK} to communicate control and monitoring information to your BAS, without the need for costly gateways. Unit controllers are LON^{MARK} certified with the optional LON^{WORKS} communication module.

Controls and communication modules can be factory provided or field-installed by others. Factory integrated and tested controller, sensor, actuator and unit options promote quick, reliable start-up and minimize costly field commissioning.

You can also use our Digital Ready option, where we factory-install and pre-wire control sensors and actuators and the controller is field-installed by others. See "[Digital Ready Systems](#)" on page 24.

Low Operating Costs

Schools consume more than 10% of the total energy expended in the United States for comfort heating and cooling of buildings. As energy costs increase, educators are placed in a difficult position: caught between rising costs, lower budgets and the requirements to raise educational standards. Fortunately, the technology and the system exists for schools to take control of their energy expenditures while providing a comfortable environment for learning. And that system is the Daikin Applied unit ventilator.

Consider these realities of school environments:

- Most heating energy in schools is expended to heat unoccupied spaces. Because lights, computers and students give off considerable heat, occupied spaces require little supplemental heat.
- The removal of heat is usually required in occupied classrooms, even when outside temperatures are moderately cold (i.e., 35-40°F).

Then consider how Daikin unit ventilators, located in

each classroom, take advantage of these realities to lower operating costs:

- They provide individual classroom control and comfort.
- They can be cycled on when the room is occupied and cycled off when it is not.
- They bring in fresh air from directly outside the classroom for high indoor air quality.
- During most of the school year, they use outdoor air to keep classrooms comfortable without the expense of mechanical cooling.
- They have their own air-moving device—a fan and fractional horsepower motor—which uses about as much energy as two 100-watt light bulbs. Compare this to the energy consumed by the 20-plus-hp motors used in centralized systems to cool both occupied and unoccupied spaces (at about 1 hp of energy consumed per room).

MicroTech Control Options Further Reduce Operating Costs

Many of the MicroTech control options available with Daikin Applied unit ventilators can further reduce operating costs. For example:

- **Economizer Operation:** Economizer operation automatically adjusts the above-minimum outside air position to provide free cooling when the outdoor air temperature is appropriate.
- **Demand Control Ventilation:** By using CO₂ levels to monitor the actual occupancy pattern in a room, the system can allow code-specific levels of outdoor air to be delivered when needed without costly over-ventilation during periods of low or intermittent occupancy ([Figure 14](#)).
- **Occupancy Mode Operation:** Units can be programmed to operate only sparingly during unoccupied periods and at night to conserve energy.

Figure 14: Energy Savings with Demand Control Ventilation

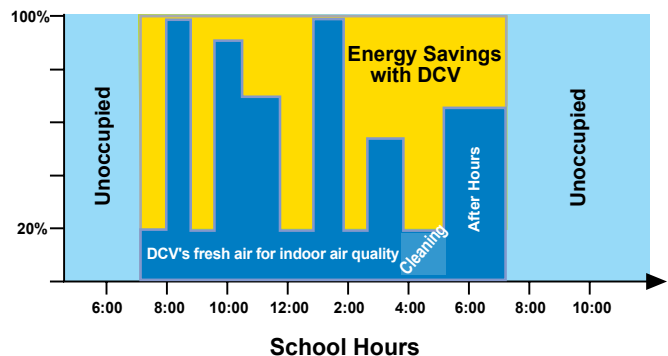

Easy To Maintain

Daikin Unit Ventilators are designed to provide easy access for maintenance and service personnel to all serviceable components. Most maintenance tasks are easily handled by a single person.

Modular Fan Deck

The entire fan deck is easily removed as a single unit. This provides ready access to fan wheels, motors, bearings and other components for service, cleaning or repair.

Figure 15: Modular Fan Deck

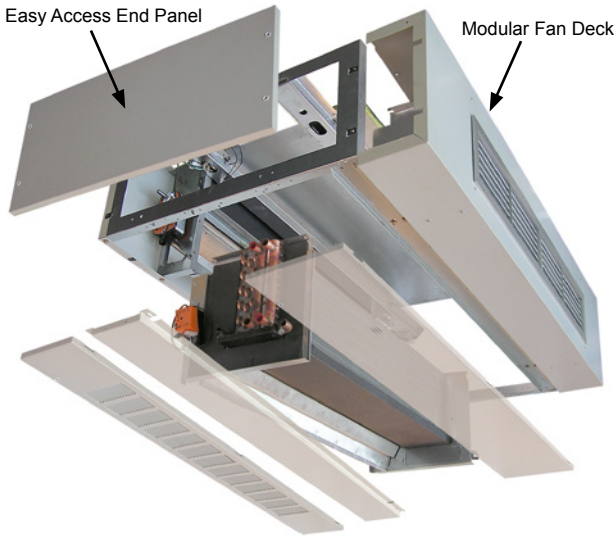

The fan deck's rotating element has one large, self-aligning, end bearing and a permanently lubricated motor bearing for smooth operation. On most sizes the location of the fan shaft bearing is at the end of the shaft (out of the air stream). This enables easy access for oiling on units built with an oilable end bearing (some units built with permanently sealed end bearings).

Figure 16: Long-Life Bearings



Permanently Lubricated Motor Bearing

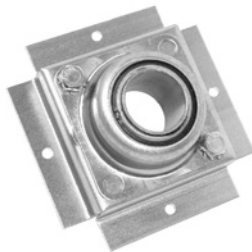

Self-Aligning, Oilable End Bearing

Easy Access Doors and End Panel

All ceiling units are equipped with hinged access doors to the filter and controls for ease of maintenance.

This enables one person to service the unit instead of a crew. Retainer chains are included to facilitate reduced access panel movement during opening.

End panels ship installed on ceiling units for a clean finish on exposed units (Figure 15) and easy access to the interior.

Figure 17: Access Door Retainer Chain

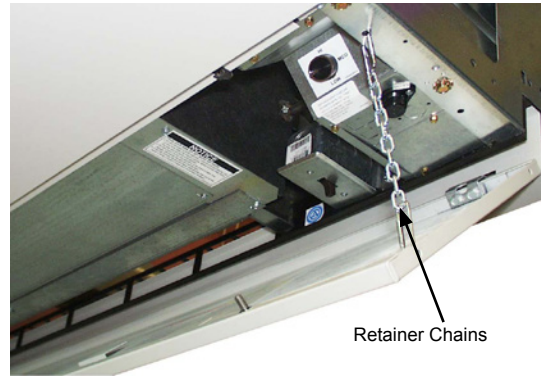

Figure 18: Easy Access To Controls

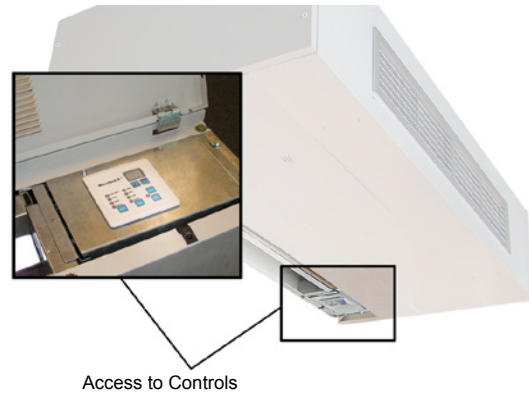

Figure 19: Easy Access For Filter Change



Single-Filter Design

With Daikin’s single-filter design, filter change-out takes only seconds. Uneven dust loading is eliminated, which is common to units with separate filters for room and outdoor air, or that use a metal partition to separate filtering of indoor and outdoor air. The result can be longer filter life, which means less maintenance and fewer filters consumed.

Three filter types are offered:

- Single-use filters which feature fiberglass media and are designed to be used once and discarded. These are standard on all but electric heat units.
- Permanent metal filters may be removed for cleaning and reused numerous times, standard on electric heat units.
- Renewable media filters, consist of a heavy-duty, painted-metal structural frame and renewable fiberglass media.

Tamper-Resistant Fasteners

Access doors are held in place by tamper-resistant, positive-positioning fasteners. They are quickly removed or opened with the proper tool, but deter unauthorized access to the unit’s interior (Figure 20).

Figure 20: Tamper-Resistant Fastener

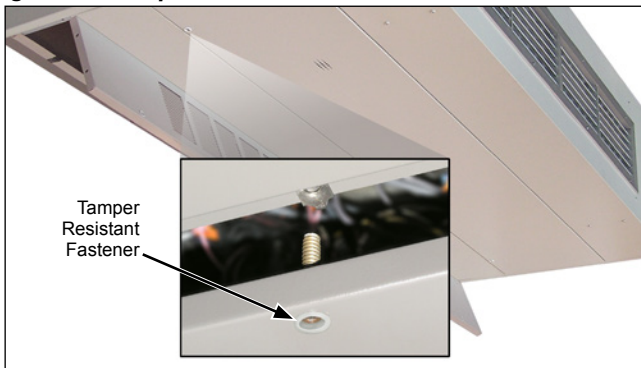

Built To Last

Our industrial-strength design provides the durability to withstand the rigors of the classroom environment. Its solid construction and rugged finish promotes continued alignment, structural strength and long-lasting beauty decades after the unit is installed. In fact, many units installed over 30 years ago continue to provide quiet, reliable classroom comfort.

Heavy Duty Frame Construction

Daikin’s exclusive, unitized frame (Figure 21) is far superior to the fastener-type construction used by other manufacturers. Loosened fasteners can cause vibration, rattles and sagging panels. With unitized construction, there are no fasteners (screws or bolts) to come loose.

Other design features that promote trouble-free operation and long life include:

- A corrosion-resistant, galvanized-steel frame.
- Hidden reinforcement that provides additional built-in support for the top section as well as better support for the fan deck assembly.

Figure 21: Heavy-Duty, Welded Chassis

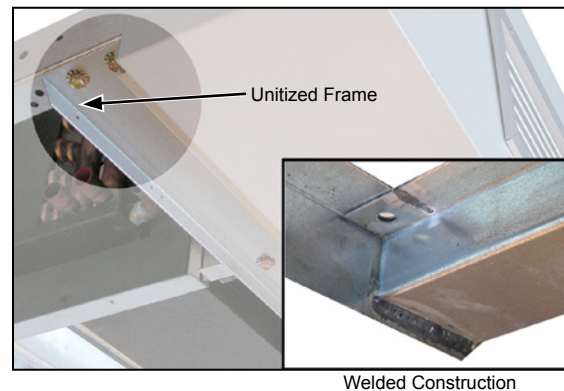

Rugged Exterior Finish

The superior finish of the unit ventilator cabinet fosters long-lasting beauty as well as resistance to abuse and corrosion. We apply the very highest standards at every step of the finishing process to provide lasting quality:

- Exterior cabinet panels are fabricated from high quality, furniture grade steel with no sharp edges.
- A specially formulated, environmentally friendly, thermosetting urethane powder is applied electrostatically to the exterior panels. This film is oven-cured to provide correct chemical cross-linking and to obtain maximum scuff and mar-resistance.
- Each unit is painstakingly inspected before boxing, then encapsulated in a clear plastic bag, surrounded by an extra-heavy-duty cardboard box and secured to a skid to help provide damage-free shipment.

Standard EC Motor

An Electrically Commutated Motor (ECM) is standard for applications up to 0.45 ESP, as [Figure 23](#) demonstrates. There is almost no draw down of the unit's airflow (cfm) as static pressures increase. As a result, there is little need to oversize the unit to provide full air volume at high static pressures.

Figure 22: EC Motor



Figure 23: EC Motor Airflow Comparison

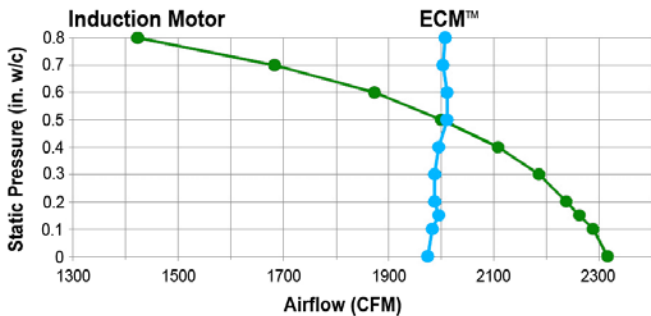

Durable Damper Design

All dampers in Daikin Unit Ventilators use the turned-metal principle on their long closing edges ([Figure 24](#)). Positive sealing is provided by embedding the edge into wool mohair (no metal to metal contact). There are no plastic gaskets to become brittle with time, sag with heat or age, or require a difficult slot fit to seal. Nylon damper bearings foster quiet, maintenance-free operation.

Additional features include:

- Face and bypass dampers have a twist-free reinforced aluminum construction for durability. Aluminum is used because it is lightweight and noncorrosive, resulting in low torque and easy movement.

- Outdoor air dampers are made of galvanized steel to inhibit corrosion, with double-wall welded construction for rigidity and encapsulated insulation ([Figure 24](#)). Additional insulation is provided on the exterior of the outdoor air damper blade and on the outdoor air entry portion of the unit.

Figure 24: Outdoor Damper Seals Out Cold Weather

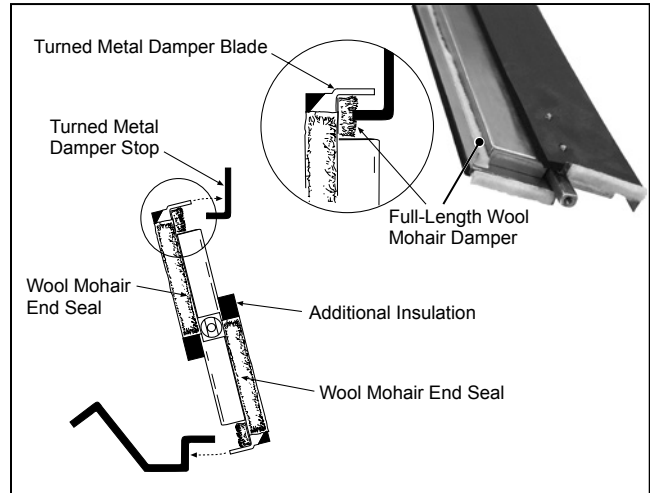

- Room air dampers are free-floating and designed to prevent intermittent gusts of cold air from blowing directly into the classroom on windy days ([Figure 25](#)). They are constructed of aluminum with built-in rigidity. The metal forming technique that is employed resists twisting and incorporates a full-length counter weight for easy rotation. The simple principle of an area exposed to a force is used to automatically close the damper, rather than open it, when gusts of cold air occur.

Figure 25: Room Air Damper Auto-Closed by Wind Gusts

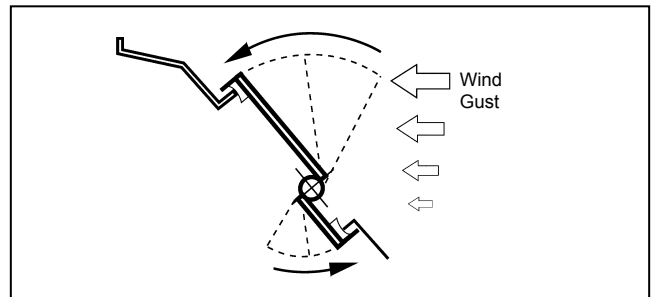

Model Nomenclature

U AHF 9 H10 A S 65 A B1 AT 26 G Y B 1
 1 2 3 4 5 6 7 8 9 10 11 12 13 14 15

| Category | Code Item | Code Option | Code Designation & Description | | | | | | | | | |
|-------------------------|------------------------------------|-------------|--------------------------------|---|---------------------|-------------------------------------|---------------------------|----|----|----|----|----|
| Product Category | 1 | 1 | U | Unit Ventilators | | | | | | | | |
| Model Type | 2 | 2-4 | AHB | Ceiling- Face & Bypass w/ Reheat | AHR | Ceiling- Valve Control w/ Reheat | | | | | | |
| | | | AHF | Ceiling- Face & Bypass | AHV | Ceiling- Valve Control | | | | | | |
| Design Series | 3 | 5 | 9 | Design J | | | | | | | | |
| Motor Type | | 6 | S | PSC Motor, 3-Speed | V | EC Motor, Variable Airflow | | | | | | |
| | | | H | EC Motor, 3-Speed | | | | | | | | |
| Nominal Capacity | 4 | 7-8 | H07 | High Static 750 CFM | V07 | EC Motor, Variable Airflow 750 CFM | | | | | | |
| | | | H10 | High Static 1000 CFM | V10 | EC Motor, Variable Airflow 1000 CFM | | | | | | |
| | | | H13 | High Static 1250 CFM | V13 | EC Motor, Variable Airflow 1250 CFM | | | | | | |
| | | | H15 | High Static 1500 CFM | V15 | EC Motor, Variable Airflow 1500 CFM | | | | | | |
| | | | H20 | High Static 2000 CFM | V20 | EC Motor, Variable Airflow 2000 CFM | | | | | | |
| Voltage | 5 | 9 | A | 115/60/1 | D | 208/60/3 | | | | | | |
| | | | C | 208/60/1 | H | 230/60/3 | | | | | | |
| | | | G | 230/60/1 | K | 460/60/3 | | | | | | |
| | | | J | 265-277/60/1 | | | | | | | | |
| Coil Options | 6 | 10 | U [1] | 2 Row CW/HW 2 pipe | V [5] | 2 Row CW | | | | | | |
| | | | D [2] | 3 Row CW/HW 2 pipe | S [6] | 3 Row CW | | | | | | |
| | | | E [3] | 4 Row CW/HW 2 pipe | W [7] | 4 Row CW | | | | | | |
| | | | F [4] | 5 Row CW/HW 2 pipe | Y [8] | 5 Row CW | | | | | | |
| | | | G [9] | DX | Z | None | | | | | | |
| | | | M [0] | DX for HP Operation | | | | | | | | |
| Heating Options | 7 | 11-12 | 12 | 3 Element Low Cap. Electric Heat | 67 | 3 Row HW | | | | | | |
| | | | 13 | 6 Element Low Cap. Electric Heat | 68 | Steam Low Cap. | | | | | | |
| | | | 65 | 1 Row HW | 69 | Steam High Cap. | | | | | | |
| | | | 66 | 2 Row HW | 00 | None | | | | | | |
| Hand Orientation | 8 | 13 | A | Same Hand LH | E | LH Heating / RH Cooling | | | | | | |
| | | | B | Same Hand RH | F | RH Heating / LH Cooling | | | | | | |
| | | | D | RH Electric Heat Only | R | Single Coil Left Hand | | | | | | |
| | | | G | RH Electric Heat / LH Cool | S | Single Coil Right Hand | | | | | | |
| Controls | 9 | 14-15 | ## | MicroTech Controls (see control code table below) | | | | | | | | |
| | | | Control Features | | | | Feature Selections | | | | | |
| | | | Open Protocol | BACnet / Stand-Alone | • | | • | | • | • | | |
| | | | | LONMARK | | • | | • | | | • | • |
| | | | DCV | CO ₂ Sensor | | | • | • | | • | | • |
| | | | Factory-Installed Keypad | LUI | | | | | • | • | • | • |
| | | | | | Control Code | | | | | | | |
| | | | Economizer Control | Basic | B1 | B5 | B9 | BD | BH | BL | BP | BT |
| | | | | Expanded | E1 | E5 | E9 | ED | EH | EL | EP | ET |
| | | | | Leading-Edge | L1 | L5 | L9 | LD | LH | LL | LP | LT |
| 23 | Field Mounted Controls (By Others) | | | | | | | | | | | |
| 17 | Digital Ready | | | | | | | | | | | |

Model Nomenclature (Continued)

| Category | Code Item | Code Option | Code Designation & Description | |
|-------------------------------|-----------|-------------|--------------------------------|---|
| Discharge | 10 | 16-17 | AH | Front Discharge Duct Collar- 36" Length Unit |
| | | | AT | Front Disch. Double Deflection Grille- 36" Length |
| | | | BD | Down Disch. Double Deflection Grille- 40" Length |
| | | | FD | Front Discharge Duct Collar- 40" Length Unit |
| | | | FG | Front Disch. Double Deflection Grille- 40" Length |
| Return Air/Outside Air | 11 | 18-19 | 25 | Recirculation RA Bottom Grille- No RA/OA Dampers |
| | | | 26 | RA Bottom Grille & OA Top Duct Collar |
| | | | 27 | RA Bottom Grille & OA Rear Duct Collar |
| | | | 28 | RA Rear Duct Grille & OA Top Duct Collar |
| | | | 29 | RA Rear Duct Grille & OA Rear Duct Collar |
| Power Connection | 12 | 20 | G | Box With Switch |
| | | | J | Box w/switch, w/USB |
| | | | K | Box w/switch, w/SD |
| | | | M | Box w/switch, w/USB, w/SD |
| Color | 13 | 21 | Y | Off White |
| SKU Type | 14 | 22 | B | Standard Delivery |
| Product Style | 15 | 23 | 1 | 1st Style Change |

Model Types

AHF – Face & Bypass

The model type AHF units include a face and bypass damper. By modulating the damper position a portion of the airflow is bypassed around the heating and/or cooling coil(s). The discharge air temperature is controlled by varying the portion of the airflow going across the active coil. In units with independent heating and cooling coils the heating coil will be positioned before the cooling coil. The exception to this rule is with electric heat, which is always installed after any cooling coil.

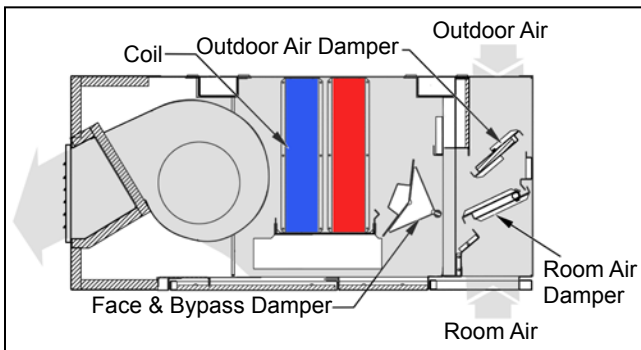

AHB – Face & Bypass, Reheat

The model type AHB units include a face and bypass damper. By modulating the damper position a portion of the airflow is bypassed around the heating and/or cooling coil(s). The discharge air temperature is controlled by varying the portion of the airflow going across the coil. Model AHB units will always have a heating coil positioned after the cooling coil to allow for dehumidification with reheat capability.

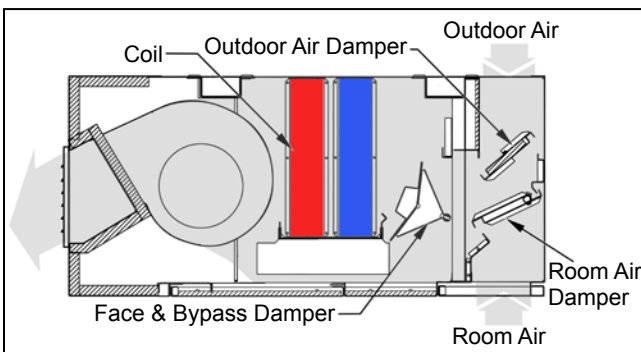

AHV – Valve Control

On model type AHV units the full airflow is directed across the coil(s) at all times. Discharge air temperature is controlled by modulating the heating and/or cooling valve(s). In units with independent heating and cooling coils the heating coil will be positioned before the cooling coil. The exception to this rule is with electric heat, which is always installed after any cooling coil.

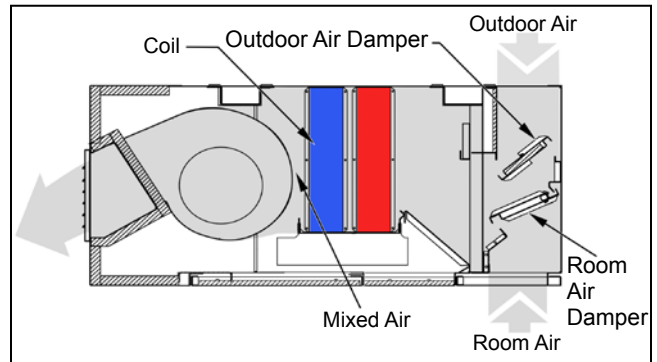

AHR – Valve Control, Reheat

On model type AHR units the full airflow is directed across the coil(s) at all times. Discharge air temperature is controlled by modulating the heating and/or cooling valve(s). Model AHR units will always have a heating coil positioned after the cooling coil to allow for dehumidification with reheat capability. Units with factory installed controls will include a return air humidity sensor.

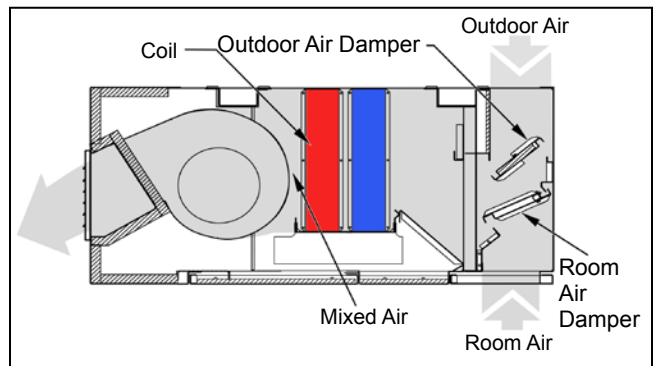

Available Unit Ventilator Combinations

Table 2: Available Unit Ventilator Combinations

| | | Face & Bypass Control | | | Valve Control | | | |
|--|---------------|-----------------------|--------------------|-----------------|---------------------|--------------------|-----------------|-----------------|
| | | Basic F & BP | Electric Heat/Cool | Hydronic Reheat | Basic Valve Control | Electric Heat/Cool | Hydronic Reheat | Electric Reheat |
| | | AHF | AHF | AHB | AHV | AHV | AHR | AHR |
| Air Capacity | Code 4 | | | | | | | |
| 750 CFM | H07, V07 | • | • | • | • | • | • | • |
| 1000 CFM | H10, V10 | • | • | • | • | • | • | • |
| 1250 CFM | H13, V13 | • | • | • | • | • | • | • |
| 1500 CFM | H15, V15 | • | • | • | • | • | • | • |
| 2000 CFM | H20, V20 | • | • | • | • | • | • | • |
| Voltage | Code 5 | | | | | | | |
| 115 - 60 - 1 | A | • | | • | • | | • | |
| 208 - 60 - 1 | C | • | | • | • | | • | |
| 230 - 60 - 1 | G | • | • | • | • | • | • | • |
| 265 - 60 - 1 | J | • | • | • | • | • | • | • |
| 208 - 60 - 3 | D | | • | | | • | | • |
| 230 - 60 - 3 | H | | • | | | • | | • |
| 460 - 60 - 3 | K | | • | | | • | | • |
| Cooling Options | Code 6 | | | | | | | |
| 2 Row CW/HW 2 Pipe | U or 1 | • | | | • | | | |
| 3 Row CW/HW 2 Pipe | D or 2 | • | | | • | | | |
| 4 Row CW/HW 2 Pipe | E or 3 | • | | | • | | | |
| 5 Row CW/HW 2 Pipe | F or 4 | • | | | • | | | |
| 2 Row CW | V or 5 | • | • | • | • | • | • | • |
| 3 Row CW | S or 6 | • | • | • | • | • | • | • |
| 4 Row CW | W or 7 | • | • | • | • | • | • | • |
| 5 Row CW | Y or 8 | • | • | • | • | • | • | • |
| DX | G or 9 | • | | | • | • | • | • |
| DX for Heat Pump Operation | M or 0 | • | | | • | • | • | • |
| None | Z | • | | | • | • | | |
| Heating Options | Code 7 | | | | | | | |
| None | 00 | • | | | • | | | |
| HW One Row | 65 | • | | • | • | | • | |
| HW Two Row | 66 | • | | • | • | | • | |
| HW Three Row | 67 | • | | • | • | | • | |
| Steam Low Capacity | 68 | • | | • | • | | • | |
| Steam High Capacity | 69 | • | | • | • | | • | |
| Low Electric Heat (3 element) | 12 | | • | | | • | | • |
| High Electric Heat (6 element) | 13 | | | | | • | | • |
| Coil Hand Orientation | Code 8 | | | | | | | |
| LH Heating / RH Cool | E | • | | • | • | | • | |
| RH Heating / LH Cool | F | • | | • | • | | • | |
| Single Coil LH | R | • | | | • | | | |
| Single Coil RH | S | • | | | • | | | |
| LH Both Coils (Only With Controls By Others) | A | • | | • | • | | • | |
| RH Both Coils (Only With Controls By Others) | B | • | | • | • | | • | |
| RH Electric Heat / LH Cool | G | | • | | | • | | • |
| RH Electric Heat, One Coil | D | | | | | • | | |

Table 3: Available Unit Ventilator Combinations

| | Code 9 | Face & Bypass Control | | | Valve Control | | | |
|---|-----------------------|-----------------------|--------------------|-----------------|---------------------|--------------------|-----------------|-----------------|
| | | Basic F & BP | Electric Heat/Cool | Hydronic Reheat | Basic Valve Control | Electric Heat/Cool | Hydronic Reheat | Electric Reheat |
| | | AHF | AHF | AHB | AHV | AHV | AHR | AHR |
| Controls | Code 9 | | | | | | | |
| MicroTech | See Note ¹ | • | • | ○ | • | • | • | • |
| Digital Ready ² | 17 | • | • | | • | • | | |
| Field Mounted Controls By Others | 23 | • | • | • | • | • | • | • |
| Air Discharge, Unit Length | Code 10 | | | | | | | |
| Front Discharge Duct Collar- 36" Length Unit (except 2000 cfm unit) | AH | • | • | • | • | • | • | • |
| Front Discharge Double Deflection Grille- 36" Length (except 2000 cfm unit) | AT | • | • | • | • | • | • | • |
| Down Discharge Double Deflection Grille- 40" Length | BD | • | • | • | • | • | • | • |
| Front Discharge Duct Collar- 40" Length Unit (2000 cfm unit only) | FD | • | • | • | • | • | • | • |
| Front Discharge Double Deflection Grille- 40" Length (2000 cfm unit only) | FG | • | • | • | • | • | • | • |
| Return Air/Outside Air Options | Code 11 | | | | | | | |
| Recirculation RA Bottom Grille- No RA/OA Dampers | 25 | • | • | • | • | • | • | • |
| RA Bottom Grille/OA Top Duct Collar | 26 | • | • | • | • | • | • | • |
| RA Bottom Grille/OA Rear Duct Collar | 27 | • | • | • | • | • | • | • |
| RA Rear Duct Collar/OA Top Duct Collar | 28 | • | • | • | • | • | • | • |
| RA Rear Duct Collar/OA Rear Duct Collar | 29 | • | • | • | • | • | • | • |
| Power Connection | Code 12 | | | | | | | |
| Box With Switch | G | • | • | • | • | • | • | • |
| Box w/switch, w/USB | J | • | • | ○ | • | • | • | • |
| Box w/switch, w/SD | K | • | • | ○ | • | • | • | • |
| Box w/switch, w/USB, w/SD | M | • | • | ○ | • | • | • | • |
| Color | Code 13 | | | | | | | |
| Off White | W | • | • | • | • | • | • | • |

The “•” mark indicates the coil combination listed to the left is available.
 The “○” mark indicates the coil combination listed to the left will be added in the future.

¹ See MicroTech Control Availability in "Model Nomenclature" on page 15
² Some coil combinations and configurations may not be available for Digital Ready controls.

Table 4: MicroTech Controls Combinations

| Control Features | | Feature Selections | | | | | | | |
|--------------------------|------------------------|--------------------|----|----|----|----|----|----|----|
| Open Protocol | BACnet / Stand-Alone | • | | • | | • | • | | |
| | LONMARK | | • | | • | | | • | • |
| DCV | CO ₂ Sensor | | | • | • | | • | | • |
| Factory-Installed Keypad | LUI | | | | | • | • | • | • |
| | | Control Code | | | | | | | |
| Economizer Control | Basic | B1 | B5 | B9 | BD | BH | BL | BP | BT |
| | Expanded | E1 | E5 | E9 | ED | EH | EL | EP | ET |
| | Leading-Edge | L1 | L5 | L9 | LD | LH | LL | LP | LT |

Table 5: Available Coil Combinations

| First Position In Airstream | Second Position In Airstream | Face & Bypass Control | | | Valve Control | | | |
|-----------------------------|------------------------------|-----------------------|--------------------|-----------------|---------------------|--------------------|-----------------|-----------------|
| | | Basic F & BP | Electric Heat/Cool | Hydronic Reheat | Basic Valve Control | Electric Heat/Cool | Hydronic Reheat | Electric Reheat |
| | | AHF | AHF | AHB | AHV | AHV | AHR | AHR |
| Heating Only | | | | | | | | |
| 65 66 67 | Z | • | | | • | | | |
| Z | 68 69 | • | | | • | | | |
| Z | 12 13 | | | | | • | | |
| Cooling Only | | | | | | | | |
| V S W Y 5 6 7 8 | 00 | • | | | • | | | |
| G M 9 0 | 00 | | | | • | | | |
| Heat/Cool | | | | | | | | |
| U D E F 1 2 3 4 | 00 | • | | | • | | | |
| 65 | V S W Y G M 5 6 7 8 9 0 | • | | | • | | | |
| 66 | V S W G M 5 6 7 9 0 | • | | | • | | | |
| 67 | V S G M 5 6 9 0 | • | | | • | | | |
| V S G M 5 6 9 0 | 68 69 | • | | | • | | | |
| V S W 5 6 7 | 12 | | • | | | • | | |
| V S W G M 5 6 7 9 0 | 12 13 | | | | | • | | |
| Cool/Reheat | | | | | | | | |
| V S 5 6 | 65 66 67 68 69 | | | • | | | • | |
| W 7 | 65 66 | | | • | | | • | |
| Y 8 | 65 | | | • | | | • | |
| G 9 | 65 66 67 68 69 | | | | | | • | |
| V S W 5 6 7 | 12 13 | | | | | | | • |
| G 9 | 12 13 | | | | | | | • |

- Notes:**
1. Steam and Electric coils are always in the second position.
 2. The "•" mark indicates the coil combination listed to the left is available.

Heating and cooling coil type codes:

Heating Coils:

- 65 = 1 Row Hot Water Coil
- 66 = 2 Row Hot Water Coil
- 67 = 3 Row Hot Water Coil
- 68 = Low Capacity Steam Coil
- 69 = High Capacity Steam Coil
- 12 = Low Electric Heat Coil
- 13 = High Electric Heat Coil
- 00 = None

Cooling Coils:

- U or 1 = 2 Row CW/HW 2-Pipe Coil
- D or 2 = 2 Row CW/HW 2-Pipe Coil
- E or 3 = 4 Row CW/HW 2-Pipe Coil
- F or 4 = 5 Row CW/HW 2-Pipe Coil
- V or 5 = 2 Row CW Coil
- S or 6 = 3 Row CW Coil
- W or 7 = 4 Row CW Coil
- Y or 8 = 5 Row CW Coil
- G or 9 = Direct Expansion Coil
- M or 0 = DX for Heat Pump
- Z = None

Discharge Air Arrangements

For all recessed applications (full or partial) carefully check that the inlet air and the discharge air physical locations are compatible with the specific installation.

Also verify that there is sufficient clearance to open and remove the bottom access panels and end panels for routine maintenance.

Duct collars are shipped loose for field installation by others. All dimensions are approximate.

36" Deep Units (750 to 1500 CFM)

Figure 26: Arrangement AT - Unit-Mounted Plenum with Front Discharge Double-Deflection Grille

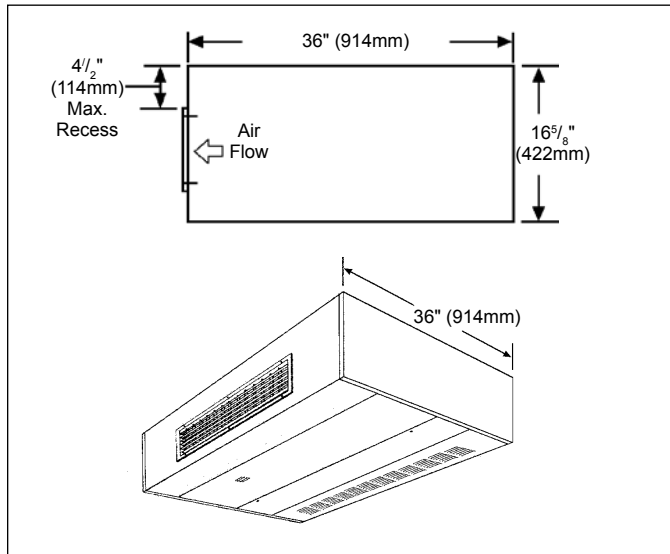
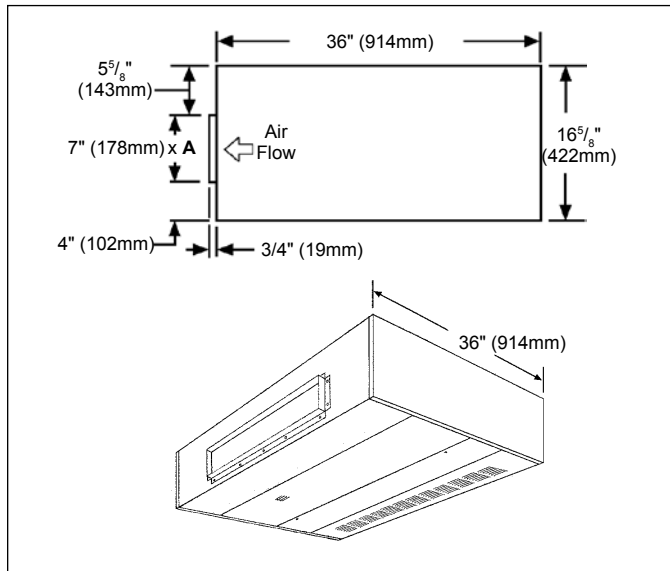

Figure 27: Arrangement AH - Unit-Mounted Plenum with Front Discharge Duct Collar



40" Deep Units (750 to 2000 CFM)

Figure 28: Arrangement BD- Unit-Mounted Plenum with Bottom Discharge Double Deflection Grille

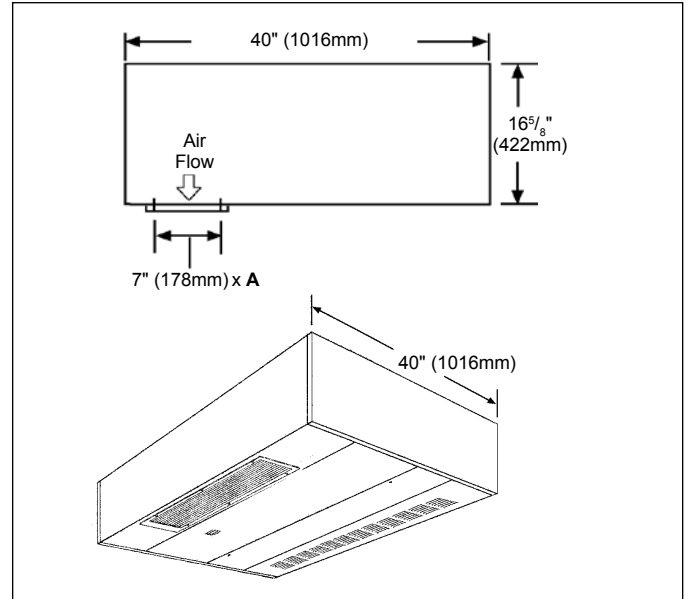

Figure 29: Arrangement FG Unit Mounted Plenum with Front Discharge Double Deflection Grille

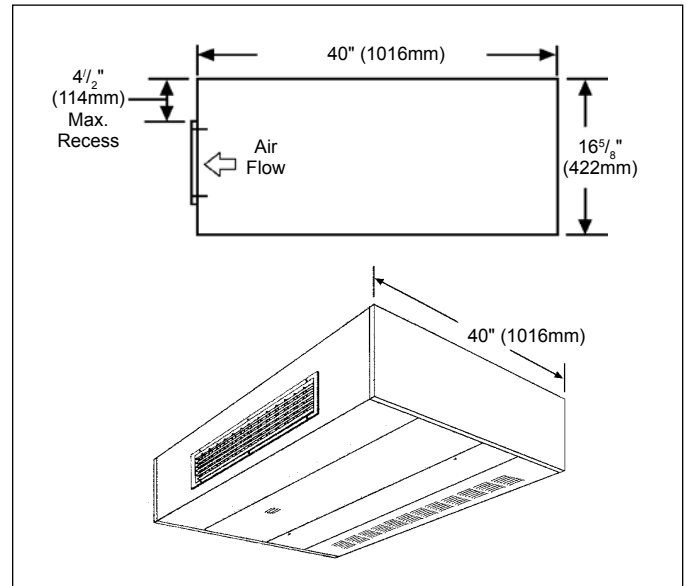
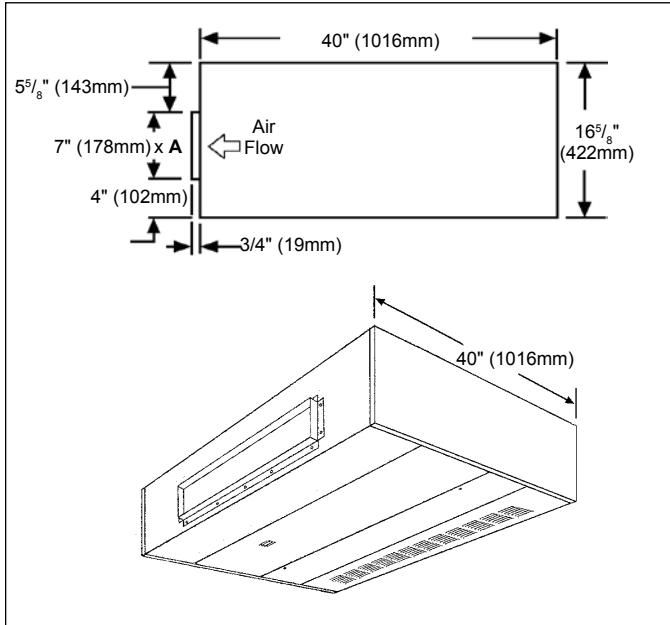

Table 6: Duct dimensions "A" for all units

| Unit Size | | 07 | 10 | 12 | 15 | 20 |
|-----------|----|-----|------|------|------|------|
| A | in | 35 | 48 | 60 | 72 | 72 |
| | mm | 914 | 1219 | 1524 | 1829 | 1829 |

Figure 30: Arrangement FD Front Discharge with Duct Collar (2000 cfm only)



Intake Air Arrangements

Figure 31: Horizontal Room Air (Lower) Intake Knockouts, Horizontal Outdoor Air (Upper) Intake Knockouts and Vertical Outdoor Air Intake Opening With Cover Plate

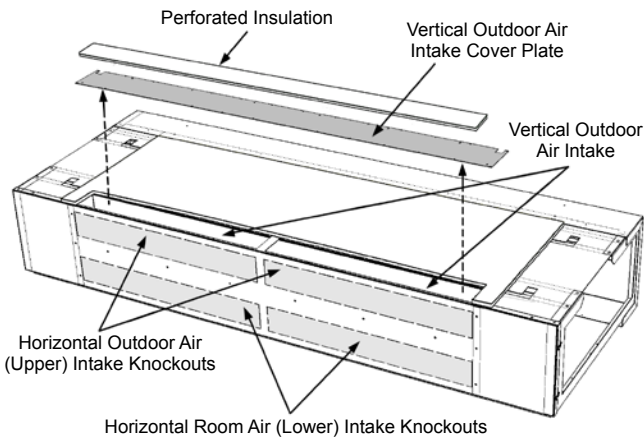

For all recessed applications (full or partial) it is necessary to carefully examine both the inlet air and the discharge air physical locations. This must be done for each location individually and in combination with each other to ensure they are compatible with the specific installation. Duct collars are shipped loose for field installation (by others). It is important also to verify there is sufficient clearance to open and remove the bottom access panels and end panels for routine maintenance. The horizontal room air (lower) intake and horizontal outdoor air (upper) intake knockouts are factory provided and must be removed by the installing contractor based on job specifications. The vertical outdoor air (top) intake cover plate is factory provided and must be removed by the installing contractor when top outdoor air ventilation intake is specified.

Figure 32: Arrangement 25 Recirculating Room Air (No Room Air/Outside Air Dampers)

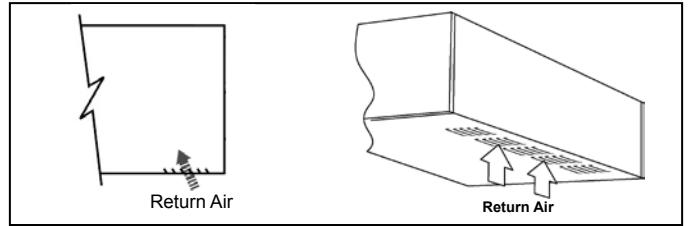

Figure 33: Arrangement 26 Return Air Bottom Grille/ Outdoor Air Top Duct Collar

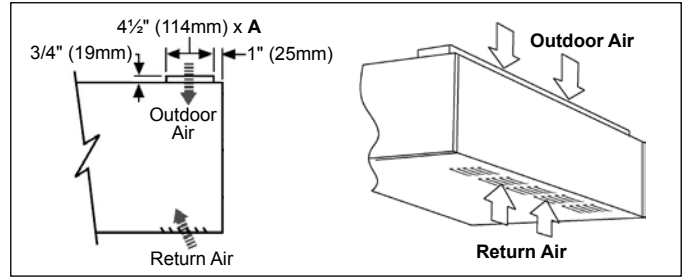

Figure 34: Arrangement 27 Return Air Bottom Grille/ Outdoor Air Rear Duct Collar

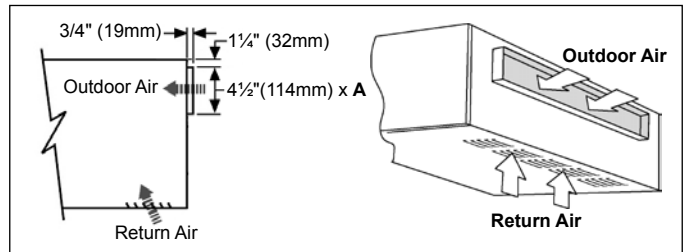

Figure 35: Arrangement 28 Return Air Rear Duct Collar/ Outdoor Air Top Duct Collar

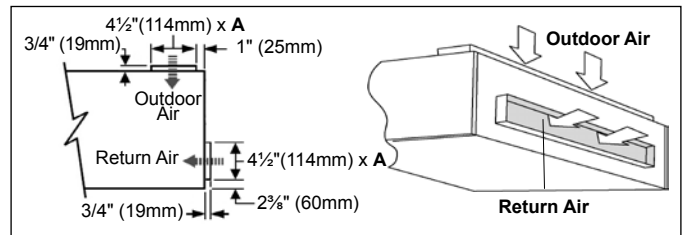

Figure 36: Arrangement 29 Return Air Rear Duct Collar/ Outdoor Air Rear Duct Collar

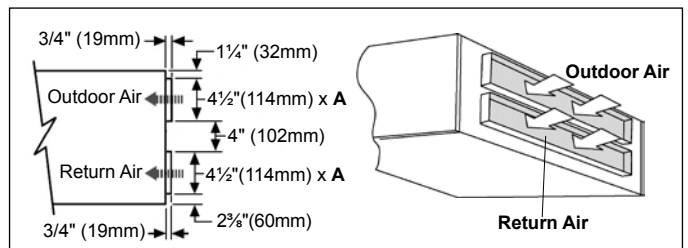
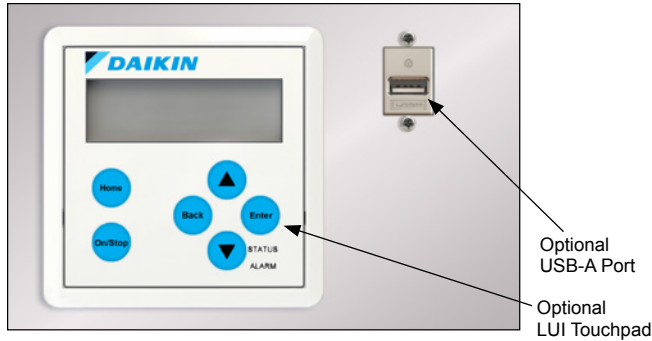

Table 7: Duct dimensions "A" for all units

| Unit Size | | 07 | 10 | 12 | 15 | 20 |
|-----------|----|-----|------|------|------|------|
| A | in | 35 | 48 | 60 | 72 | 72 |
| | mm | 914 | 1219 | 1524 | 1829 | 1829 |

MicroTech® Controls (Optional)



Daikin unit ventilators equipped with MicroTech unit controllers can provide superior performance and easy integration into your building automation system of choice. MicroTech benefits include:

- Factory integrated and tested controller, sensor, actuator and unit options promote quick, reliable start-up and minimize costly field commissioning.
- High-performance features and advanced control options can quickly pay for themselves in saved energy costs and more comfortable classrooms.
- Select from three control levels: stand-alone, server-client or network control.
- For network control applications, our Protocol Selectability feature provides easy, low-cost integration of Daikin unit ventilators into most building automation systems.
- Flexible BAS network communication options guard against controls obsolescence, keeping MicroTech controls viable for the life of your Daikin equipment.

Three Control Levels

MicroTech unit controllers provide the flexibility to operate Daikin unit ventilators on any of three levels:

- As stand-alone units, with control either at the unit or from a wall sensor.
- In a server-client relationship, where server units follow the client unit for some or all functions.
- Controlled as part of a network using a centralized building automation system.

Stand-Alone Control

When operating in stand-alone mode, the MicroTech controller performs complete room temperature and ventilation control. Units can be operated in occupied, unoccupied, stand-by, or bypass (tenant override) modes. Occupied/unoccupied changeover can be accomplished:

- Automatically by an internal Daily Schedule (two occupied times and two unoccupied times for each of the seven days, and one holiday schedule)
- Using a field-wired occupancy sensor.

If a school has more than one zone, separate, internally-programmed schedules are used to regulate each zone.

Server-Client Control

Designate the client and server units and we will factory configure and install the controllers so they are set up for a local peer-to-peer network between units (leaving only the network wiring between these units to be field installed).

Client units can be field-configured to be dependent or independent as follows:

- Dependent client units follow the server unit completely. They are ideal for large spaces that have even loads across the space (such as some libraries).
- Independent client units (default) use server setpoints and client sensors. The client follows the server unit modes, such as heat or cool, but has the flexibility to provide the conditioning required for its area within the space. Independent client units perform better in spaces where loads vary from one area of the space to the other (such as stairwells or cafeterias).

Network Control

MicroTech unit controllers provide easy integration into your building automation system of choice. All factory-installed options are handled by the unit controller. This simplifies the transmission of monitoring and setpoint data to the building automation system.

MICROTECH controls have on-board BACnet communication with optional LONTALK, to communicate control and monitoring information to your BAS, without the need for costly gateways. Unit controllers are LONMARK certified with the optional LONWORKS® communication module.

Flexible network communication options via our Protocol Selectability feature help you avoid control obsolescence over the life of your Daikin equipment.

USB Interface

An optional USB-A port can be factory-configured. This option simplifies field access to the MicroTech controller. The USB interface can be used for downloading code, changing unit configuration, accessing external memory, or a field-connection to run the service tool. Technicians will have access to read all inputs, download code, setup/download trend data, and backup, restore, or change unit configuration.

SD Card

An optional SD card can be factory configured. The SD card allows storage of data trending and configuration parameters. For further details see [page 77](#).

Note: A 6ft USB-A to USB-A cable can be purchased as an accessory, part number 910295895

Digital Ready Systems

For unit ventilator applications where controls are to be supplied by others, specifying a Digital Ready system can greatly simplify control installation.

Digital Ready systems come with a factory-installed, pre-wired package of selected Direct Digital Control (DDC) components. This greatly facilitates the field hook up of a DDC unit ventilator controller that is compatible with these components and that is capable of providing the standard ASHRAE II cycle.

Figure 37: Three 10-pole Europa Type 16 AWG Terminal Strips

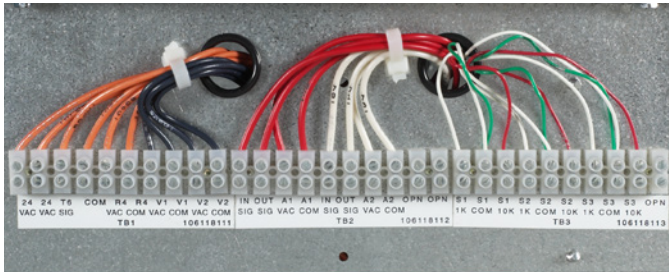

Note: It is the responsibility of the control supplier to ensure the controls operate correctly and protect the unit.

Digital Ready systems include a non-fused power interrupt switch, a control power transformer, three-speed fan switch, damper actuator(s), sensors and other protection devices. The sensors and actuators are factory wired to a common terminal strip in the control compartment. For a detailed list of components see "Digital Ready Systems" on page 88.

Field Mounted Controls (By Others)

There are many advantages to having the basic temperature controls in Daikin units be MicroTech and factory-installed in the unit ventilator prior to shipment. However, factory installation of controls cannot always be achieved. In such cases, we will ship the unit without any temperature controls. It is the responsibility of the automatic temperature control supplier to provide a control package specifically for installation in the Daikin unit ventilator.

On units with the Field Mounted Controls option the unit will include a non-fused power interrupt switch and three-speed fan switch. Units with DX cooling, hot water or chilled water coils will also have a low limit thermostat.

Economizer Modes

Economizer operation is facilitated by the outdoor air damper, which automatically adjusts the above-minimum outside air position to provide free cooling when the outdoor air temperature is appropriate. Three levels of economizer control are available:

Basic Economizer Operation: The MicroTech controller compares the inside and outside temperatures. If the temperature comparison is satisfactory, then free-air economizer operation is used to cool the space. Reheat units also come configured with an indoor humidity sensor.

Expanded Economizer Operation: In addition to comparing inside and outside temperatures, outdoor relative humidity is measured to calculate outside air enthalpy. If the enthalpy set point is not exceeded, and the temperature comparison is satisfactory, then free economizer operation is used to cool the space. This helps to minimize the entrance of humid outside air.

Leading-Edge Economizer Operation: The MicroTech controller compares both indoor and outdoor temperatures and indoor and outdoor relative humidities. Then it calculates both inside and outside air enthalpy to determine if free economizer operation can cool the space with non-humid outside air. This is a true enthalpy economizer—a first for unit ventilators.

Demand Control Ventilation

The optional unit mounted, single beam absorption infrared gas sensor has a sensing range of 0 – 2000 ppm and voltage output of 0 to 10 VDC (100 ohm output impedance). The pitot tube sensing device is located in the unit ventilator's return air stream. The optional CO₂ sensor is used with the UVC's Demand Control Ventilation feature to vary the amount of outside air based on actual room occupancy. With network applications, the unit mounted sensor can be overridden by a remote sensor through the network.

Figure 38: Optional CO₂ Sensor



Wall Louvers & Grilles

Daikin wall louvers allow outdoor air to be drawn in while blending with the building architecture. They are sized to match the unit outside air opening and provide maximum air intake. Heavy-gauge, all-aluminum construction is standard, with a decorative grille optional.

Both louvers and grilles are available either painted or unpainted. When painted, a specially formulated, environmentally friendly thermosetting urethane powder is applied electrostatically and baked for long lasting beauty as well as resistance to corrosion. The paint is then oven cured to provide correct chemical cross-linking, which can provide years of service. The extruded 6063-T5 aluminum used for louvers and grilles is suitable for color anodizing by others.

Figure 39: Intake Louvers

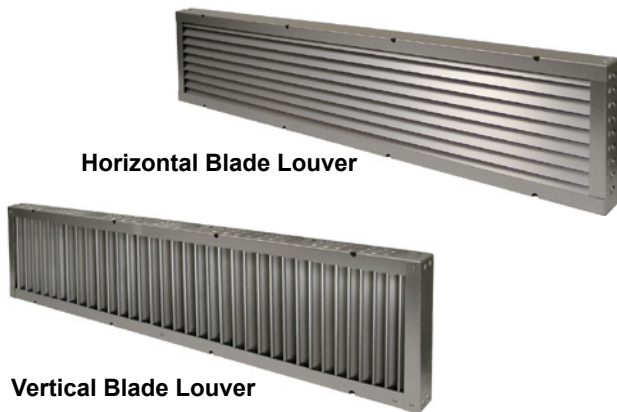

Horizontal Blade Louver

Vertical Blade Louver

Louver Details

Louvers are available in both horizontal and vertical blade configurations (Figure 39 on page 25):

- **Horizontal blade construction** turns the incoming air to keep moisture from entering. Bottom weep holes drain moisture to the outside.
- **Vertical-blade construction** provides positive water impingement and entrapment. The bottom lip drains moisture to the outside.

Louvers can be supplied with or without flanges

- **Flanged louvers** are typically used for a panel wall finish (Figure 40).
- **Unflanged louvers** are typically used for recessing into a masonry wall.

Figure 40: Flanged Louver (Indoor View)

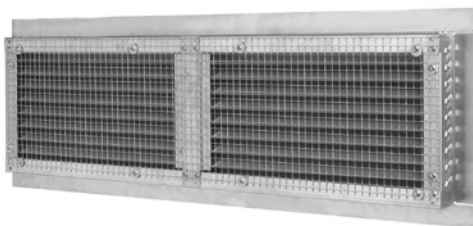

A diamond pattern mesh bird screen (Figure 41) located on the leaving air side of the louver prevents birds and other small animals from entering. The screen's strong aluminum mesh is designed to minimize air pressure drops, unlike expanded metal mesh.

Figure 41: Louver Assembly with Grille

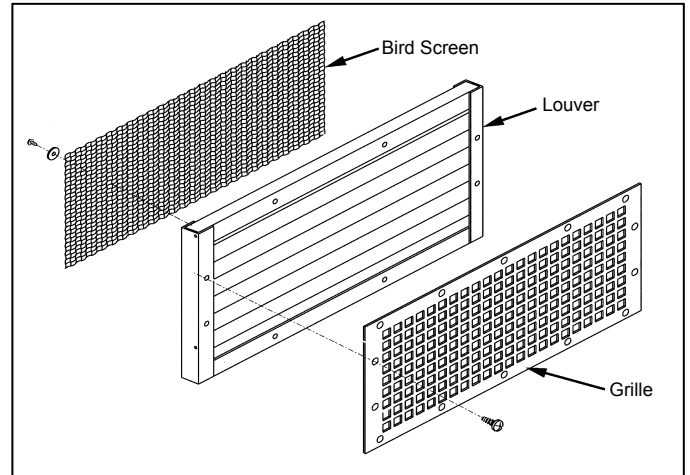

Grille Details

Daikin decorative intake grilles constructed of heavy-gauge 6063-T5 extruded aluminum are available painted or unpainted with holes for mounting to building exteriors (Figure 42). Their square holes are designed to match the blades of the Daikin louver, maximizing the air opening. See Figure 44 on page 26

Figure 42: Decorative Intake Grille

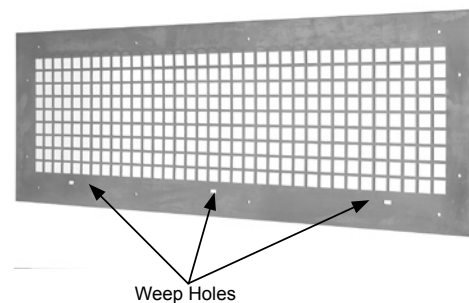

Figure 43: Horizontal Louver with Decorative Intake Grille

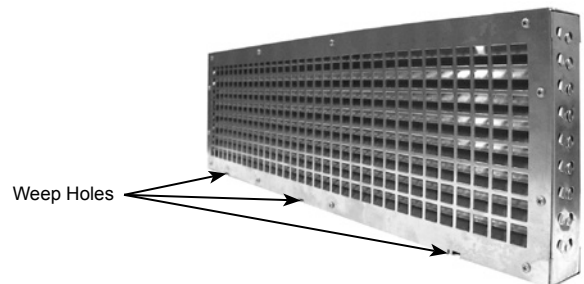
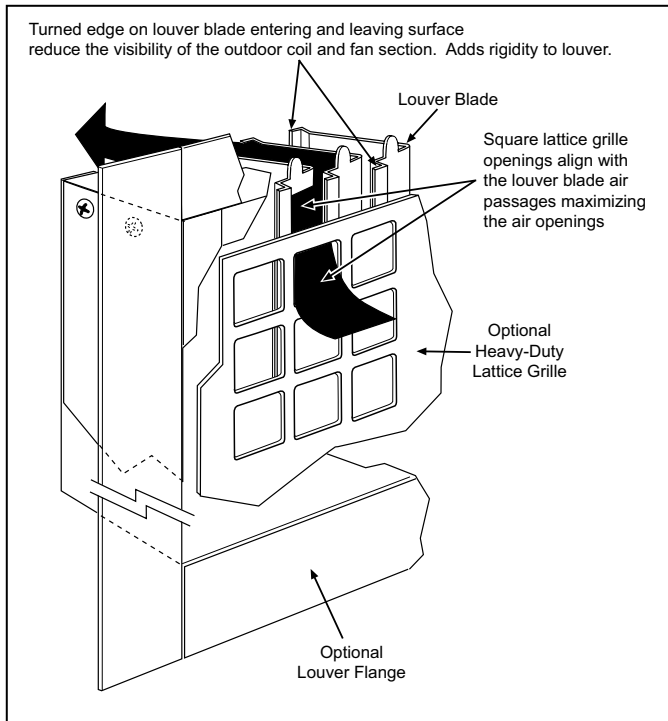

Figure 44: Vertical Louver with Decorative Intake Grille Detail



VentiMatic™ Shutter – Room Exhaust Ventilation

Outdoor air introduced by the unit ventilator must leave the room in some way. In some states, exhaust vents are required by law or code to accomplish this. The VentiMatic shutter is a more economical solution to the problem.

The VentiMatic shutter is a continuously variable, gravity-actuated room exhaust vent (Figure 45). It operates in direct response to positive static air pressure created when ventilation air is brought into the room by the unit ventilator. It is a “one-way” shutter that opposes any flow of air into the room.

Figure 45: VentiMatic Shutter



The VentiMatic Shutter’s ability to exhaust only the amount of air required results in considerable energy savings. In the heating mode, the unit ventilator will be able to bring in only the required percent minimum outdoor air. Unlike systems that rely on powered exhaust, no energy will be wasted heating excess outdoor air. In the cooling mode, the unit ventilator will be able to bring in 100% outdoor air for full natural or free cooling when it is energy effective.

Since it is not powered, VentiMatic Shutter’s operation is inherently silent. Unlike other non-powered vents, it opens at an extremely low positive pressure (0.005"). Its shutter flaps are made of temperature-resistant glass fabric impregnated with silicone rubber for flexibility and long life. This fabric retains its original properties down to -50°F.

Physical Data

Table 8: AH General Data

| | | H07 | V07 | H10 | V10 | H13 | V13 | H15 | V15 | H20 | V20 | | |
|--|--------------------------------|--|--|--|---|---|--------------------|---------------------|------------|------------|-------------|------------|--|
| Fan Data | Nominal CFM ¹ (L/s) | High Speed | 750 (354) | – | 1000 (472) | – | 1250 (590) | – | 1500 (708) | – | 2000 (944) | – | |
| | | Max. Speed | – | 750 (354) | – | 1000 (472) | – | 1250 (590) | – | 1500 (708) | – | 2000 (944) | |
| | | Med. Speed | 675 (319) | – | 900 (425) | – | 1100 (519) | – | 1350 (637) | – | 1800 (850) | – | |
| | | Min. Speed | – | 375 (177) | – | 500 (236) | – | 625 (295) | – | 750 (354) | – | 1000 (472) | |
| | | Low Speed | 600 (283) | – | 800 (378) | – | 1000 (472) | – | 1200 (566) | – | 1600 (755) | – | |
| | Number of Fans: | | 2 | | 3 | | 4 | | | | | | |
| | Size | Diameter - in. (mm) | 8.12 (206mm) | | | | | | | | 9.50(241mm) | | |
| | | Width - in. (mm) | 8.25 (210mm) | | | | | | | | 6.00(152mm) | | |
| | Motor | Horsepower | 1/3 | | | | | 3/4 | | | | | |
| | Filter Data | Nominal Size | in. (mm) | 10 x 36-1/2 x 1 | 10 x 48-1/2 x 1 | 10 x 60-1/2 x 1 | 10 x 36-1/2 x 1 | (2) 10 x 36-1/2 x 1 | | | | | |
| 254 x 927 x 25 | | | | 254 x 1232 x 25 | 254 x 1537 x 25 | 254 x 927 x 25 | (2) 254 x 927 x 25 | | | | | | |
| Area - Ft ² (m ²) | | 2.54 (.24) | 3.37 (.31) | 4.2 (.39) | 5.08 (.47) | 5.08(.47) | | | | | | | |
| Quantity | | 1 | | | | | 2 | | | | | | |
| Shipping Weight | 36" Deep Units - lb. (kg) | 350 (168) | 425 (193) | 495 (225) | 570 (259) | na | | | | | | | |
| | 40" Deep Units - lb. (kg) | 370 (163) | 445 (202) | 525 (238) | 600 (272) | 680 (308) | | | | | | | |
| Shipping Size (Carton & Pallet) in. (mm) | | 67L x 23W x 46.75H (1702 x 584 x 1187) | 79L x 23W x 46.75H (2007 x 584 x 1187) | 91L x 23W x 46.75H (2311 x 584 x 1187) | 103L x 23W x 46.75H (2616 x 584 x 1187) | 103L x 23W x 46.75H (2616 x 584 x 1187) | | | | | | | |
| Coil Water Volume Gallons (Liters) | 1 Row Coil | 0.25 (0.95) | 0.31 (1.17) | 0.38 (1.44) | 0.44 (1.67) | 0.44 (1.67) | | | | | | | |
| | 2 Row Coil | 0.45 (1.70) | 0.57 (2.16) | 0.69 (2.61) | 0.82 (3.10) | 0.82 (3.10) | | | | | | | |
| | 3 Row Coil | 0.64 (2.42) | 0.82 (3.10) | 1.01 (3.82) | 1.19 (4.50) | 1.19 (4.50) | | | | | | | |
| | 4 Row Coil | 0.83 (3.14) | 1.08 (4.09) | 1.32 (5.00) | 1.57 (5.94) | 1.57 (5.94) | | | | | | | |
| | 5 Row Coil | 1.03 (3.90) | 1.34 (5.07) | 1.64 (6.21) | 1.95 (7.38) | 1.95 (7.38) | | | | | | | |

¹ Nominal airflow based on 3-row coil configuration

Arrangement AT: 36" Deep Unit Front Discharge with Double-Deflection Grille

Note: Dimensions are approximate. Unit left or right hand determined by viewing unit facing discharge air.

Figure 46: Arrangement AT Front Discharge with Double Deflection Grille

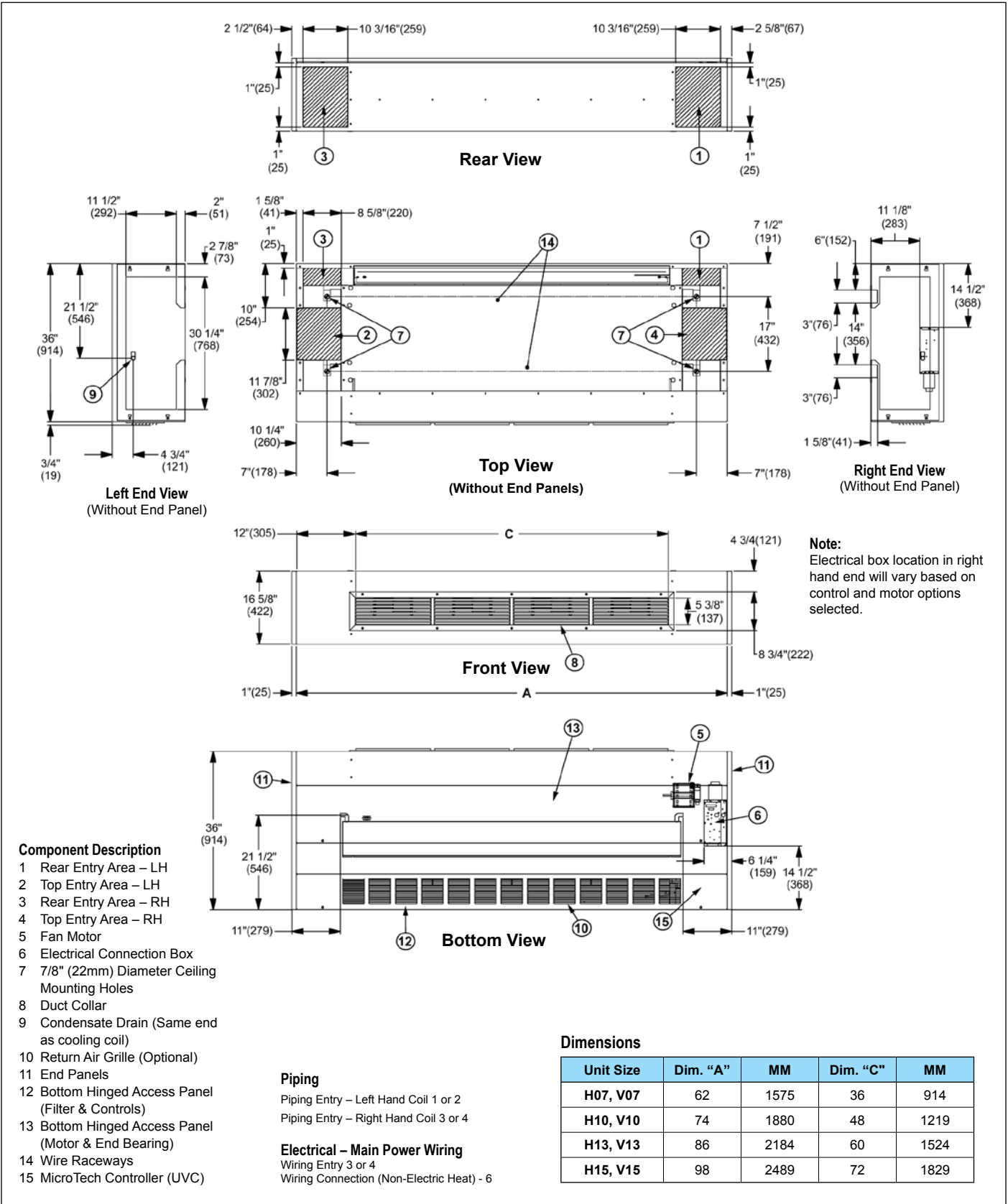

Arrangement AH: 36" Deep Unit Front Discharge with Duct Collar

Note: Dimensions are approximate. Unit left or right hand determined by viewing unit facing discharge air.

Figure 47: Arrangement AH Front Discharge with Duct Collar

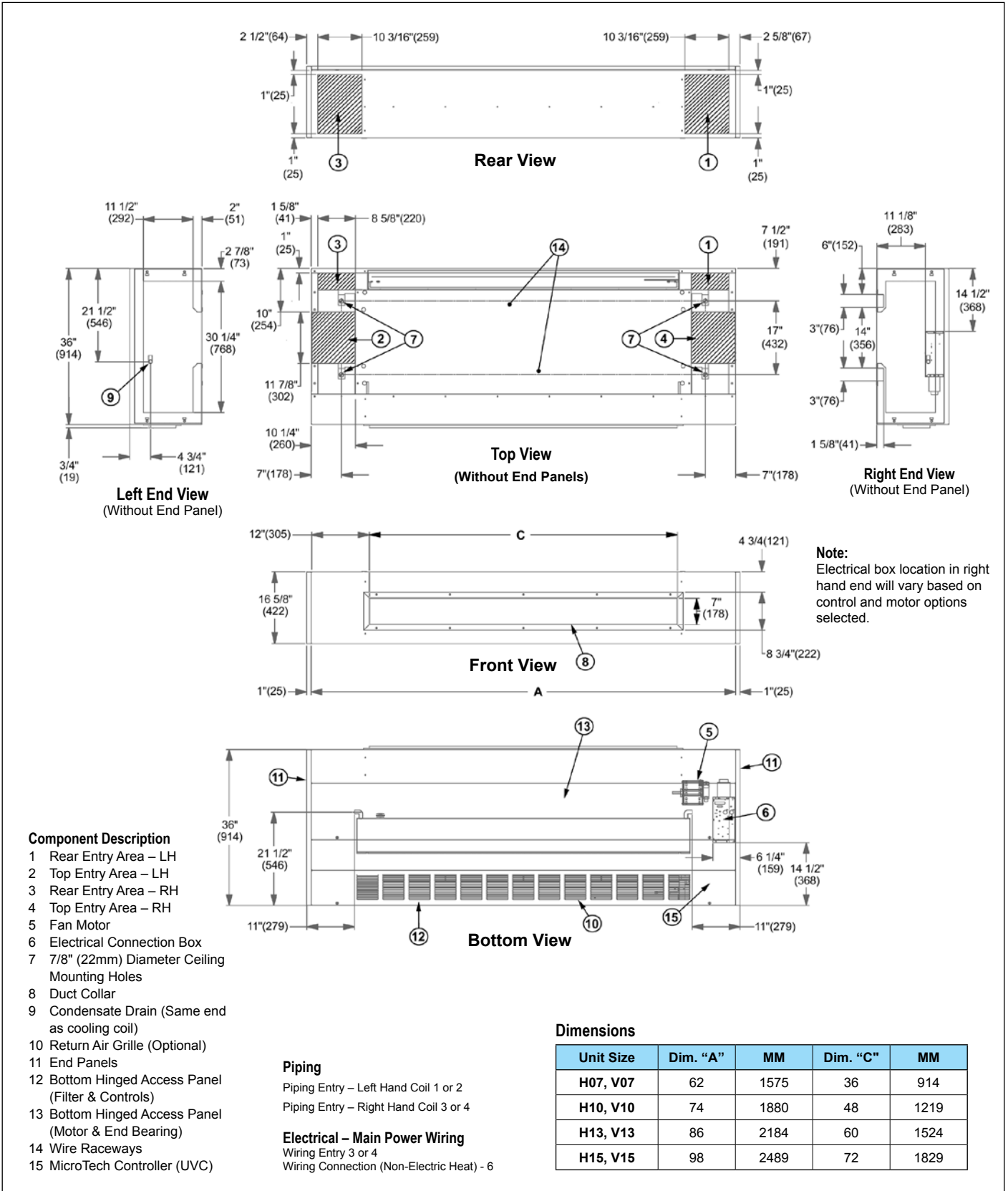

Arrangement BD: 40" Deep Unit Bottom Discharge with Double-Deflection Grille

Note: Dimensions are approximate. Unit left or right hand determined by viewing unit facing discharge air.

Figure 48: Arrangement BD Bottom Discharge with Double Deflection Grille

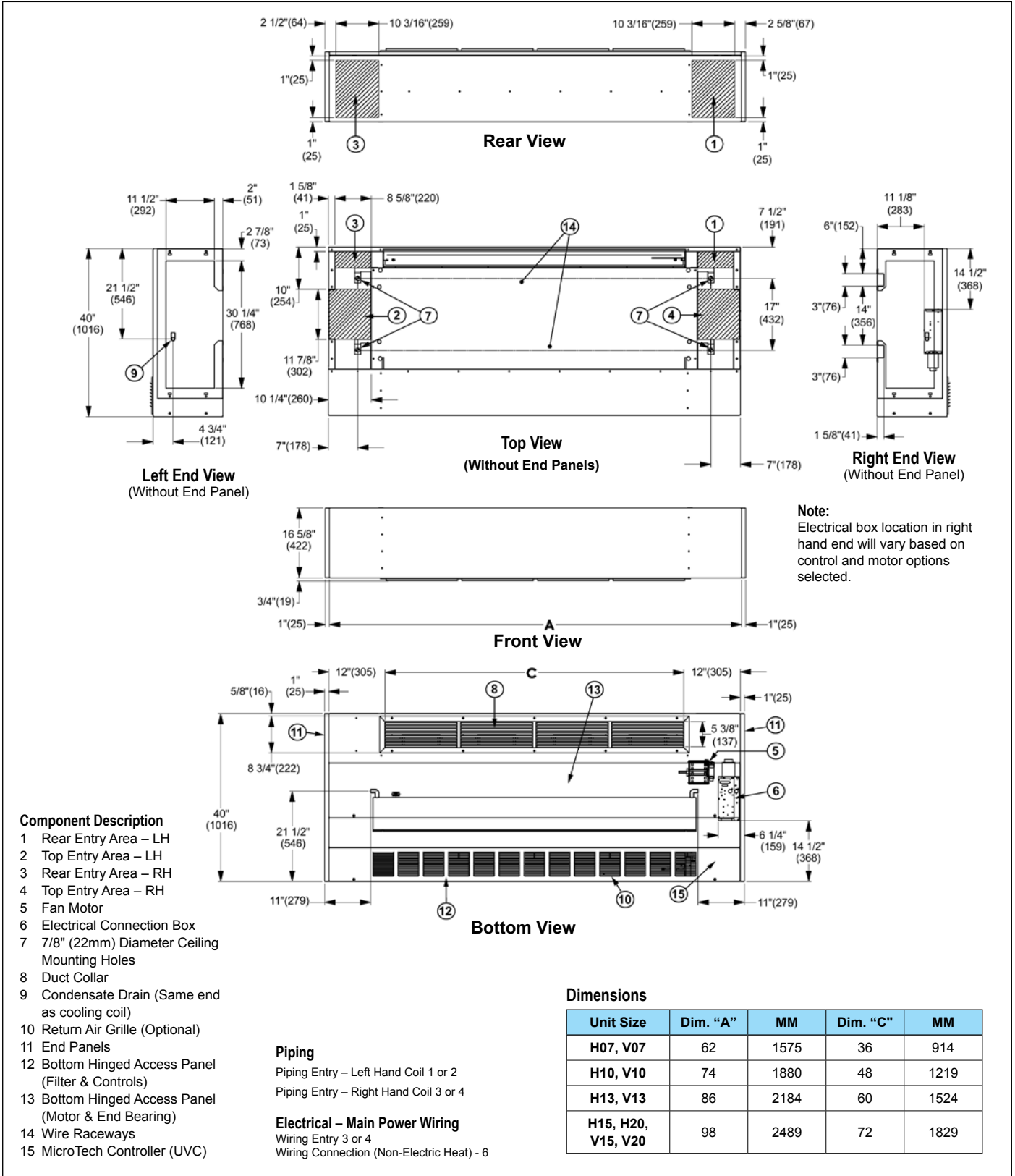

Arrangement FD: 40" Deep Unit Front Discharge, Double Deflection Grille (2000 cfm only)

Note: Dimensions are approximate. Unit left or right hand determined by viewing unit facing discharge air.

Figure 49: Arrangement FG: 40" Deep Unit Front Discharge with Double-Deflection Grille

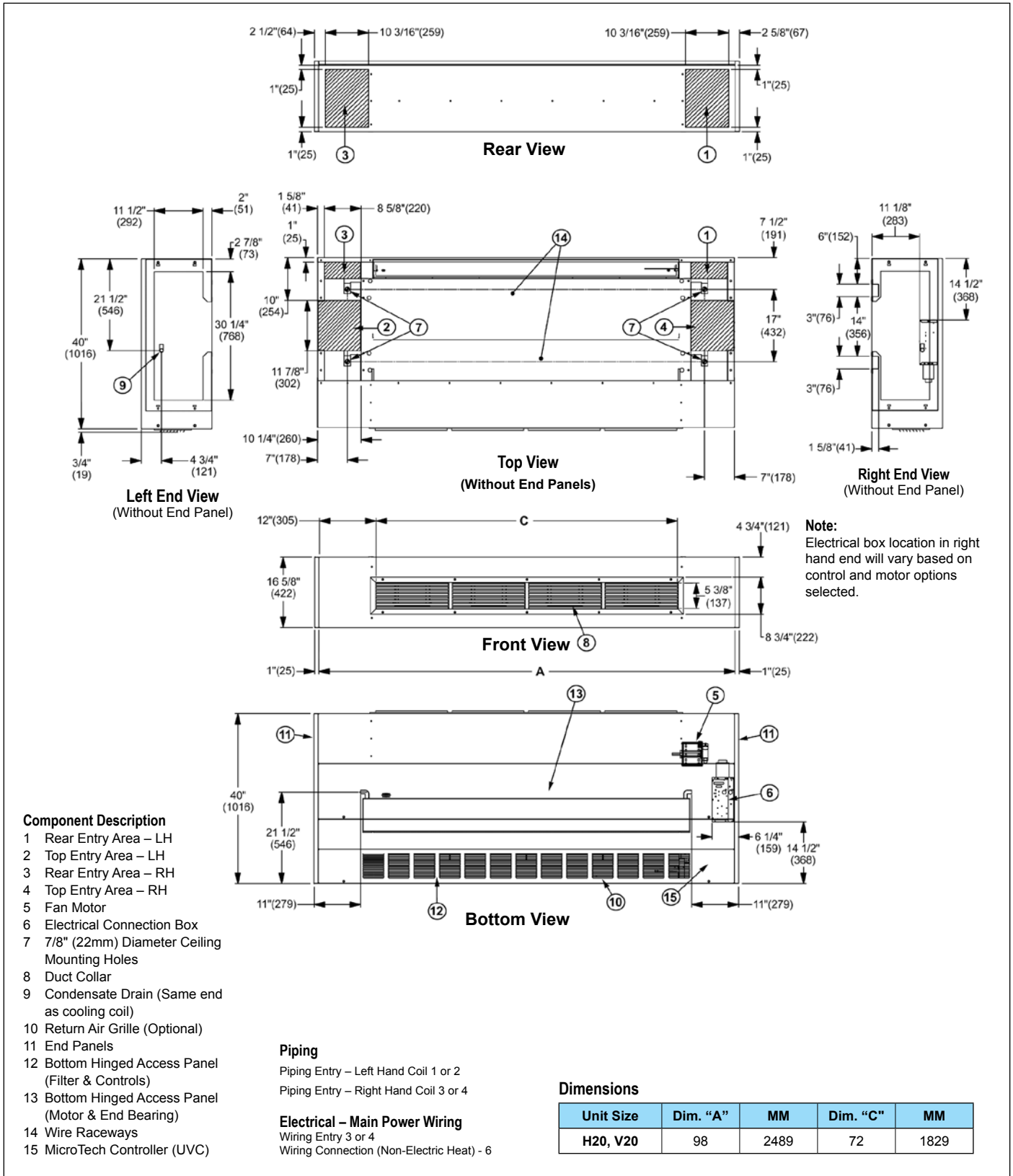

Arrangement FD: 40" Deep Unit Front Discharge with Duct Collar (2000 cfm only)

Note: Dimensions are approximate. Unit left or right hand determined by viewing unit facing discharge air.

Figure 50: Arrangement FD Front Discharge with Duct Collar

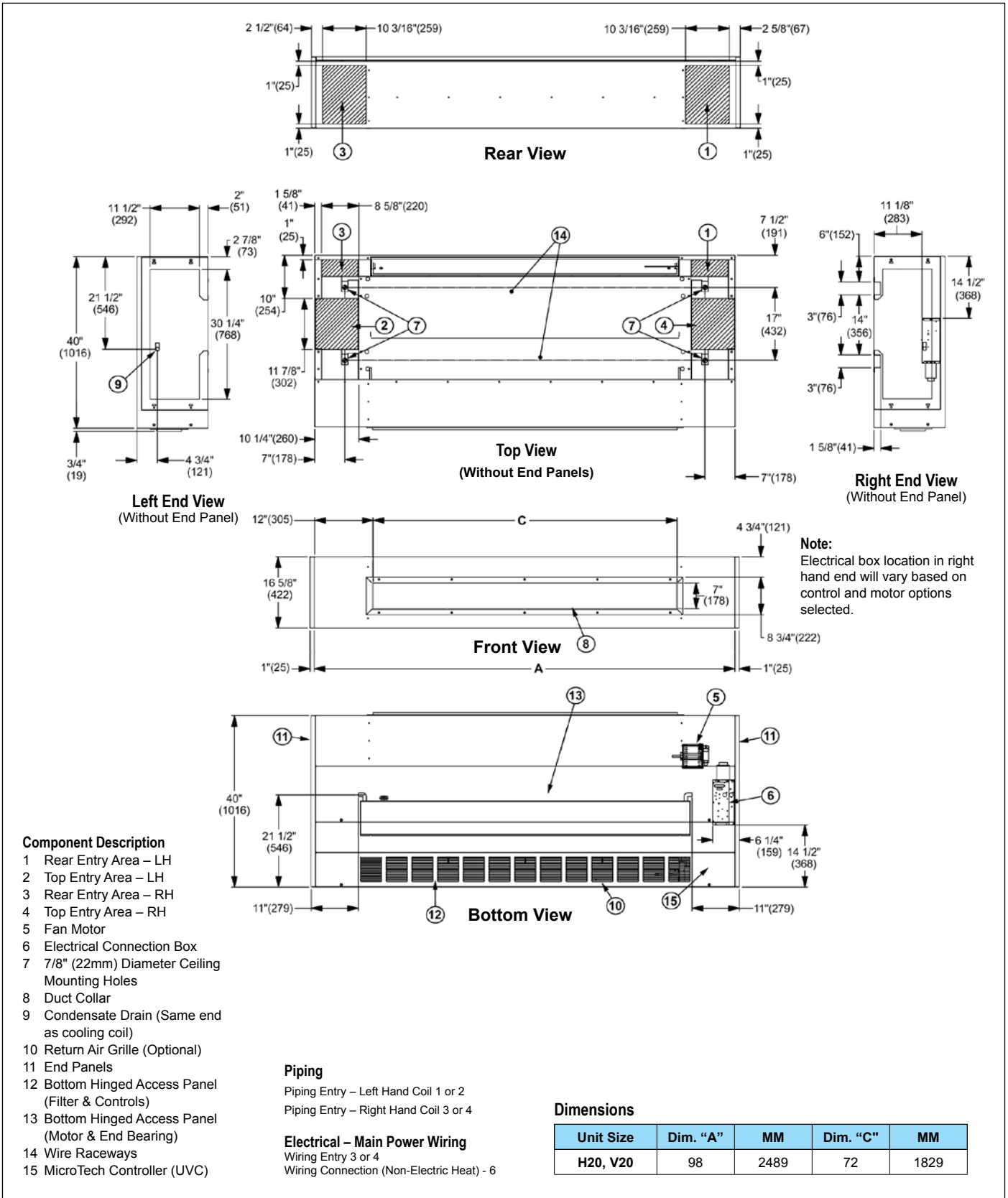

Coil Connections

The dimensional drawings in this section show the location of coil connections for all coil configurations. The drawings are broken into sections as follows:

- “Heat/Cool Units” beginning on [page 34](#)
- “Reheat Units” beginning on [page 36](#)
- “Heating Only Units” on [page 38](#)
- “Cooling Only Units” on [page 39](#)

The following notes apply to all units:

1. All coils have same-end supply and return connections.
2. Steam coils have a factory-installed pressure equalizing valve and a 24" (610mm) long pressure equalizing line which terminates in a 1/2" M.P.T. fitting.
3. Steam/hot water connections may be on the same end as cooling coil connections, but are recommended to be on the opposite end to facilitate piping. (Must be opposite end when using MicroTech controls.)
4. Cooling condensate drain pan is shipped in the level position, with the ability to field adjust the slope front-to-back and left-to-right for full condensate draining.

5. Electric heating coil power connections are right end only. Junction box has 1" (25mm) and 2" (51mm) (trade size) knockouts, 10-1/2" (267mm) from right end of the unit.
6. For limitations with coil combinations see "[Available Coil Combinations](#)" on [page 20](#).
7. Coil connections are 7/8" I.D. (female) and terminate 9" (229mm) from the end of the unit.
8. Steam coils are 1-1/8" female (sweat) connections and terminate 9" (229mm) from the end of the unit.
9. DX coils (G) have O.D. sweat connections. Interconnecting tube is supplied by others. See [Table 9: DX Coil \(G\) Connection Tubing](#) below for correct tubing size.
10. All dimensions are approximate.
11. Abbreviations used in drawing are as follows:
R = Return **S** = Supply
LL = Liquid Line **SL** = Suction Line
EH = Electric Heat

Table 9: DX Coil (G) Connection Tubing

| Unit Series | H07, V07 | | H10, V10 | | H13, V13 | | H15, V15 | | H20, V20 | |
|-------------------------|----------|------|----------|----|----------|----|----------|----|----------|----|
| | in | mm | in | mm | in | mm | in | mm | in | mm |
| Suction Line OD: | 3/4 | 19 | 3/4 | 19 | 7/8 | 22 | 7/8 | 22 | 7/8 | 22 |
| Liquid Line OD: | 1/4 | 6.35 | 1/4 | 6 | 3/8 | 10 | 3/8 | 10 | 3/8 | 10 |

Heat/Cool Units (Right Hand)

- Notes:** 1. Linear dimensions referenced from rear of unit.
 Right hand views shown, dimensions are identical for left-hand configurations. Connection hand is determined by facing discharge air grille.
 2. Numerical codes [#] denote optional stainless steel drain pan (cooling coils).

Figure 51: Chilled/Hot Water (2-pipe) Unit (Coils U[1], D[2], E[3], F[4])

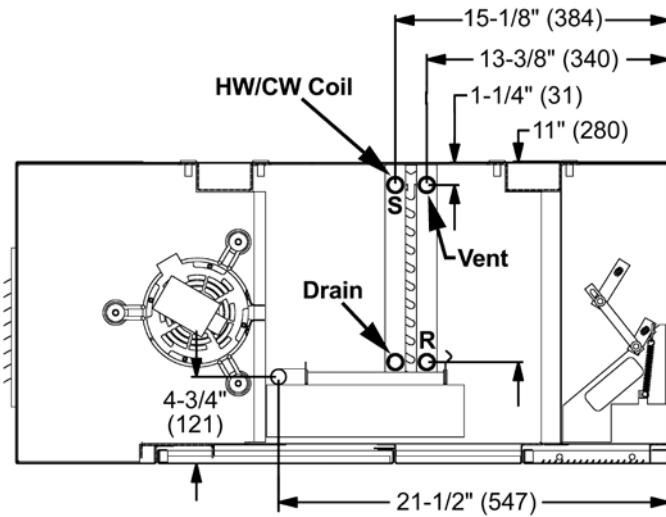

Figure 52: Chilled and Hot Water Unit (Cooling Coils V[5], S[6], W[7] Y[8]; Heating Coils 65, 66, 67)

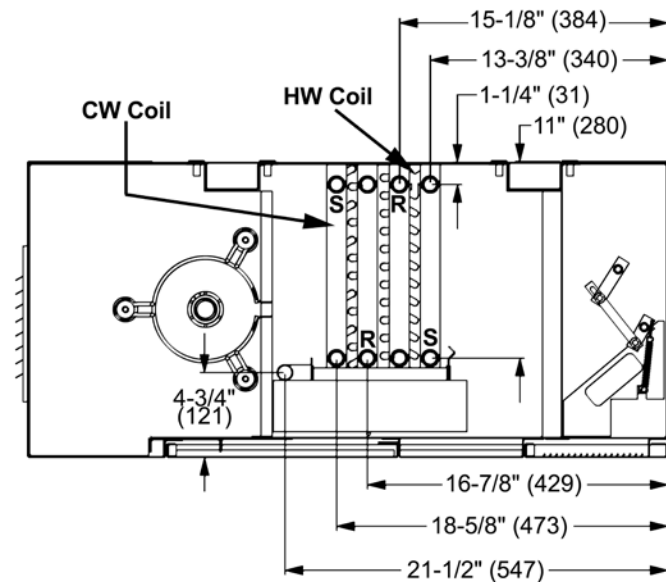

Figure 53: Chilled Water & Steam Unit (Cooling Coils V[5], S[6]; Heating Coils 68, 69)

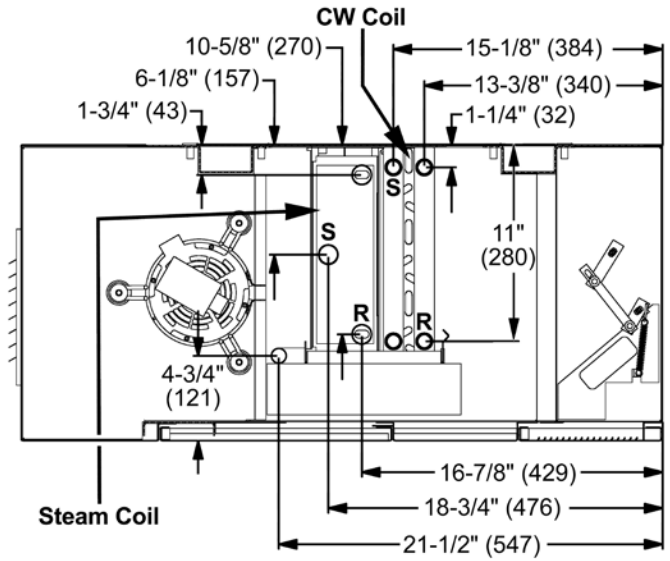

Figure 54: Chilled Water (1st Position) & Electric Heating (Cooling Coils V[5], S[6], W[7]; Heating Coil 12, 13)

Note: Electric heat, right hand only. Chilled water left hand only

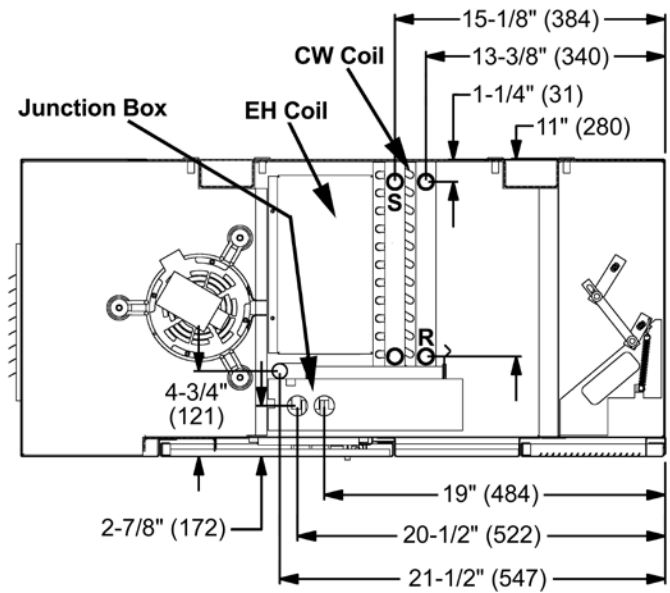

Figure 55: Direct Expansion and Hot Water Unit (Cooling Coil G[9], M[0], Heating Coils 65, 66, 67)

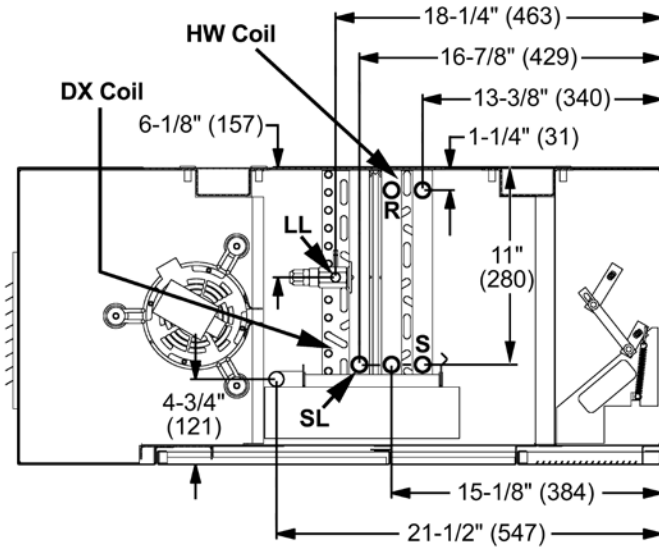

Figure 57: Direct Expansion (1st Position) and Electric Heating (Cooling Coil G[9], M[0], Heating Coil 12, 13)

Note: Electric heat, right hand only. Direct expansion (DX) left hand only

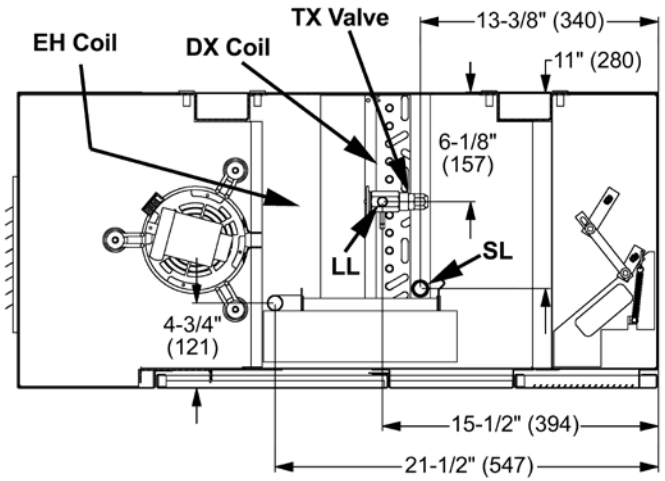
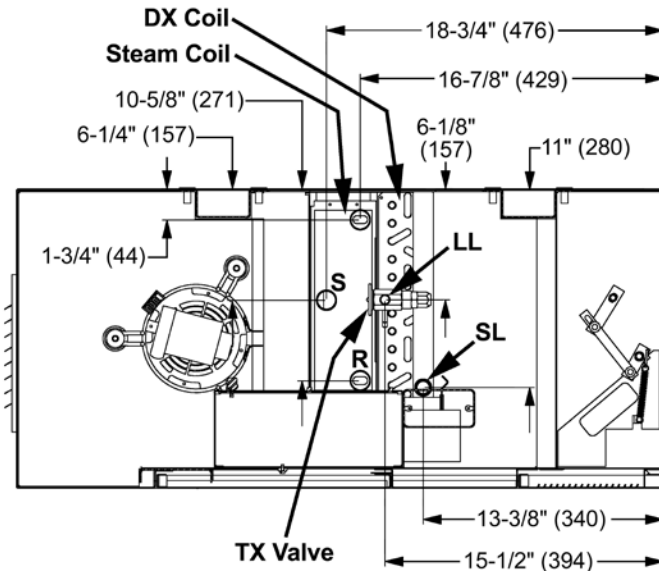

Figure 56: Direct Expansion (1st Position) and Steam Unit (Cooling Coil G[9], M[0], Heating Coils 68, 69)



Reheat Units (Right Hand)

- Notes:** 1. Linear dimensions referenced from rear of unit.
 Right hand views shown, dimensions are identical for left-hand configurations. Connection hand is determined by facing discharge air grille.
 2. Numerical codes [#] denote optional stainless steel drain pan (cooling coils).

Figure 58: Chilled Water & Hot Water Unit (Cooling Coils V[5], S[6], W[7], Y[8]; Heating Coils 65, 66, 67)

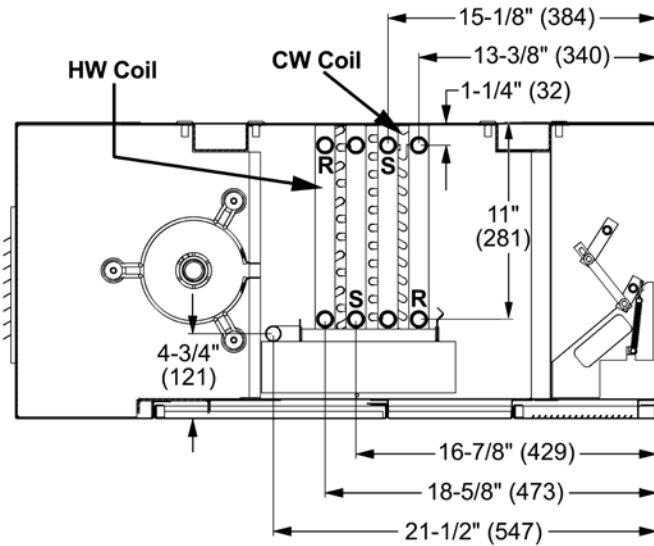

Figure 59: Chilled Water and Steam Unit (Cooling Coils V [5], S[6]; Heating Coils 68, 69)

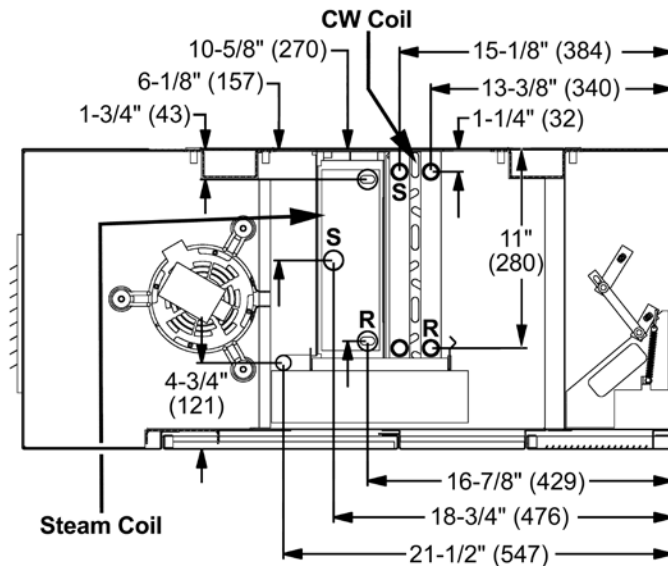

Figure 60: Chilled Water (1st Position) & Electric Heating (Cooling Coils V[5], S[6], W[7]; Heating Coil 12, 13)

Note: Electric heat, right hand only. Chilled water left hand only

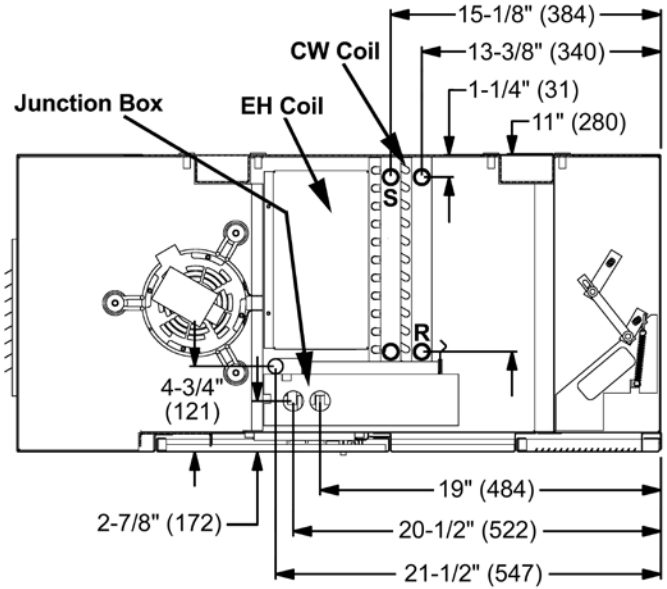

Figure 61: Direct Expansion and Hot Water Unit (Cooling Coil G[9], M[0], Heating Coils 65, 66, 67)

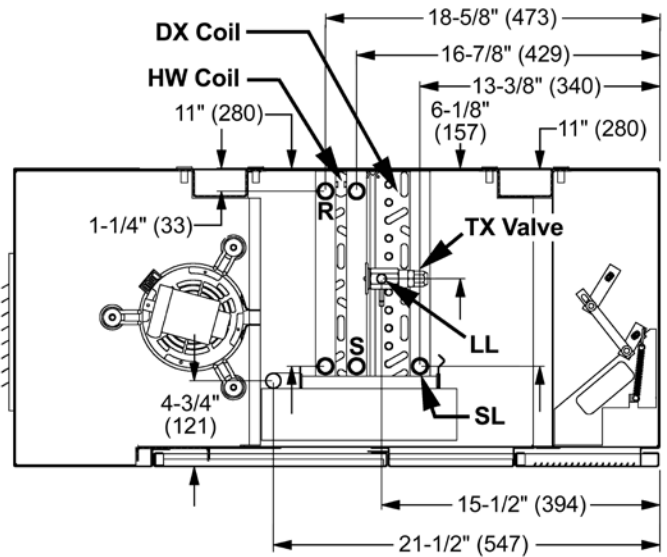

Figure 62: Direct Expansion and Steam Unit (Cooling Coil G[9], M[0], Heating Coils 68, 69)

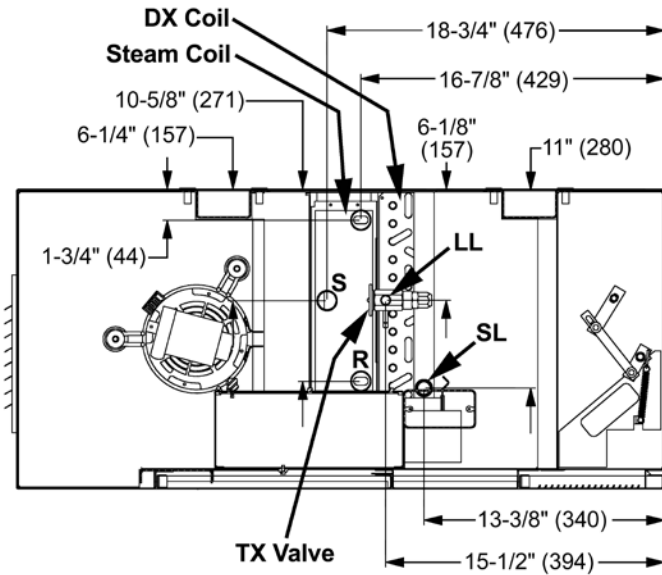
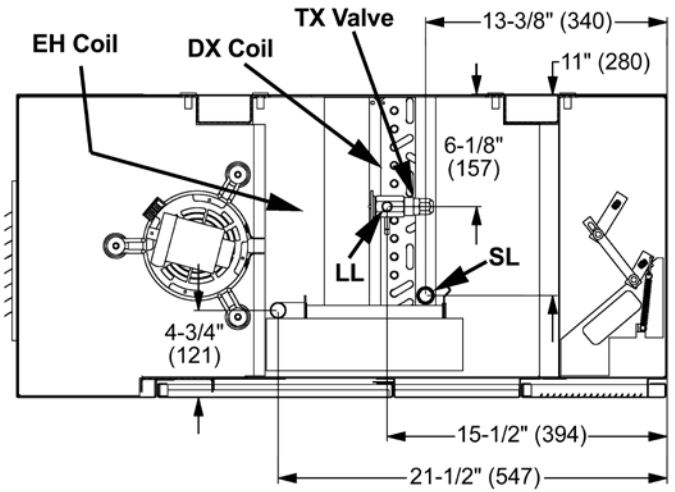

Figure 63: Direct Expansion & Electric Heating Unit (Cooling Coil G[9], M[0], Heating Coils 12, 13)



Heating Only Units

Note: Dimensions are same for left hand units. Connection hand is determined by facing discharge air grille.

Figure 64: Hot Water Heating Only Unit (Coils 65, 66, 67)

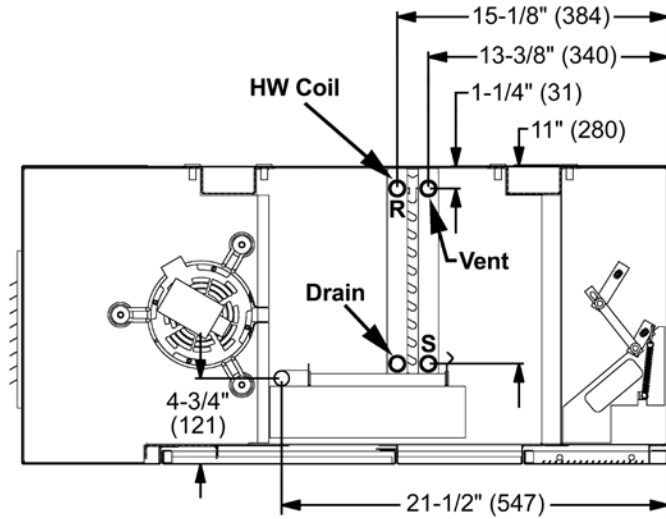

Figure 65: Steam Heating Only Unit (Coils 68, 69)

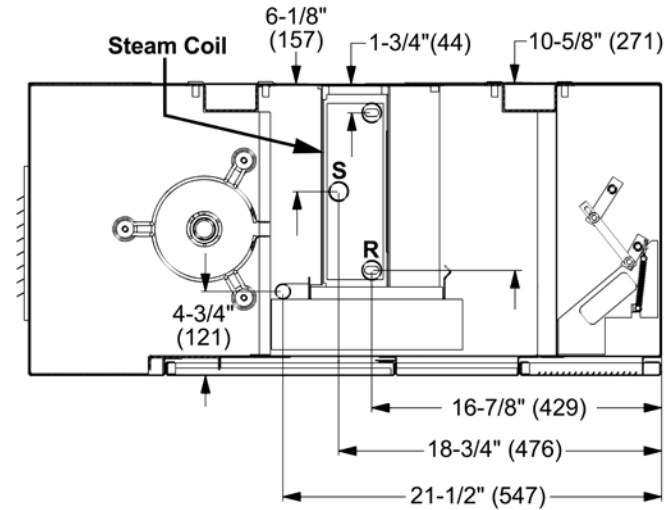
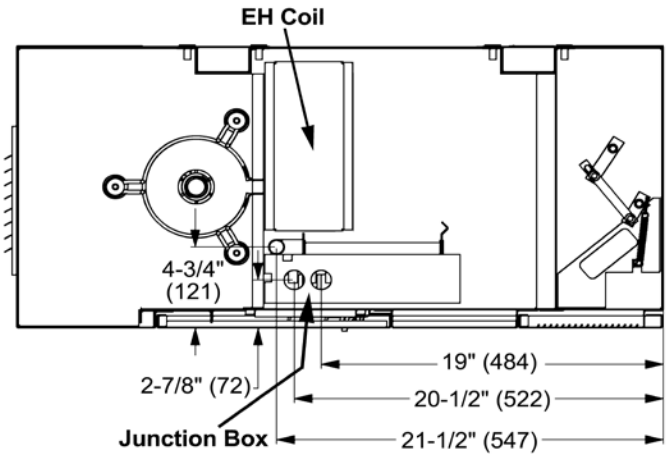

Figure 66: Electric Heating Only Unit (Coils 12, 13)

Note: This arrangement available on AHV units only.



Cooling Only Units (Right Hand)

- Notes:** 1. Linear dimensions referenced from rear of unit.
 Right hand views shown, dimensions are identical for left-hand configurations. Connection hand is determined by facing discharge air grille.
 2. Numerical codes [#] denote optional stainless steel drain pan (cooling coils).

Figure 67: Chilled Water Cooling Only Unit (Coils V[5], S[6], W[7], Y[8])

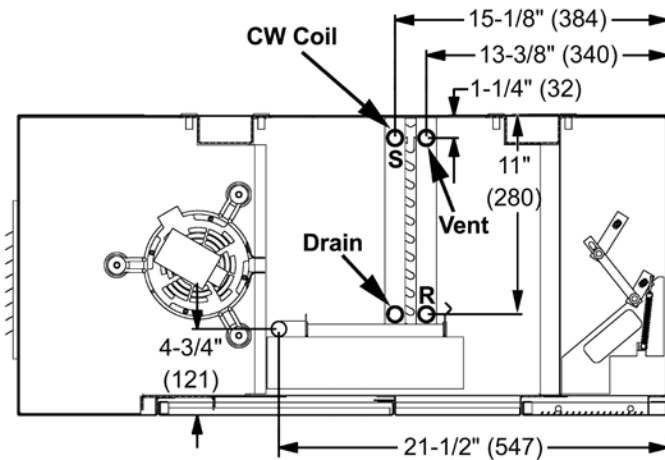
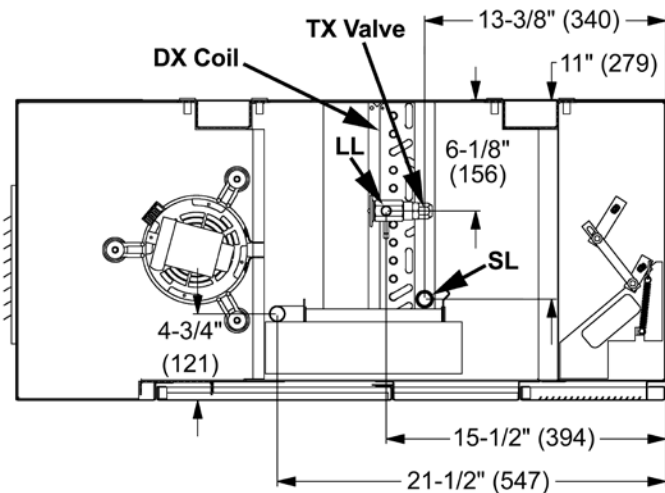

Figure 68: Direct Expansion Cooling Only Unit (Coil G[9], M[0])



Condensate Drain Connections

- Note:** Dimensions exclude 1" (25 mm) end panel.
 Condensate drain stub is 7/8" (22 mm) x 1/8" (3 mm) wall thickness.

Figure 69: Condensate Drain

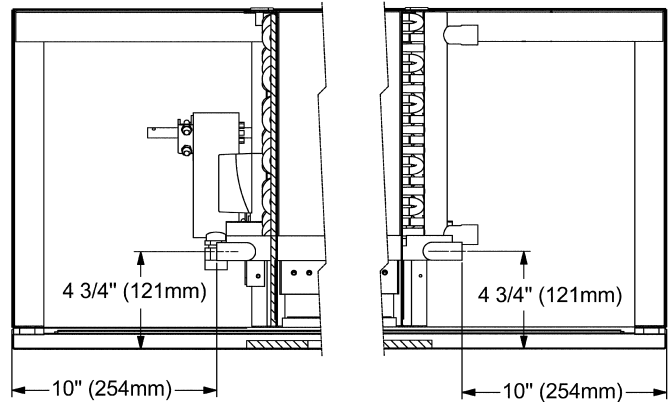
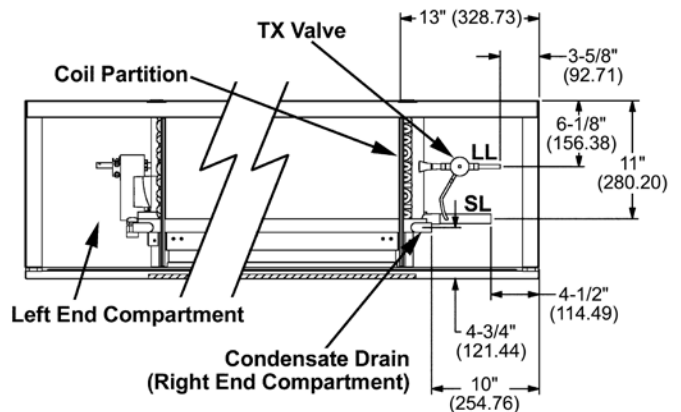

Figure 70: Condensate Drain & DX Coil Connections



Face & Bypass End of Cycle Valves

2-Way End of Cycle Valve



When piping the 2-Way End of Cycle valve, refer to label to determine the direction of flow. The valve should be installed so that there is a 2" (51mm) minimum clearance to remove the actuator from the valve body. Provide unions for removal of unit coil and/or control valve as a future service consideration. Hot water connections may be same end as cooling coil connections, but are recommended to be opposite end to facilitate piping.

When using MicroTech® controls, they must be opposite end. The End of Cycle valve accessory must be field installed on the unit for which it was selected.

Figure 71: 2-Way EOC Valve Dimensions

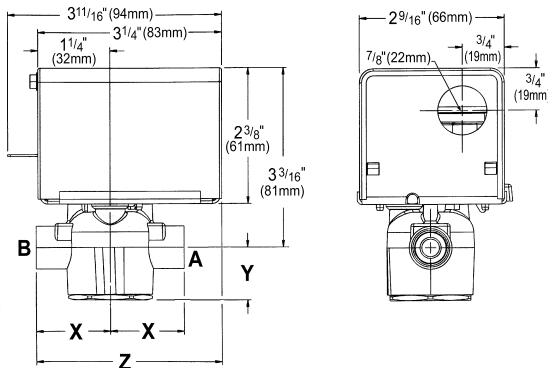

| Connection | Cv | X | Y | Z |
|------------------|-----|-----------------|----------------|---------------|
| 3/4" (19mm) FNPT | 7.5 | 1 11/16" (43mm) | 1 5/16" (24mm) | 3 5/8" (92mm) |

3-Way End of Cycle Valve



When piping the 3-Way End of Cycle valve, refer to label to determine the direction of flow. The valve should be installed so that there is a 2" (51mm) minimum clearance to remove the actuator from the valve body. Provide unions for removal of unit coil and/or control valve as a future service consideration. Hot water connections

may be same end as cooling coil connections, but are recommended to be opposite end to facilitate piping.

When using MicroTech® controls, they must be opposite end. The End of Cycle valve accessory must be field installed on the unit for which it was selected.

Figure 72: 3-Way EOC Valve Dimensions

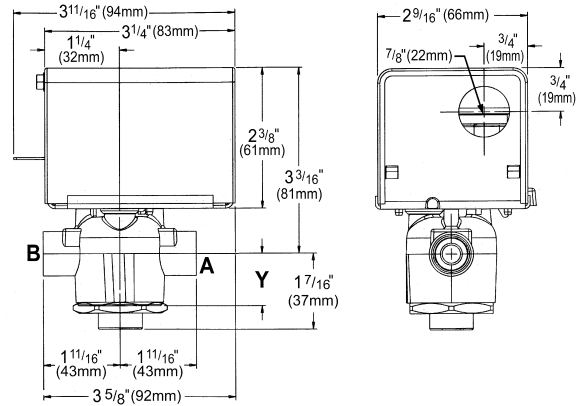

| Connection | Cv | Y |
|------------------|-----|----------------|
| 3/4" (19mm) FNPT | 5.0 | 1 5/16" (24mm) |

Figure 73: 2-Way EOC Steam Valve Dimensions

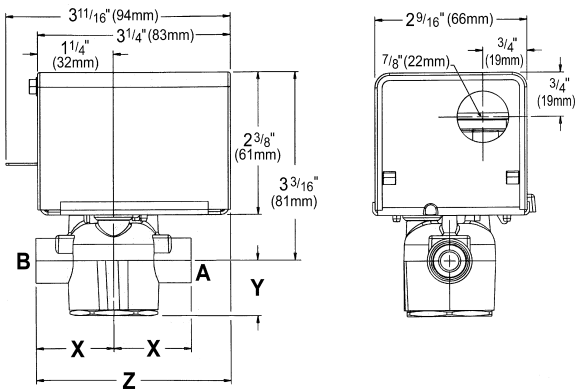

| Connection | Cv | X | Y | Z |
|----------------|-----|---------------|-----------|-----------------|
| 1" (25mm) FNPT | 8.0 | 1 1/8" (47mm) | 1" (25mm) | 3 11/16" (94mm) |

Table 10: EOC Actuator Specifications

| | |
|------------|--|
| Control | 2 Position |
| Electrical | 24 VAC, 50/60 Hz |
| Stroke | Power Stroke 9 to 11 seconds Spring return 4 to 5 seconds |
| Ambient | 32°F to 125°F (0°C to 52°C) |

Table 11: F&BP EOC Valve Body Specifications

| | 2-Way Valve | 3-Way Valve |
|--------------------|-----------------------------|-----------------------------|
| Connections | 3/4" FNPT, 1" FNPT | 3/4" FNPT |
| Static Pressure | 300 psi (2100 kPa) | 300 psi (2100 kPa) |
| Close-Off Pressure | 13 & 15 psi (90 & 103 kPa) | 13 psi (90 kPa) |
| Temperature | 32°F to 200°F (0°C to 93°C) | 32°F to 200°F (0°C to 93°C) |

2-Way Modulating Valve (Chilled Water, Hot Water or Combination)



Two-way modulating control valves for MicroTech are designed to regulate the flow of chilled water, hot water or the combination. They consist of a nickel plated brass body and stainless steel ball valve and stem, with a spring return proportional actuator. The optional valve accessory is shipped separate from the unit ventilator for field installation to prevent shipping damage and to provide flexibility in making the field piping connection.

Table 12: 2-Way Actuator Specifications (CW, HW, CW/HW)

| | |
|-----------------------------------|--|
| Power Supply | 24 VAC, ±20%, 50/60 Hz, 24 VDC, ±10% |
| Power Consumption Running | 2 W |
| Power Consumption Holding | 1 W |
| Transformer Sizing | 4 VA (class 2 power source) |
| Electrical Connection | 3ft [1m], 18 GA plenum cable with 1/2" conduit connector |
| Overload Protection | electronic throughout 0° to 95° rotation |
| Operating Range Y | 2 to 10 VDC, 4 to 20 mA w/ ZG-R01 (500 Ω, 1/4 W resistor) |
| Input Impedance | 100 k Ω for 2 to 10 VDC (0.1 mA), 500 Ω for 4 to 20 mA |
| Feedback Output U | 2 to 10 VDC, 0.5 mA max |
| Angle of Rotation | Max. 95°, 90° |
| Direction of Rotation (Motor) | reversible with built-in switch |
| Direction of Rotation (Fail-Safe) | reversible with CW/CCW mounting |
| Position Indication | visual indicator, 0° to 95° (0° is full spring return position) |
| Running Time (Motor) | 95 sec |
| Running Time (Fail-Safe) | <25 sec |
| Ambient Humidity | max. 95% RH non-condensing |
| Ambient Temperature Range | -22°F to 122°F [-30°C to 50°C] |
| Storage Temperature Range | -40°F to 176°F [-40°C to 80°C] |
| Housing | NEMA 2, IP42, UL Enclosure Type 2 |
| Housing Material | UL94-5VA |
| Agency Listings ¹ | cULus acc. to UL60730-1A/-2-14, CAN/CSA E60730-1:02, CE acc. to 2004/108/EC and 2006/95/EC |
| Noise Level (Motor) | <35 dB (A) |
| Noise Level (Fail-Safe) | <62 dB (A) |
| Servicing | maintenance free |
| Quality Standard | ISO 9001 |

Note: ¹ Rated Impulse Voltage 800V, Type of action 1.AA, Control Pollution Degree 3TFRB24

Table 13: 2-Way Valve Body Specifications (CW, HW, CW/HW)

| | |
|-----------------------------------|--------------------------------------|
| Service | chilled, hot water, up to 60% glycol |
| Flow Characteristic | equal percentage |
| Controllable Flow Range | 75° |
| Size [mm] | 0.5" [15] |
| End Fitting | NPT female ends |
| Body | forged brass, nickel plated |
| Ball | stainless steel |
| Stem | stainless steel |
| Stem Packing | EPDM (lubricated) |
| Seat | Teflon® PTFE |
| Seat O-ring | EPDM (lubricated) |
| Characterized Disc | TEFZEL® |
| Body Pressure Rating [psi] | 600 |
| Media Temperature Range (Water) | 0°F to 250°F [-18°C to 120°C] |
| Max Differential Pressure (Water) | 50 psi (345 kPa) |
| Close-Off Pressure | 200 psi |
| Leakage | 0% for A to AB |
| Servicing | maintenance free |

2-Way Modulating Valve Specifications (CW, HW, CW/HW)

Modulating Valve Selection

The unit ventilator control valve is expected to be able to vary the quantity of water that flows through the coil in a modulating fashion. Any movement of the valve stem should produce some change in the amount of water that flows through the coil. Oversized control valves cannot do this. For example, assume that when the control valve is fully open, the pressure drop through the coil is twice as great as the drop through the valve. In this case, the control valve must travel to approximately 50% closed before it can begin to have any influence on the water flow through the coil. The control system, no matter how sophisticated, cannot overcome this. Oversized control valves can also

result in “hunting” which will shorten the life of the valve and actuator and possibly damage the coil.

To correctly select the proper Chilled Water Modulating Valve:

1. Determine the flow of water and the corresponding pressure drop through the coil.
2. Obtain the pressure difference between the supply and return mains.
3. Select a valve size (Cv) from [Table 15](#), on the basis of taking 50% of the available pressure difference (at design flow) between the supply and return mains at the valve location. The valve should have a pressure drop greater than that of the coil.

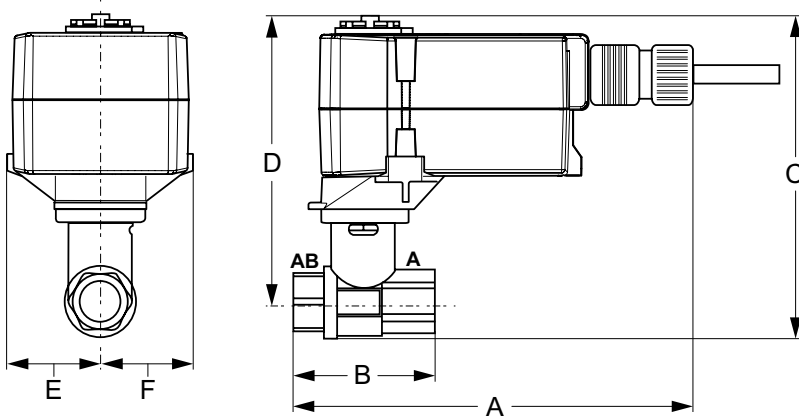

Figure 74: Formula Equation to Calculate Cv

Q = Capacity in gallons per minute

Cv = Valve sizing coefficient determined experimentally for each style and size of valve, using water at standard conditions as the test fluid

ΔP = Pressure differential in psi

G = Specific gravity of fluid (water at 60°F = 1.0000)

$$Cv = Q \sqrt{\frac{G}{\Delta P}}$$

Table 14: 2-Way Modulating Valve 1/2" – Dimensions (CW, HW, CW/HW)

| Valve Part No. | Cv | Connection Size (inches) | A | B | C | D | E | F | Weight | |
|----------------|-----|--------------------------|------------------|-----------------|------------------|------------------|--------------|---------------------|--------------------|----------|
| | | | | | | | | | Valve Body | Actuator |
| B209 | 0.8 | 1/2" | 6.59" (167mm) | 2.38" (60mm) | 4.9" (124mm) | 4.32" (110mm) | 1.53" (38mm) | 0.4 lb (0.2 kg) | 1.8 lb (0.8 kg) | |
| B210 | 1.2 | | | | | | | | | |
| B211 | 1.9 | | | | | | | | | |
| B212 | 3.0 | | 6.59" (167mm) | 2.38" (60mm) | 5.48" (139mm) | 4.71" (120mm) | 1.53" (38mm) | 0.7 lb. (0.3 kg) | | |
| B213 | 4.7 | | | | | | | | | |
| B214 | 7.4 | | | | | | | | | |

Note: See "Table 12: 2-Way Actuator Specifications (CW, HW, CW/HW)" on page 41" and "Table 13: 2-Way Valve Body Specifications (CW, HW, CW/HW)" on page 41.

Table 15: 2-Way Modulating Water Valve 1/2" – Pressure Drop (CW, HW, CW/HW)

| 2-Way CCV Part No. | Cv Maximum Rating | Connection Size | Pressure Drop Across the Valve | | | | | | | | | |
|--------------------|-------------------|-----------------|--------------------------------|-------|-------|-------|-------|-------|-------|-------|-------|--------|
| | | | 1 PSI | 2 PSI | 3 PSI | 4 PSI | 5 PSI | 6 PSI | 7 PSI | 8 PSI | 9 PSI | 10 PSI |
| B209 | 0.8 | 1/2" | 0.8 | 1.1 | 1.4 | 1.6 | 1.8 | 2.0 | 2.1 | 2.3 | 2.4 | 2.5 |
| B210 | 1.2 | | 1.2 | 1.7 | 2.1 | 2.4 | 2.8 | 2.9 | 3.2 | 3.4 | 3.6 | 3.8 |
| B211 | 1.9 | | 1.9 | 2.7 | 3.3 | 3.8 | 4.2 | 4.7 | 5.0 | 5.4 | 5.7 | 6.0 |
| B212 | 3.0 | | 3.0 | 4.2 | 5.2 | 6.0 | 6.8 | 7.3 | 7.9 | 8.5 | 9.0 | 9.5 |
| B213 | 4.7 | | 4.7 | 6.6 | 8.1 | 9.4 | 11 | 12 | 12 | 13 | 14 | 15 |
| B214 | 7.4 | | 7.4 | 10 | 13 | 15 | 17 | 18 | 20 | 21 | 22 | 23 |

2-Way Modulating Valve (Steam) - 1/2"



Two-way modulating control valves for MicroTech are designed to regulate the flow of steam. They consist of a nickel plated brass body and stainless steel ball valve and stem, with a spring return, proportional actuator. The optional valve accessory is shipped separate from the unit ventilator for field installation to prevent shipping damage and to provide flexibility in making the field piping connection.

Table 16: 2-Way Actuator Specifications (Steam)

| | |
|-----------------------------------|--|
| Power Supply | 24 VAC ± 20%, 50/60 Hz, 24 VDC ± 10% |
| Power Consumption Running | 2 W |
| Power Consumption Holding | 1 W |
| Transformer Sizing | 4 VA (class 2 power source) |
| Electrical Connection | 3ft [1m], 18 GA plenum cable with 1/2" conduit connector" |
| Overload Protection | electronic throughout 0° to 95° rotation |
| Operating Range Y | 2 to 10 VDC, 4 to 20 mA w/ ZG-R01 (500 Ω, 1/4 W resistor) |
| Input Impedance | 100 k Ω for 2 to 10 VDC (0.1 mA), 500 Ω for 4 to 20 mA |
| Feedback Output U | 2 to 10 VDC, 0.5 mA max |
| Angle of Rotation | Max. 95°, 90° |
| Direction of Rotation (Motor) | reversible with built-in switch |
| Direction of Rotation (Fail-Safe) | reversible with CW/CCW mounting |
| Position Indication | visual indicator, 0° to 95° (0° is full spring return position) |
| Running Time (Motor) | 95 sec |
| Running Time (Fail-Safe) | <25 sec |
| Ambient Humidity | max. 95% RH non-condensing |
| Ambient Temperature Range | -22°F to 122°F [-30°C to 50°C] |
| Storage Temperature Range | -40°F to 176°F [-40°C to 80°C] |
| Housing | NEMA 2, IP42, UL enclosure type 2 |
| Housing Material | UL94-5VA |
| Agency Listings ¹ | cULus acc. to UL60730-1A/-2-14, CAN/CSA E60730-1:02, CE acc. to 2004/108/EC and 2006/95/EC |
| Noise Level (Motor) | <35 dB (A) |
| Noise Level (Fail-Safe) | <62 dB (A) |
| Servicing | maintenance free |
| Quality Standard | ISO 9001 |

Note: ¹ Rated Impulse Voltage 800V, Type of action 1.AA, Control Pollution Degree 3

Table 17: Valve Body Specifications (Steam)

| | |
|---------------------------------------|---|
| Service | high temperature hot water/low pressure steam, up to 60% glycol |
| Flow Characteristic | A-port equal percentage |
| Controllable Flow Range | 75° |
| Size [mm] | 0.5" [15] |
| End Fitting | NPT female ends |
| Body | nickel plated brass (DZR) P-CuZn35Pb2 |
| Ball | stainless steel |
| Stem | stainless steel |
| Stem Packing | Viton O-ring |
| Seat | ETFE |
| Seat O-ring | EPDM (lubricated) |
| Characterized Disc | ETFE |
| Body Pressure Rating [psij] | 600 |
| Max Inlet Pressure (Steam) | 15 psi |
| Media Temperature Range (Water) | 60°F to 266°F [16°C to 130°C] |
| Media Temperature Range (Steam) | 250°F [120°C] |
| Maximum Differential Pressure (Steam) | 15 psi |
| Max Differential Pressure (Water) | 60 psi partially open ball, 116 psi full open |
| Close-Off Pressure | 200 psi |
| Leakage | 0% |
| Servicing | maintenance free |

2-Way Modulating Steam Valve Specifications

Modulating Steam Valve Selection

The steam modulating control valve is expected to vary the quantity of steam through the coil. Any movement of the valve stem should produce some change in the steam flow rate. To select a modulating steam valve:

1. Obtain the supply steam inlet pressure.
2. Determine the actual heat requirement of the space to be heated.

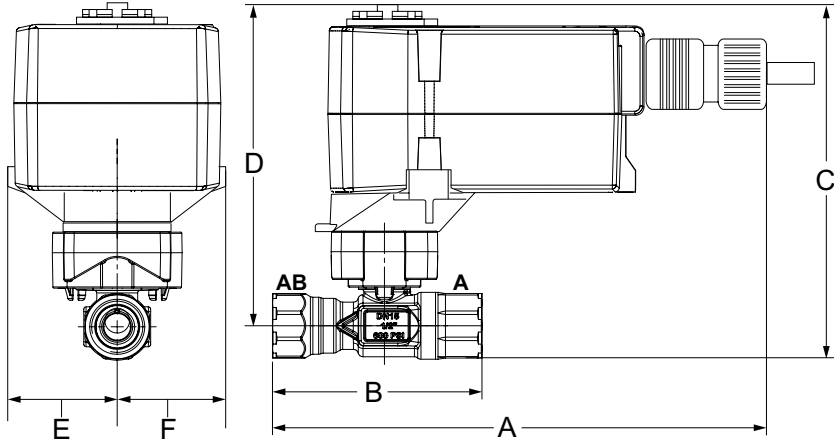

Table 18: 2-Way Modulating Steam Valve 1/2" – Dimensions

| Valve Part No. | Cv | Connection Size (inches) | A | B | C | D | E | F | Weight | |
|----------------|------|--------------------------|------------------|-----------------|-----------------|-----------------|-----------------|-------------------|-----------------|-----------------|
| | | | | | | | | | Valve Body | Actuator |
| B215HT073 | 0.73 | 1/2" | 7.32" (186mm) | 3.33" (85mm) | 5.8" (147mm) | 5.3" (135mm) | 1.52" (39mm) | 1.52" (38.5mm) | 0.7 lb [0.3 kg] | 1.8 lb [0.8 kg] |
| B215HT186 | 1.86 | | | | | | | | | |
| B215HT455 | 4.55 | | | | | | | | | |

Note: See "Table 16: 2-Way Actuator Specifications (Steam)" on page 43" and "Table 17: Valve Body Specifications (Steam)" on page 43.

Table 19: 2-Way Modulating Steam Valve 1/2" – Pressure Drop

| 2-Way CCV Part No. | Cv Maximum Rating | Connection Size | Pressure Drop Across the Valve | | | | | |
|--------------------|-------------------|-----------------|--------------------------------|-------|--------|--------|--------|--------|
| | | | 2 PSI | 3 PSI | 4 PSI | 5 PSI | 10 PSI | 15 PSI |
| B215HT073 | 0.73 | 1/2" | 10.99 | 13.71 | 16.11 | 18.33 | 28.03 | 36.74 |
| B215HT186 | 1.86 | | 22.34 | 34.93 | 41.06 | 46.70 | 71.42 | 93.60 |
| B215HT455 | 4.55 | | 54.65 | 85.44 | 100.43 | 114.24 | 174.72 | 228.97 |

2-Way Modulating Valve (Steam) - 3/4"



The modulating control valves for MicroTech are designed to regulate the flow of steam. They consist of a nickel plated brass body and stainless steel ball valve and stem, with a spring return, proportional actuator. The optional valve accessory is shipped separate from the unit ventilator for field installation to prevent shipping damage and to provide flexibility in making the field piping connection.

Table 20: Actuator Specifications

| | |
|-----------------------------------|--|
| Power Supply | 24 VAC ± 20%, 50/60 Hz, 24 VDC ± 10% |
| Power Consumption Running | 2.5 W |
| Power Consumption Holding | 1 W |
| Transformer Sizing | 5 VA (class 2 power source) |
| Electrical Connection | 3ft [1m], 18 GA plenum cable with 1/2" conduit connector |
| Overload Protection | electronic throughout 0° to 95° rotation |
| Operating Range Y | 2 to 10 VDC, 4 to 20 mA w/ ZG-R01 (500 Ω, 1/4 W resistor) |
| Input Impedance | 100 k Ω for 2 to 10 VDC (0.1 mA), 500 Ω for 4 to 20 mA |
| Feedback Output U | 2 to 10 VDC (max 0.7 mA) for 95° |
| Angle of Rotation | 90° |
| Direction of Rotation (Motor) | reversible with built-in switch |
| Direction of Rotation (Fail-Safe) | reversible with CW/CCW mounting |
| Position Indication | visual indicator, 0° to 95° (0° is full spring return position) |
| Running Time (Motor) | 150 sec constant, independent of load |
| Running Time (Fail-Safe) | <25 sec @ -4°F to 122°F [-20°C to 50°C], < 60 sec @ -22°F [-30°C]" |
| Ambient Temperature Range | -22°F to 122°F [-30°C to 50°C] |
| Storage Temperature Range | -40°F to 176°F [-40°C to 80°C] |
| Housing | NEMA 2, IP54 |
| Agency Listings ¹ | cULus acc. To UL 873 and CAN/CSA C22.2 No. 24-93" |
| Noise Level (Motor) | <50 dB (A) |
| Noise Level (Fail-Safe) | <62 dB (A) |
| Servicing | maintenance free |
| Quality Standard | ISO 9001 |

Note: ¹ Rated Impulse Voltage 800V, Type of action 1.AA, Control Pollution Degree 3

Table 21: Valve Body Specifications

| | |
|---------------------------------------|---|
| Service | high temperature hot water/low pressure steam, up to 60% glycol |
| Flow Characteristic | A-port equal percentage |
| Controllable Flow Range | 75° |
| Size [mm] | 0.75" [20] |
| End Fitting | NPT female ends |
| Body | nickel plated brass (DZR) P-CuZn35Pb2 |
| Ball | stainless steel |
| Stem | stainless steel |
| Stem Packing | Viton O-ring |
| Seat | ETFE |
| Seat O-ring | EPDM (lubricated) |
| Characterized Disc | ETFE |
| Body Pressure Rating [psi] | 600 |
| Max Inlet Pressure (Steam) | 15 psi |
| Media Temperature Range (Water) | 60°F to 266°F [16°C to 130°C] |
| Media Temperature Range (Steam) | 250°F [120°C] |
| Maximum Differential Pressure (Steam) | 15 psi |
| Max Differential Pressure (Water) | 60 psi partially open ball, 116 psi full open |
| Close-Off Pressure | 200 psi |
| Leakage | 0% |
| Servicing | maintenance free |

2-Way Modulating Steam Valve Specifications

Modulating Steam Valve Selection

The steam modulating control valve is expected to vary the quantity of steam through the coil. Any movement of the valve stem should produce some change in the steam flow rate. To select a modulating steam valve:

1. Obtain the supply steam inlet pressure.
2. Determine the actual heat requirement of the space to be heated.

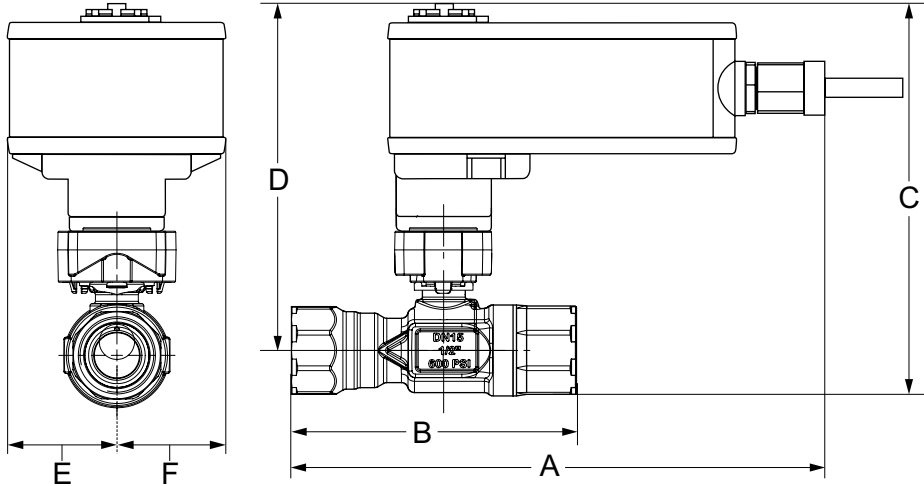

Table 22: 2-Way Modulating Valve 3/4" – Dimensions

| Valve Part No. | Cv | Connection Size (inches) | A | B | C | D | E | F | Weight | |
|----------------|------|--------------------------|------------------|------------------|------------------|------------------|-----------------|-----------------|---------------------|--------------------|
| | | | | | | | | | Valve Body | Actuator |
| B220HT731 | 7.31 | 3/4 inch | 8.70" (221mm) | 3.96" (101mm) | 6.74" (171mm) | 6.07" (154mm) | 1.89" (48mm) | 1.89" (48mm) | 0.9 lb. (0.4 kg) | 1.8 lb (0.8 kg) |

Note: See "Table 20: Actuator Specifications" on page 45" and "Table 21: Valve Body Specifications" on page 45.

Table 23: 2-Way Modulating Steam Valve 3/4" – Pressure Drop

| 2-Way CCV Part No. | Cv Maximum Rating | Connection Size | Pressure Drop Across the Valve | | | | | |
|--------------------|-------------------|-----------------|--------------------------------|--------|--------|--------|--------|--------|
| | | | 2 PSI | 3 PSI | 4 PSI | 5 PSI | 10 PSI | 15 PSI |
| B220HT731 | 7.31 | 3/4 inch | 110.02 | 137.27 | 161.36 | 183.54 | 280.70 | 367.86 |

3-Way Modulating Valve (Chilled Water, Hot Water or Combination)



Three-way modulating control valves for MicroTech are designed to regulate the flow of hot or chilled water or the combination. They consist of a nickel plated brass body and stem with chrome plated brass ball valve, with a spring return, proportional actuator. The optional valve accessory is shipped separate from the unit ventilator for field installation to prevent shipping damage and to provide flexibility in making the field piping connection.

Table 24: 3-Way Actuator Specifications (CW, HW, CW/HW)

| | |
|-----------------------------------|--|
| Power Supply | 24 VAC, ±20%, 50/60 Hz, 24 VDC, ±10% |
| Power Consumption Running | 2 W |
| Power Consumption Holding | 1 W |
| Transformer Sizing | 4 VA (class 2 power source) |
| Electrical Connection | 3ft [1m], 18 GA plenum cable with 1/2" conduit connector |
| Overload Protection | electronic throughout 0° to 95° rotation |
| Operating Range Y | 2 to 10 VDC, 4 to 20 mA w/ ZG-R01 (500 Ω, 1/4 W resistor) |
| Input Impedance | 100 k Ω for 2 to 10 VDC (0.1 mA), 500 Ω for 4 to 20 mA |
| Feedback Output U | 2 to 10 VDC, 0.5 mA max |
| Angle of Rotation | Max. 95°, 90° |
| Direction of Rotation (Motor) | reversible with built-in switch |
| Direction of Rotation (Fail-Safe) | reversible with CW/CCW mounting |
| Position Indication | visual indicator, 0° to 95° (0° is full spring return position) |
| Running Time (Motor) | 95 sec |
| Running Time (Fail-Safe) | <25 sec |
| Ambient Humidity | max. 95% RH non-condensing |
| Ambient Temperature Range | -22°F to 122°F [-30°C to 50°C] |
| Storage Temperature Range | -40°F to 176°F [-40°C to 80°C] |
| Housing | NEMA 2, IP42, UL Enclosure Type 2 |
| Housing Material | UL94-5VA |
| Agency Listings ¹ | cULus acc. to UL60730-1A/-2-14, CAN/CSA E60730-1:02, CE acc. to 2004/108/EC and 2006/95/EC |
| Noise Level (Motor) | <35 dB (A) |
| Noise Level (Fail-Safe) | <62 dB (A) |
| Servicing | maintenance free |
| Quality Standard | ISO 9001 |

Note: ¹ Rated Impulse Voltage 800V, Type of action 1.AA, Control Pollution Degree 3

Table 25: 3-Way Valve Body Specifications (CW, HW, CW/HW)

| | |
|-----------------------------------|---|
| Service | chilled, hot water, up to 60% glycol |
| Flow Characteristic | A-port Equal percentage; B-port modified linear for constant flow |
| Controllable Flow Range | 75° |
| Size [mm] | 0.5" [15] |
| End Fitting | npt female ends |
| Body | forged brass, nickel plated |
| Ball | chrome plated brass |
| Stem | nickel plated brass |
| Stem Packing | EPDM (lubricated) |
| Seat | Teflon® PTFE |
| Seat O-ring | EPDM (lubricated) |
| Characterized Disc | TEFZEL® |
| Body Pressure Rating [psi] | 600 |
| Media Temperature Range (Water) | 0°F to 250°F [-18°C to 120°C] |
| Max Differential Pressure (Water) | 50 psi (345 kPa) |
| Close-Off Pressure | 200 psi |
| Leakage | 0% for A to AB, <2.0% for B to AB |
| Servicing | maintenance free |

3-Way Modulating Valve Specifications

Hot Water, Chilled Water or 2-Pipe CW/HW Modulating Valve Selection

The unit ventilator control valve is expected to be able to vary the quantity of water that flows through the coil in a modulating fashion. Any movement of the valve stem should produce some change in the amount of water that flows through the coil. Oversized control valves cannot do this. For example, assume that when the control valve is fully open, the pressure drop through the coil is twice as great as the drop through the valve.

In this case, the control valve must travel to approximately 50% closed before it can begin to have any influence on the water flow through the coil. The

control system, no matter how sophisticated, cannot overcome this. Oversized control valves can also result in “hunting” which will shorten the life of the valve and actuator and possibly damage the coil.

To correctly select the proper Hot Water, Chilled Water or 2-pipe CW/HW Modulating Valve:

1. Determine the flow of water and the corresponding pressure drop through the coil.
2. Obtain the pressure difference between the supply and return mains.
3. Select a valve size (Cv) from [Table 27](#), on the basis of taking 50% of the available pressure difference (at design flow) between the supply and return mains at the valve location. The valve should have a pressure drop greater than that of the coil.

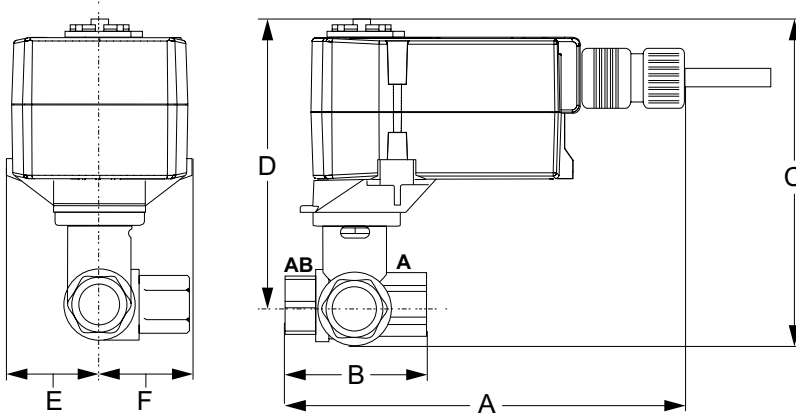

Figure 75: Formula Equation to Calculate Cv

Q = Capacity in gallons per minute

Cv = Valve sizing coefficient determined experimentally for each style and size of valve, using water at standard conditions as the test fluid

ΔP = Pressure differential in psi

G = Specific gravity of fluid (water at 60°F = 1.0000)

$$Cv = Q \sqrt{\frac{G}{\Delta P}}$$

Table 26: 3-Way Modulating Valve 1/2" – Dimensions

| Valve Part No. | Cv | Connection Size (inches) | A | B | C | D | E | F | Weight | |
|----------------|-----|--------------------------|------------------|-----------------|-----------------|------------------|-----------------|-----------------|---------------------|---------------------|
| | | | | | | | | | Valve Body | Actuator |
| B309(B) | 0.8 | 1/2" | 6.59" (167mm) | 2.38" (60mm) | 4.9" (124mm) | 4.32" (110mm) | 1.53" (38mm) | 1.2" (31mm) | .07 lb. (.03 kg) | 1.8 lb. (.08 kg) |
| B310(B) | 1.2 | | | | | | | | | |
| B311(B) | 1.9 | | | | | | | | | |
| B312(B) | 3.0 | | 6.59" (167mm) | 2.38" (60mm) | 4.9" (124mm) | 4.71" (120mm) | 1.53" (38mm) | 1.29" (33mm) | | |
| B313(B) | 4.7 | | | | | | | | | |
| B318(B) | 7.4 | | | | | | | | | |

Note: See "Table 24: 3-Way Actuator Specifications (CW, HW, CW/HW)" on page 47" and "Table 25: 3-Way Valve Body Specifications (CW, HW, CW/HW)" on page 47.

Table 27: Modulating 3-Way Hot Water, Chilled Water or 2-Pipe CW/HW Valve 1/2" – Pressure Drop

| 2-Way CCV Part No. | Cv Maximum Rating | Connection Size | Pressure Drop Across the Valve | | | | | | | | | |
|--------------------|-------------------|-----------------|--------------------------------|-------|-------|-------|-------|-------|-------|-------|-------|--------|
| | | | 1 PSI | 2 PSI | 3 PSI | 4 PSI | 5 PSI | 6 PSI | 7 PSI | 8 PSI | 9 PSI | 10 PSI |
| B309(B) | 0.8 | 1/2" | 0.8 | 1. | 1.4 | 1.6 | 1.8 | 2.0 | 2. | 2.3 | 2.4 | 2.5 |
| B310(B) | 1.2 | | 1.2 | 1.7 | 2. | 2.4 | 2.8 | 2.9 | 3.2 | 3.4 | 3.6 | 3.8 |
| B311(B) | 1.9 | | 1.9 | 2.7 | 3.3 | 3.8 | 4.2 | 4.7 | 5.0 | 5.4 | 5.7 | 6.0 |
| B312(B) | 3.0 | | 3.0 | 4.2 | 5.2 | 6.0 | 6.8 | 7.3 | 7.9 | 8.5 | 9.0 | 9.5 |
| B313(B) | 4.7 | | 4.7 | 6.6 | 8.1 | 9.4 | 11 | 12 | 12 | 13 | 14 | 15 |
| B318(B) | 7.4 | | 7.4 | 10 | 13 | 15 | 17 | 18 | 20 | 21 | 22 | 23 |

Wall Intake Louvers & Grilles

Louvers are available in both horizontal and vertical blade configurations:

- **Horizontal blade** construction turns the incoming air to keep moisture from entering. Bottom weep holes drain moisture to the outside.
- **Vertical-blade** construction provides positive water impingement and entrapment. The bottom lip drains moisture to the outside.

Louvers can be supplied with or without flanges:

- **Flanged louvers** are typically used for a panel wall finish.
- **Unflanged louvers** are typically used for recessing into a masonry wall.

A half-inch-square mesh bird screen located on the leaving air side of the louver prevents birds and other small animals from entering. The screen's strong aluminum mesh is designed to minimize air pressure drops, unlike expanded metal mesh.

Table 28: Louver Specifications

| Unit | Nominal Air Flow | | Louver Dimensions ± 1/16" (± 2mm) | | Recommended Wall Opening | |
|------------------|------------------|-----|-----------------------------------|--------------------|--------------------------|--------------------|
| | CFM | L/s | L = Length | Height | Length | Height |
| H07, V07 | 750 | 354 | 36" (914mm) | 10-3/8" (264mm) | 36-1/4" (921mm) | 10-1/2" (267mm) |
| H10, V10 | 1000 | 472 | 48" (1219mm) | | 48-1/4" (1225mm) | |
| H13, V13 | 1250 | 590 | 60" (1524mm) | | 60-1/4" (1530mm) | |
| H15/H20, V15/V20 | 1500/ 2000 | 708 | 72" (1829mm) | | 72-1/4" (1835mm) | |

Figure 76: Louver with Flange (Horizontal Blades Shown)

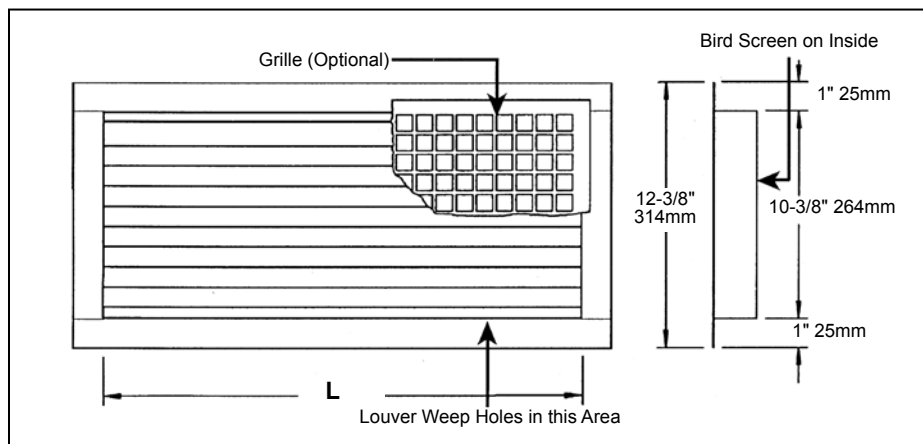
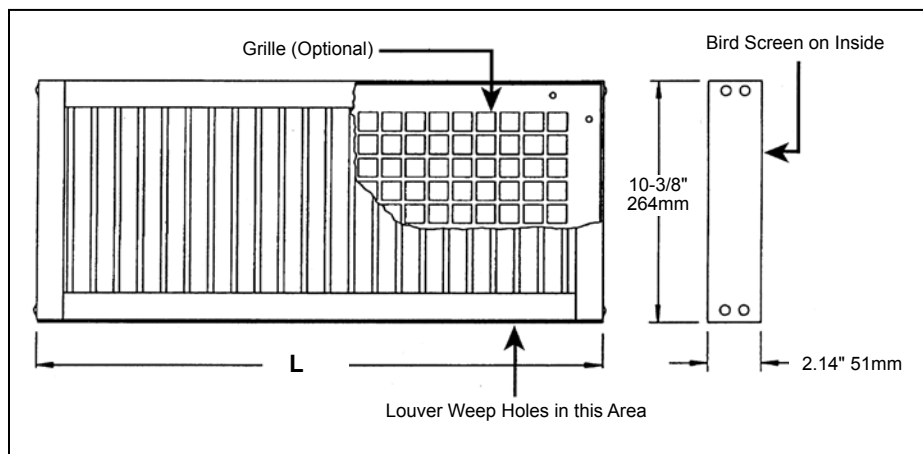

Figure 77: Louver without Flange (Vertical Blades Shown)



VentiMatic Shutter Assembly

- Notes:**
1. Horizontal blade louver shown. Vertical blade louver also available with VentiMatic shutter.
 2. Optional exterior grille matches unit ventilator louver in material and design. Mounted in wall louver.
 3. Optional interior grille mounting hardware is not included.
 4. Louver leaves seal against plate to prevent air infiltration.

Figure 78: VentiMatic Shutter Assembly with Optional Grille

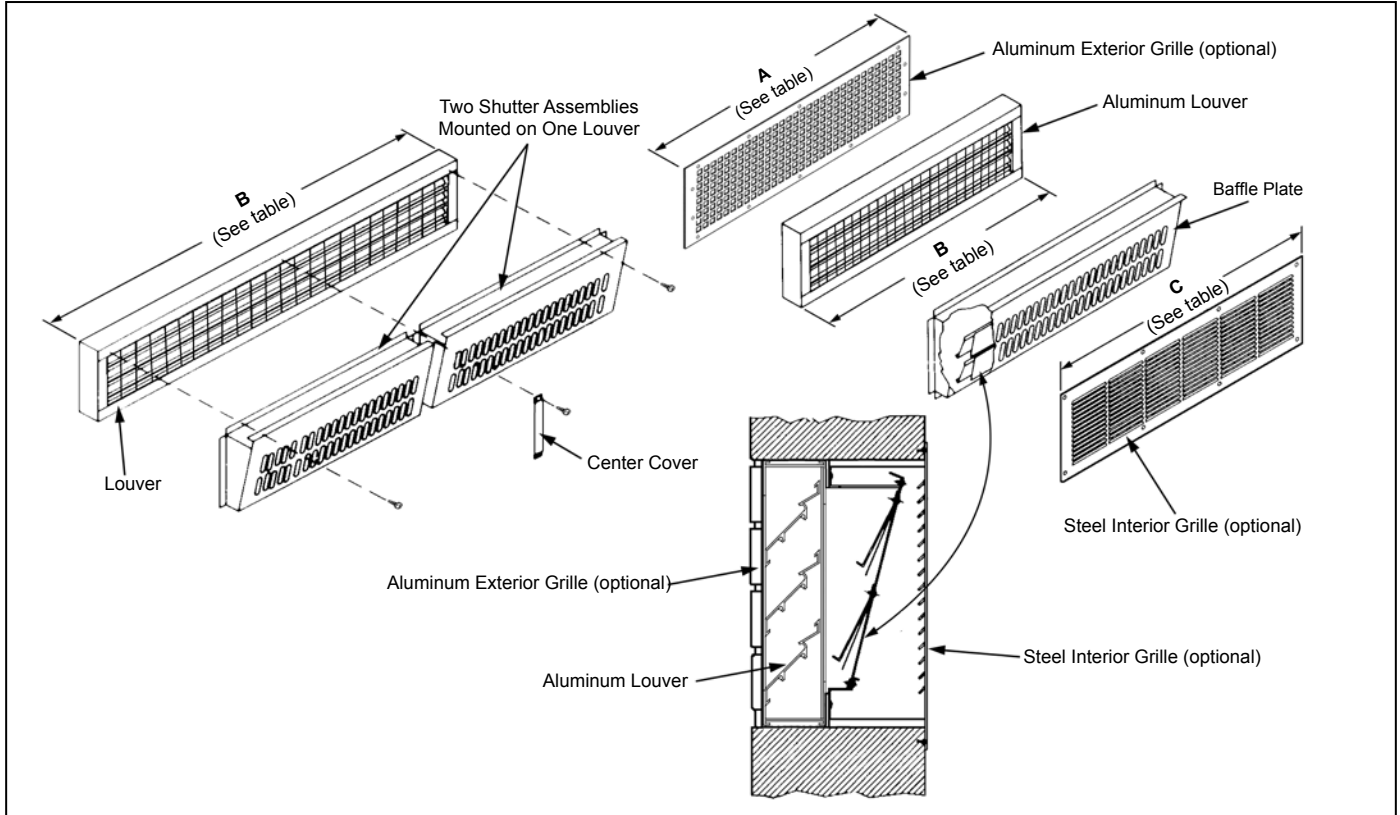

Table 29: Recommended Wall Openings and Max Air Capacities for VentiMatic Shutter Assembly

| Exterior Grille Width | | Louver Width | | Interior Grille Width | | Recommended Wall Opening For Louver | | | | Max Number of VentiMatic Shutters To Mount On Standard Louver | | VentiMatic Shutter(s) Max Air Capacity | |
|-----------------------|------|--------------|------|-----------------------|------|-------------------------------------|------|--------|-----|---|---------------------|--|-----|
| A | | B | | C | | Length | | Width | | 24" (610mm) Shutter | 36" (914mm) Shutter | CFM | L/s |
| inches | mm | inches | mm | inches | mm | inches | mm | inches | mm | | | | |
| 23-3/4 | 603 | 24 | 610 | 27 | 686 | 24-1/4 | 616 | 10-1/2 | 267 | 1 | 0 | 500 | 236 |
| 36-3/4 | 933 | 36 | 914 | 39 | 991 | 36-1/4 | 921 | | | 0 | 1 | 750 | 354 |
| 47-3/4 | 1213 | 48 | 1219 | 51 | 1295 | 48-1/4 | 1225 | | | 2 | 0 | 1000 | 472 |
| 59-3/4 | 1518 | 60 | 1524 | 63 | 1600 | 60-1/4 | 1530 | | | 1 | 1 | 1250 | 590 |
| 71-3/4 | 1822 | 72 | 1829 | 75 | 1905 | 72-1/4 | 1835 | | | 0 | 2 | 1500 | 708 |

Quick Selection Procedure

The following procedure will provide you with a rough determination of unit capacity for cooling and/or heating based on the number of coil rows. Use capacity tables for final selection. Consult your local Daikin representative for details on the computer selection programs Daikin Applied provides for this purpose.

Step 1: Determine Design Conditions

Determine design indoor and outdoor air temperatures in accordance with established engineering practices, as outlined in the ASHRAE Guide or other authoritative source. Indoor temperatures of 80°F dry bulb, 67°F wet bulb for summer and 70°F dry bulb for winter usually are acceptable for design or peak load conditions, even though the expected operating conditions of the system may be somewhat different.

Table 30: Chilled Water Cooling Capacity Btuh

| 80/67°F Entering Air Temperature; 45°F Entering Water Temperature; 10°F Water Temperature Rise | | | | | |
|--|---------|----------|----------|----------|----------|
| Rows | 750 cfm | 1000 cfm | 1250 cfm | 1500 cfm | 2000 cfm |
| 2 | 15,700 | 23,600 | 31,500 | 38,700 | 45,800 |
| 3 | 19,000 | 33,200 | 41,000 | 51,200 | 62,300 |
| 4 | 24,500 | 35,600 | 43,300 | 56,700 | 71,600 |
| 5 | 30,800 | 35,900 | 47,200 | 57,600 | 87,600 |

Table 31: Hot Water Heating Capacity Btuh

| 60°F Entering Air Temperature; 160°F Entering Water Temperature; 6 Gpm Water Flow | | | | | |
|---|---------|----------|----------|----------|----------|
| Rows | 750 cfm | 1000 cfm | 1250 cfm | 1500 cfm | 2000 cfm |
| 1 | 37,000 | 49,500 | 57,000 | 66,000 | 74,200 |
| 2 | 48,300 | 62,000 | 74,100 | 97,200 | 111,500 |
| 3 | 56,800 | 72,000 | 84,500 | 97,500 | 111,900 |
| 4* | 62,500 | 81,000 | 95,000 | 110,000 | 126,900 |

Note: *4-row coil only available with 2-pipe CW/HW system. HW will be piped for counter-flow

Table 32: Steam Heating Capacity Btuh

| 0°F Entering Air Temperature; 2 PSI Steam at 218.5°F | | |
|--|---------|---------|
| 750 cfm | Std Cap | 50,300 |
| | Hi Cap | 66,500 |
| 1000 cfm | Std Cap | 75,200 |
| | Hi Cap | 89,900 |
| 1250 cfm | Std Cap | 89,000 |
| | Hi Cap | 112,500 |
| 1500 cfm | Std Cap | 111,500 |
| | Hi Cap | 128,500 |
| 2000 cfm | Std Cap | 130,700 |
| | Hi Cap | 154,000 |

Step 2: Determine Heating and Cooling Loads

Calculate design winter heating losses and summer cooling loads in accordance with the procedures outlined by the ASHRAE Guide or other authoritative source. Perhaps the greatest consideration in calculating design loads is solar heat gain. August solar heat values might be used for summer cooling loads, but should not be used for ventilation air or “natural cooling” capacity calculations; since these cooling loads reach their maximum in the spring and autumn months. The natural cooling capacity is usually calculated for 55° or 60°F outdoor air temperature (see Table 34).

Table 34: Outdoor Air Ventilation Sensible Cooling Capacities Based On 75°F Room Temperature

| Unit Series | Nominal CFM | Outdoor Air Temperature | |
|-------------|-------------|-------------------------|----------|
| | | 55°F | 60°F |
| H07, V07 | 750 | 16.3 MBH | 12.2 MBH |
| H10, V10 | 1000 | 21.7 MBH | 16.3 MBH |
| H13, V13 | 1250 | 27.1 MBH | 20.3 MBH |
| H15, V15 | 1500 | 32.6 MBH | 24.4 MBH |
| H20, V20 | 2000 | 43.4 MBH | 32.5 MBH |

Step 3: Determine Air Quantity Required

Air quantity for heating applications is determined from circulation of a definite number of room air volumes per hour. Table 35 gives the recommended number of room air changes per hour.

Table 35: Recommended Room Air Changes Per Hour

| Type of Space | Recommended Number of Room Air Changes Per Hour |
|------------------------|---|
| Classrooms, Offices | 6 to 9 |
| Laboratories, Shops | 6 to 8 |
| Cafeterias, & Kitchens | 4-1/2 to 7 |

For rooms facing east, south or west, the higher values shown in the table should be used so adequate ventilation cooling will be available to prevent overheating during mild sunny weather. The following equation is helpful to determine the CFM air delivery for any given rate of circulation:

Equation 3: CFM For Given Rate Of Circulation

$$\frac{\text{Room Volume (cu ft)} \times \text{Room Changes per Hour}}{60} = \text{CFM}$$

In mechanical cooling applications, the total air quantity may be determined or verified by use of the sensible cooling load equation:

Equation 4: CFM Based On Sensible Cooling Load

$$\text{CFM} = \frac{Q \text{ sensible (space)}}{1.086 \times \text{TD}}$$

Q sensible is the maximum sensible room load and T.D. is the temperature difference between the room design dry bulb temperature and the final or leaving-air dry bulb temperature. For these calculations, a T.D. of 20°F is usually assumed to be desirable to avoid delivering air too cold for comfort. This figure may be varied one or two degrees for reasons of practicality.

Note: The sensible load used in the preceding equation is the space load and excludes the ventilation load.

Most areas have ventilation codes which govern the amount of ventilation air required for school applications. For other than school applications or areas not having codes, the ASHRAE Guide may be used for authoritative recommendations and discussion of the relation between odor control and outdoor air quantities.

The minimum outdoor air quantity recommended by ASHRAE for K-12 classrooms is 10 CFM per person plus 0.12 cfm/ft². Lower percent minimum outdoor air settings are more economical. In the interest of economy, it may be desirable to use lower percent minimums if there are no ventilation codes.

Step 4: Select Unit Size

The unit should be selected to meet or exceed the CFM delivery requirement previously determined. All model types are available with nominal capacities of 750, 1000, 1250, 1500 and 2000 CFM.

Heating Capacity

Unit heating capacity should be selected to equal or slightly exceed the computed room heat loss. For units installed for 100% recirculation, it is good practice to increase the heating capacity by 15% to aid in quick room warm-up. This allowance is unnecessary for units delivering a minimum outdoor air of 20% or more, since the outdoor air damper remains closed until the room is up to temperature. The heat normally expended in heating the minimum-percent outdoor air up to room temperature is available for quick warm-up purposes.

The heating required to warm the outdoor ventilating air up to room temperature must also be calculated. The Total Capacity should be used in sizing, piping, boilers, etc.

Cooling Capacity

Unit cooling capacity should be selected to equal or slightly exceed the sum of computed room sensible and latent

Step 5: Freeze Protection

Constant pump operation is required whenever the outdoor air temperature is below 35°F. This will assist in providing protection against freeze up of the system water piping and coils. To reduce the possibility of water coil freeze up on valve-controlled units, the valve must be selected properly to provide adequate water flow. See "Modulating Valve Sizing & Piping" on page 104. One of the steps below should be followed.

Chilled Water

Carry out one of the following steps to help protect against freezing:

- Drain the chilled water system during cold weather.
- Open the chilled water coil valves and operate the chilled water circulating pump any time the outside air temperature is below 35°F.
- Use antifreeze in the system.

Hot Water

Carry out one of the following steps to help protect against freezing:

- Use antifreeze in the system.
- Open the hot water coil valve and close the outdoor air damper whenever a freezing condition is sensed at the coil. Freezestat is factory-furnished on units with hydronic coils. (See page 91 through page 93 for details).

Step 6: Units With Antifreeze

If ethylene glycol or propylene glycol is used, its effect upon heating and cooling capacities and its effect on water pressure drops through the coil and piping system must be considered, as follows:

1. Divide the heating and/or cooling loads determined in Step 2 by the applicable capacity correction factor shown in Table 36 and Table 37 below to arrive at the calculated unit capacity required to take care of the capacity reduction caused by the glycol solution.

Table 36: Capacity Correction Factors for Ethylene Glycol

| Ethylene Glycol% Weight | 20% | 30% | 40% |
|-------------------------|------|------|------|
| Chilled Water | 0.92 | 0.84 | 0.75 |
| Hot Water | 0.94 | 0.90 | 0.84 |

Table 37: Capacity Correction Factors for Propylene Glycol

| Propylene Glycol% Weight | 20% | 30% | 40% |
|--------------------------|------|------|------|
| Chilled Water | 0.86 | 0.73 | 0.62 |
| Hot Water | 0.98 | 0.96 | 0.92 |

2. Determine the GPM required by entering the appropriate chilled water cooling capacity table or hot water capacity chart using the calculated unit capacity.
3. Determine the water pressure drop by multiplying the water pressure drop for the GPM determined above by the applicable pressure drop correction factor shown in Table 38 and Table 39 below.

Table 38: Pressure Drop Correction Factors for Ethylene Glycol

| Ethylene Glycol% Weight | 20% | 30% | 40% |
|-------------------------|------|------|------|
| Chilled Water | 1.15 | 1.22 | 1.34 |
| Hot Water | 1.08 | 1.11 | 1.19 |

Table 39: Pressure Drop Correction Factors for Propylene Glycol

| Propylene Glycol% Weight | 20% | 30% | 40% |
|--------------------------|------|------|------|
| Chilled Water | 1.24 | 1.27 | 1.35 |
| Hot Water | 1.07 | 1.11 | 1.15 |

Chilled Water Selection Example

Step 1: Determine Design Conditions

Assume the following design indoor and outdoor air temperatures are given:

- Outdoor design temperature = 96°F DB / 74°F WB
- Room design temperature = 76°F DB / 65°F WB

Step 2: Determine Cooling Loads

Assume the following cooling loads are given:

- Minimum total capacity (TC) = 43.4 MBH
- Minimum sensible capacity (SC) = 28.3 MBH
- Minimum outdoor air = 20%
- Room volume = 9,000 cubic feet
- Desired number of air changes per hour = 8
- Supply water temperature = 45°F EWT

Step 3: Determine Air Quantity Required

Equation 3 on page 56 indicates that to obtain eight room volumes per hour, a unit capable of delivering 1200 CFM standard air must be used, as follows:

$$\text{CFM} = \frac{(\text{Room Volume Ft}^3) \times (\text{Room Changes per Hour})}{80}$$

$$\text{CFM} = \frac{9000 \times 8}{60} = 1200$$

This indicates that an H13 Unit Ventilator should be used which delivers 1250 CFM.

Step 4: Select Unit Size

Determine the water flow (GPM), water temperature rise and the coil pressure drop as follows:

Determine Entering Dry Bulb Temperature

The entering dry bulb (EDB) temperature is calculated using the following formula:

$$\text{EDB} = \text{Room DB} \times \frac{\% \text{RA}}{100} + \text{Outdoor DB} \times \frac{\% \text{OA}}{100}$$

$$\text{EDB} = 76(0.8) + (96)(0.2) = 80^\circ\text{F}$$

Determine Entering Wet Bulb Temperature

The entering wet bulb (EWB) temperature is determined by calculating the Enthalpy (H) at saturation, then looking up the corresponding EWB ([Table 40 on page 54](#)). Enthalpy (H) is calculated as follows:

$$\text{Enthalpy (H)} = \text{Room Enthalpy} \times \frac{\% \text{RA}}{100} + \text{Outdoor Enthalpy} \times \frac{\% \text{OA}}{100}$$

$$\text{Enthalpy (H)} = 30.06 (0.8) + 37.66 (0.2) = 31.58 \text{ btu/lb}$$

Referring to [Table 40 on page 54](#), EWB for 31.58 btu/lb = 67°F

Look Up Capacities

Look up the Chilled Water Cooling Coil Capacity Table for our calculated values and cooling loads (ED-18517):

- Unit size: 1250 cfm
- Entering dry bulb (EDB) = 80
- Entering wet bulb (EWB) = 67°F
- Supply water temperature (EWT) = 45°F

Under these conditions, the 4-row coil produces:

- 43.4 MBH (TC)
- 28.3 MBH (SC)
- 8.8 GPM
- 6.7 ft. H₂O (WPD)
- 10°F (TR)

Leaving air temperatures dry bulb °F (LDB) and wet bulb °F (LWB) may be calculated as follows:

$$\text{LDB} = \text{EDB} - \frac{\text{SC(Btuh)}}{\text{CFM} \times 1.085} = 80 - \frac{28300}{1250 \times 1.085} = 59.1^\circ\text{F}$$

$$\text{LWBH} = \text{EWB} - \frac{\text{TC(Btuh)}}{\text{CFM} \times 4.5} = 31.62 - \frac{43400}{1250 \times 4.5} = 23.9$$

From [Table 40 on page 54](#):

LWB at 23.9 H = 56.1°F.

Note: *Interpolation within each table and between sets of tables for each unit series is permissible.*

For conditions of coil performance beyond the scope of the catalog selection procedures, Daikin offers computer selection programs for chilled water, hot water and steam coils. Consult your local Daikin representative for details.

Table 40: Enthalpy (H) at Saturation (But) Per Pound of Dry Air

| Wet Bulb Temp. °F | Tenths of A Degree | | | | | | | | | |
|-------------------|--------------------|-------|-------|-------|-------|-------|-------|-------|-------|-------|
| | 0 | 0.1 | 0.2 | 0.3 | 0.4 | 0.5 | 0.6 | 0.7 | 0.8 | 0.9 |
| 50 | 20.3 | 20.36 | 20.41 | 20.47 | 20.52 | 20.58 | 20.64 | 20.69 | 20.75 | 20.8 |
| 51 | 20.86 | 20.92 | 20.97 | 21.03 | 21.09 | 21.15 | 21.2 | 21.26 | 21.32 | 21.38 |
| 52 | 21.44 | 21.5 | 21.56 | 21.62 | 21.67 | 21.73 | 21.79 | 21.85 | 21.91 | 21.97 |
| 53 | 22.02 | 22.08 | 22.14 | 22.2 | 22.26 | 22.32 | 22.38 | 22.44 | 22.5 | 22.56 |
| 54 | 22.62 | 22.68 | 22.74 | 22.8 | 22.86 | 22.92 | 22.98 | 23.04 | 23.1 | 23.16 |
| 55 | 23.22 | 23.28 | 23.34 | 23.41 | 23.47 | 23.53 | 23.59 | 23.65 | 23.72 | 23.78 |
| 56 | 23.84 | 23.9 | 23.97 | 24.03 | 24.1 | 24.16 | 24.22 | 24.29 | 24.35 | 24.42 |
| 57 | 24.48 | 24.54 | 24.61 | 24.67 | 24.74 | 24.8 | 24.86 | 24.93 | 24.99 | 25.06 |
| 58 | 25.12 | 25.19 | 25.25 | 25.32 | 25.38 | 25.45 | 25.52 | 25.58 | 26.65 | 25.71 |
| 59 | 25.78 | 25.85 | 25.92 | 25.98 | 26.05 | 26.12 | 26.19 | 26.26 | 26.32 | 26.39 |
| 60 | 26.46 | 26.53 | 26.6 | 26.67 | 26.74 | 26.81 | 26.87 | 26.94 | 27.01 | 27.08 |
| 61 | 27.15 | 27.22 | 27.29 | 27.36 | 27.43 | 27.5 | 27.57 | 27.64 | 27.71 | 27.78 |
| 62 | 27.85 | 27.92 | 27.99 | 28.07 | 28.14 | 28.21 | 28.28 | 28.35 | 28.43 | 28.5 |
| 63 | 28.57 | 28.64 | 28.72 | 28.79 | 28.87 | 28.94 | 29.01 | 29.09 | 29.16 | 29.24 |
| 64 | 29.31 | 29.39 | 29.46 | 29.54 | 29.61 | 29.69 | 29.76 | 29.84 | 29.91 | 29.99 |
| 65 | 30.06 | 30.14 | 30.21 | 30.29 | 30.37 | 30.45 | 30.52 | 30.6 | 30.68 | 30.78 |
| 66 | 30.83 | 30.91 | 30.99 | 31.07 | 31.15 | 31.23 | 31.3 | 31.38 | 31.46 | 31.54 |
| 67 | 31.62 | 31.7 | 31.78 | 31.86 | 31.94 | 32.02 | 32.1 | 32.18 | 32.26 | 32.34 |
| 68 | 32.42 | 32.5 | 32.59 | 32.67 | 32.75 | 32.84 | 32.92 | 33 | 33.08 | 33.17 |
| 69 | 33.25 | 33.33 | 33.42 | 33.5 | 33.59 | 33.67 | 33.75 | 33.84 | 33.92 | 34.01 |
| 70 | 34.09 | 34.18 | 34.26 | 34.35 | 34.43 | 34.52 | 34.61 | 34.69 | 34.78 | 34.86 |
| 71 | 34.95 | 35.04 | 35.13 | 35.21 | 35.3 | 35.39 | 35.48 | 35.57 | 35.65 | 35.74 |
| 72 | 35.83 | 35.92 | 36.01 | 36.1 | 36.19 | 36.29 | 36.38 | 36.47 | 36.56 | 36.65 |
| 73 | 36.74 | 36.83 | 36.92 | 37.02 | 37.11 | 37.2 | 37.29 | 37.38 | 37.48 | 37.57 |
| 74 | 37.66 | 37.76 | 37.85 | 37.95 | 38.04 | 38.14 | 38.23 | 38.33 | 38.42 | 38.52 |
| 75 | 38.61 | 38.71 | 38.8 | 38.9 | 38.99 | 39.09 | 39.19 | 39.28 | 39.38 | 39.47 |
| 76 | 39.57 | 39.67 | 39.77 | 39.87 | 39.97 | 40.07 | 40.17 | 40.27 | 40.37 | 40.47 |
| 77 | 40.57 | 40.67 | 40.77 | 40.87 | 40.97 | 41.08 | 41.18 | 41.28 | 41.38 | 41.48 |
| 78 | 41.58 | 41.68 | 41.79 | 41.89 | 42 | 42.1 | 42.2 | 42.31 | 42.41 | 42.52 |
| 79 | 42.62 | 42.73 | 42.83 | 42.94 | 43.05 | 43.16 | 43.26 | 43.37 | 43.48 | 43.58 |
| 80 | 43.69 | 43.8 | 43.91 | 44.02 | 44.13 | 44.24 | 44.34 | 44.45 | 44.56 | 44.67 |
| 81 | 44.78 | 44.89 | 45 | 45.12 | 45.23 | 45.34 | 45.45 | 45.56 | 45.68 | 45.79 |
| 82 | 45.9 | 46.01 | 46.13 | 46.24 | 46.36 | 46.47 | 46.58 | 46.7 | 46.81 | 46.93 |
| 83 | 47.04 | 47.16 | 47.28 | 47.39 | 47.51 | 47.63 | 47.75 | 47.87 | 47.98 | 48.1 |
| 84 | 48.22 | 48.34 | 48.46 | 48.58 | 48.7 | 48.83 | 48.95 | 49.07 | 49.19 | 49.31 |
| 85 | 49.43 | 49.55 | 49.68 | 49.8 | 49.92 | 50.05 | 50.17 | 50.29 | 50.41 | 50.54 |

Hot Water Heating Selection

For proper temperature control, do not oversize the heating coil. Select the hot water coil that just slightly exceeds the required heating capacity. Hot water coils are offered in three capacities. The low-capacity (65) coil and the high-capacity (66) coil can be used as heating only or in conjunction with a chilled-water or direct expansion cooling coil. The 3-row hot water coil (67) can be used as a super-high-capacity hot water coil in applications that require high heating capacities, such as in extremely cold climates or when a high percentage of outdoor air is utilized.

A 4-row heating coil cannot be used in conjunction with a separate cooling (4-row) coil since there is only sufficient space in the unit to accommodate a total of 6 rows of coil. See "Available Coil Combinations" on page 20.

Quick Selection Method Using MBH/ΔT

Once the unit size has been selected, the MBH/ΔT factor can be utilized to quickly and accurately determine coil size and minimum GPM, where:

$$\Delta T = \text{Entering Water Temp} - \text{Entering Air Temp}$$

For example, assume an entering water temperature of 180°F, an entering air temperature of 55°F and a total heating load of 88 MBH. Then,

$$\Delta T = 180 - 55 = 125$$

and,

$$\text{MBH}/\Delta T = 88/125 = 0.7$$

Assume we want to size for the H13, 1250 cfm unit determined in the coil selection example previously given for cooling. Referring to Figure 79 on page 56 through Figure 82 on page 58:

1. Enter each chart at MBH/ΔT = 0.7.
2. Move horizontally to the right to intersect the unit 1250 curve.
3. Project downward for GPM requirement.

It is quickly seen that the 1-row coil (Figure 79 on page 56) does not meet the heating load. The 2-row coil (Figure 80 on page 57) can meet the requirement with 5.0 GPM. The 3-row coil (Figure 81 on page 57) is somewhat oversized.

Two-Pipe Chilled-Water/Hot-Water Applications

The foregoing selection procedures are for heating-only or for 4-pipe heating/cooling applications using separate heating and cooling coils.

In 2-pipe chilled-water/hot-water applications, the same coil is used for chilled water during the cooling season and for hot water during the heating season. In this case, the same GPM will be used for hot water as was

required for chilled water. It is necessary to determine only the supply water temperature required to satisfy the heating requirements. To do so:

1. Enter the appropriate chart at the known GPM.
2. Project upward to the size unit that is to be used.
3. Project a line horizontally across to obtain MBH/ΔT.
4. Divide the required MBH by the MBH/ΔT factor obtained from the chart.

This will give the required temperature difference between the supply water temperature and the entering air temperature. Supply water temperature can then be determined by adding the entering air temperature to this temperature difference.

Note: For 2-pipe chilled-water/hot-water coils, heating capacity is approximately 4 to 5% higher than that for standard capacity coils at the same GPM.

Table 41: Hot Water Coil Pressure Drop (Ft. H2O)

| Unit Size | Coil Rows | Water Flow (GPM) | | | | | | |
|--|------------|------------------|-----|------|------|------|------|------|
| | | 2 | 4 | 6 | 8 | 10 | 12 | 14 |
| H07, V07 750 cfm Nominal | 1 row coil | 0.6 | 2.5 | | | | | |
| | 2 row coil | 1.2 | 4.9 | 11.0 | 19.5 | | | |
| | 3 row coil | | 2.6 | 5.8 | 10.3 | 16.1 | | |
| | 4 row coil | | | 6.6 | 11.7 | 18.2 | 26.2 | |
| | 5 row coil | | | 7.2 | 12.1 | 18.1 | 25.1 | |
| H10, V10 1000 cfm Nominal | 1 row coil | 0.6 | 2.5 | 5.7 | | | | |
| | 2 row coil | | 3.4 | 7.7 | 13.7 | | | |
| | 3 row coil | | 2.9 | 6.4 | 11.4 | 17.8 | 25.7 | |
| | 4 row coil | | | 4.3 | 7.7 | 12.0 | 17.3 | 23.6 |
| | 5 row coil | | | 2.7 | 4.7 | 7.3 | 10.4 | 14.0 |
| H13, V13 1250 cfm Nominal | 1 row coil | 0.6 | 2.6 | 5.8 | 10.3 | | | |
| | 2 row coil | | 2.3 | 5.2 | 9.2 | | | |
| | 3 row coil | | | 2.9 | 5.1 | 7.9 | 11.4 | |
| | 4 row coil | | | 3.1 | 5.5 | 8.7 | 12.5 | 17.0 |
| | 5 row coil | | | 3.2 | 5.4 | 8.2 | 11.6 | 15.4 |
| H15, V15 1500 cfm Nominal | 1 row coil | 0.7 | 2.8 | 6.4 | 11.4 | | | |
| | 2 row coil | | 2.6 | 5.9 | 10.5 | | | |
| | 3 row coil | | | 3.3 | 5.9 | 9.2 | 13.2 | |
| | 4 row coil | | | 2.4 | 4.2 | 6.6 | 9.4 | 12.9 |
| | 5 row coil | | | 3.4 | 5.9 | 9.0 | 12.7 | 17.0 |
| H20, V20 2000 cfm Nominal | 1 row coil | 0.7 | 2.8 | 6.4 | 11.4 | | | |
| | 2 row coil | | 2.6 | 5.9 | 10.5 | | | |
| | 3 row coil | | | 3.3 | 5.9 | 9.2 | 13.2 | |
| | 4 row coil | | | 2.4 | 4.2 | 6.6 | 9.4 | 12.9 |
| | 5 row coil | | | 3.4 | 5.9 | 9.0 | 12.7 | 17.0 |

Note: The 2 gpm shown for capacity data is minimum recommended. Less than 2 gpm results in laminar flow in which heat transfer is unstable and therefore unpredictable.

Two-Pipe Selection Example

In the example previously given for cooling, the required flow rate was 12.5 GPM for the 4 row coil in an H13 unit with 1250 cfm. If we assume a heating load of 74 MBH, we can determine the required temperature difference as follows:

- 1 Enter the 4-row table (Figure 82 on page 58) with 12.5 GPM.
- 2 Project up to the 1250 curve.
- 3 Project horizontally to the left to determine the MBH/ ΔT factor of about 1.03.
- 4 Divide the required MBH (74) by the MBH/ ΔT factor obtained (1.03) from the chart. The resulting temperature difference is 70.

With a room design temperature of 70°F and assuming 20% outdoor air, the entering air temperature would be:
 $0 (.20) + 70 (.80) = 56^\circ\text{F}$

Therefore, the required supply water temperature would be: $70^\circ\text{F} + 56^\circ\text{F} = 126^\circ\text{F}$

Note: The 4 row coil has a very high heating capacity since it is sized for air conditioning. For this reason, a low entering water temperature will usually satisfy the heating requirements. This temperature may be too low for other equipment (such as radiation or convectors) in the system. It is important that supply water temperature be kept as close to that required by the unit ventilator as possible. Higher than required water temperature can result in poor temperature control resulting in overheating.

Figure 79: 1-Row Hot Water Coil

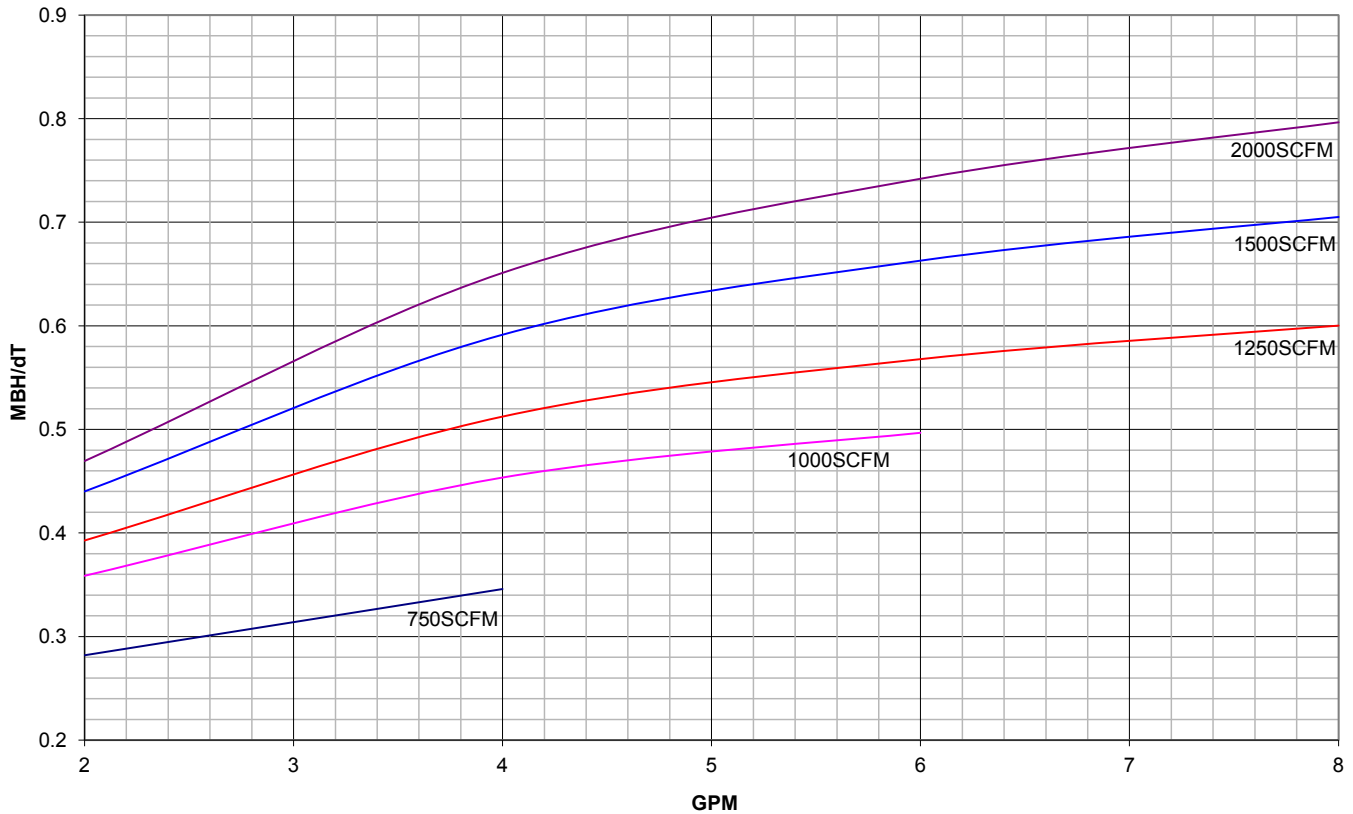
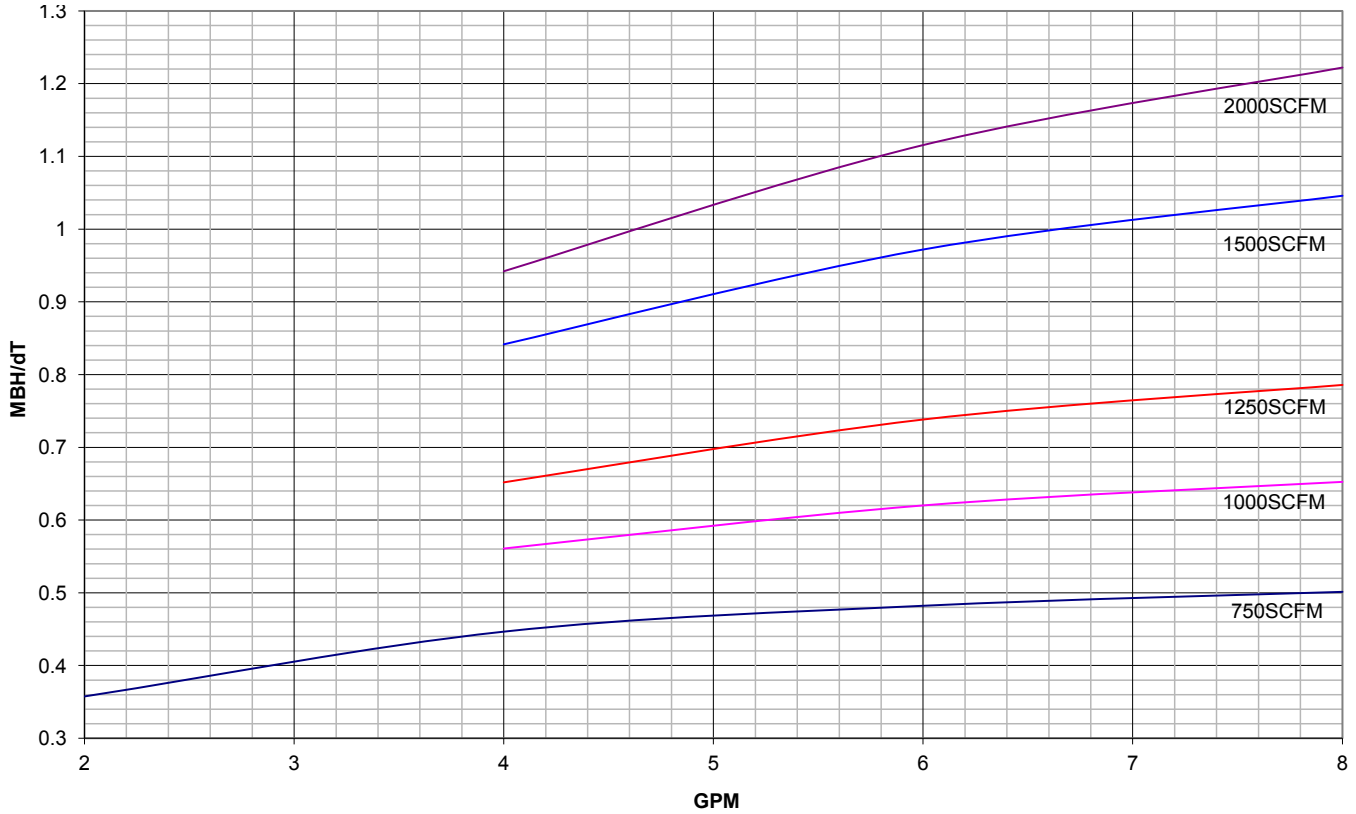
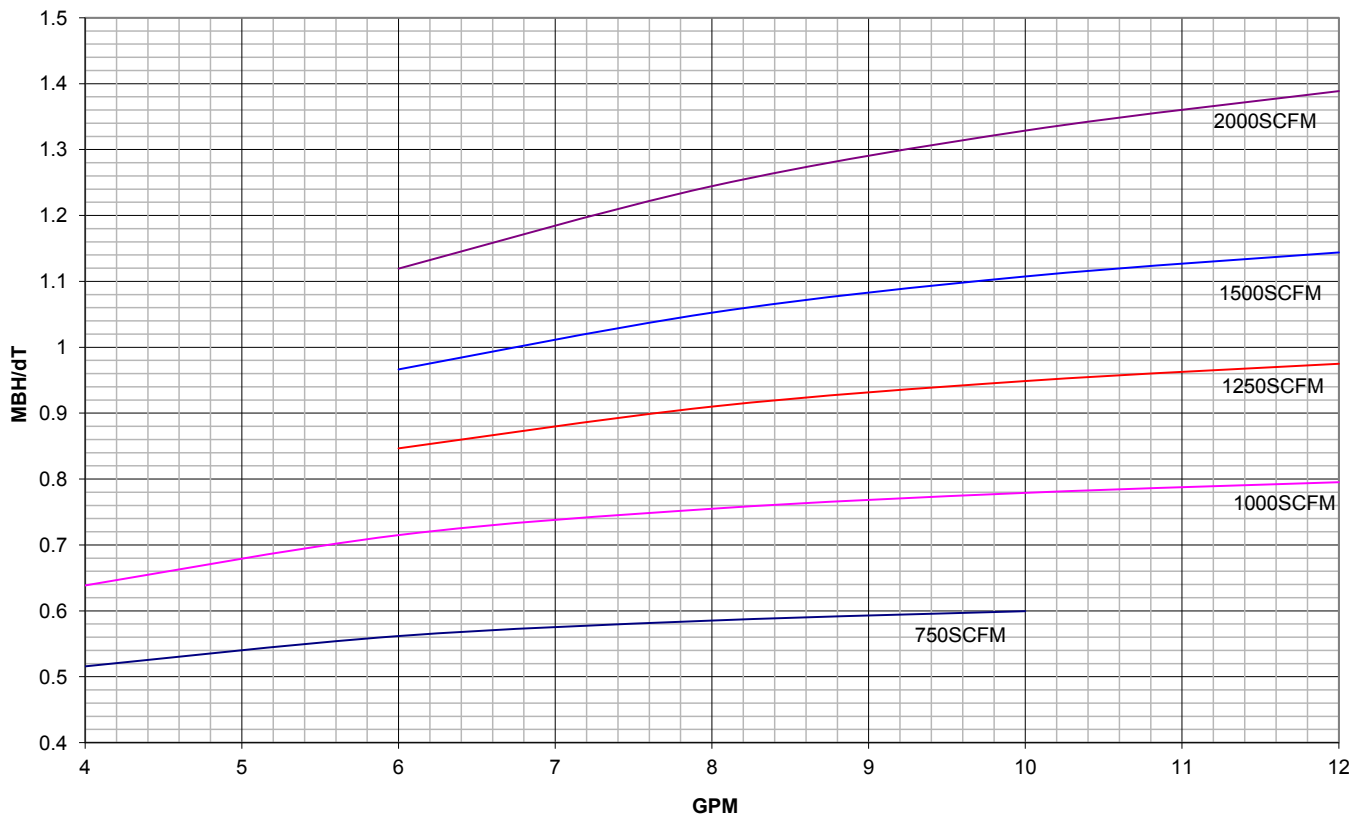

Figure 80: 2-Row Hot Water Coil (Parallel Flow)



Note: For 2-pipe CW/HW coils, heating capacity is approximately 4 to 5% higher for standard capacity coils at the same GPM.

Figure 81: 3-Row Hot Water Coil (Parallel Flow)



Note: For 2-pipe CW/HW coils, heating capacity is approximately 4 to 5% higher for standard capacity coils at the same GPM.

Figure 82: 4-Row, 2-Pipe Cold Water/Hot Water Coil (Counter Flow)

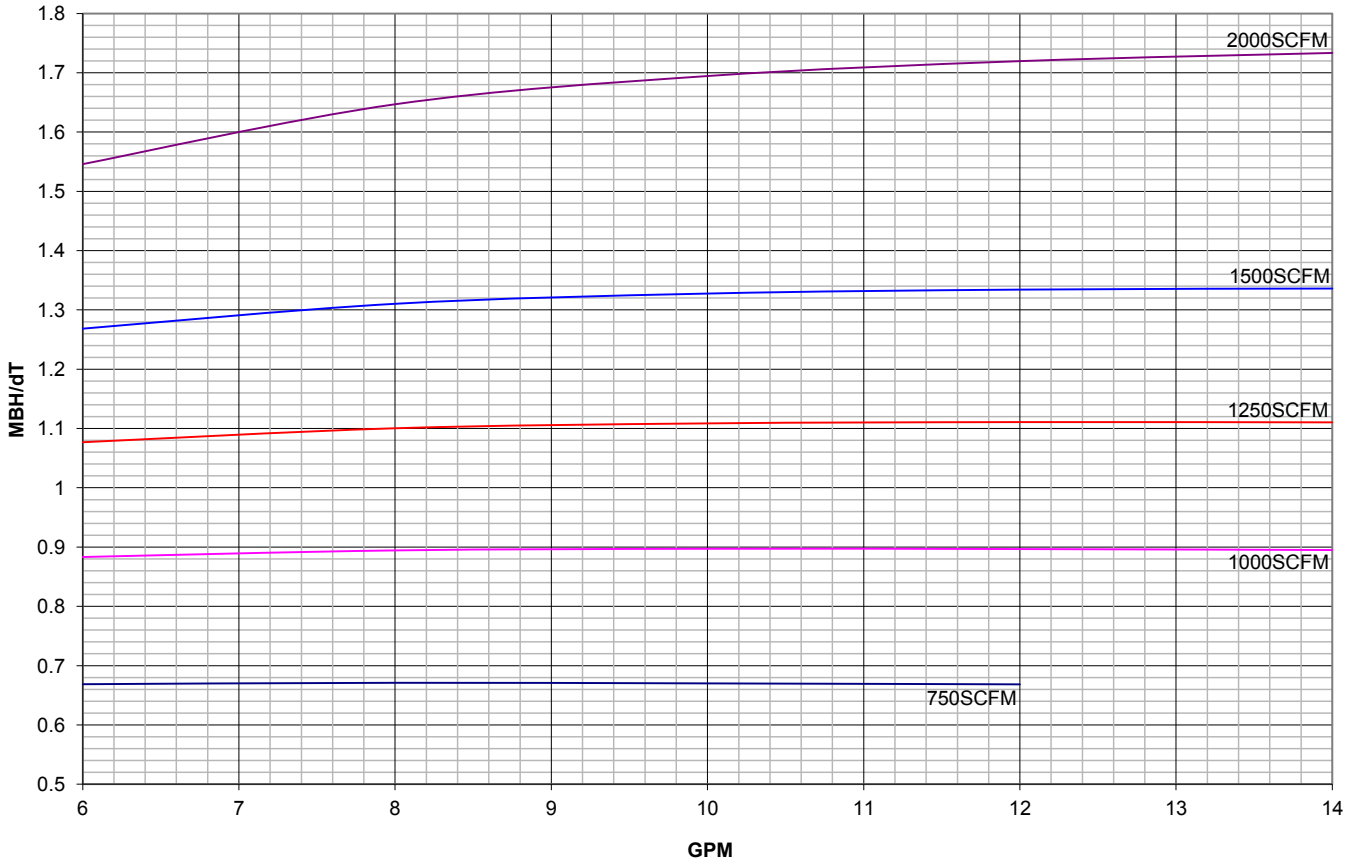

Steam Heating Selection

The maximum allowable steam pressure, especially in public buildings, is often fixed by state or local boiler codes. Steam Capacity in Table 42 is based on steam supply pressure of 2 PSI gauge and steam temperature of 218.5°F.

To determine total capacity for conditions other than shown in the Steam Capacity, multiply the total capacity given by the proper constant from the Steam Capacity Correction Factor in Table 43.

Maximum steam pressure is 15 PSIG at coil inlet.

Traps are by others. Either float and thermostatic traps or thermostatic traps may be used.

Table 42: Steam Heating Capacities - 2# Steam Coils¹

| Unit | Coil Capacity | Airflow SCFM | Entering Air Temperature °F | | | | | | | | | | | | | | | | | | | |
|------|---------------|--------------|-----------------------------|---------|-------|---------|-------|---------|-------|---------|-------|---------|-------|---------|-------|---------|-------|---------|-------|---------|-------|---------|
| | | | -20 | | -10 | | 0 | | 10 | | 20 | | 30 | | 40 | | 50 | | 60 | | 70 | |
| | | | MBH | LAT, db | MBH | LAT, db | MBH | LAT, db | MBH | LAT, db | MBH | LAT, db | MBH | LAT, db | MBH | LAT, db | MBH | LAT, db | MBH | LAT, db | MBH | LAT, db |
| 750 | Std | 750 | 55.1 | 47.8 | 52.7 | 54.9 | 50.3 | 61.8 | 47.8 | 68.8 | 45.3 | 75.7 | 42.7 | 82.6 | 40.0 | 89.2 | 37.3 | 95.9 | 35.6 | 103.8 | 32.9 | 110.5 |
| | High | | 73.0 | 69.8 | 69.8 | 75.8 | 66.5 | 81.8 | 63.2 | 87.7 | 59.8 | 93.5 | 56.4 | 99.3 | 52.7 | 104.8 | 49.1 | 110.4 | 45.4 | 115.8 | 41.6 | 121.1 |
| 1000 | Std | 1000 | 82.1 | 55.8 | 78.7 | 62.6 | 75.2 | 69.3 | 71.6 | 76.0 | 68.0 | 82.7 | 65.6 | 90.5 | 61.8 | 97.0 | 58.0 | 103.5 | 54.1 | 109.9 | 50.4 | 116.5 |
| | High | | 98.3 | 70.6 | 94.1 | 76.8 | 89.9 | 82.9 | 85.6 | 89.0 | 81.3 | 95.0 | 77.0 | 101.0 | 72.3 | 106.7 | 67.7 | 112.4 | 63.0 | 118.1 | 58.4 | 123.9 |
| 1250 | Std | 1250 | 97.0 | 51.6 | 93.0 | 58.6 | 89.0 | 65.7 | 85.0 | 72.7 | 80.9 | 79.7 | 76.7 | 86.6 | 72.3 | 93.3 | 67.9 | 100.1 | 63.5 | 106.9 | 59.9 | 114.2 |
| | High | | 122.6 | 70.4 | 117.6 | 76.7 | 112.5 | 83.0 | 107.3 | 89.2 | 102.1 | 95.3 | 96.8 | 101.4 | 91.2 | 107.3 | 85.6 | 113.2 | 80.0 | 119.0 | 74.4 | 124.9 |
| 1500 | Std | 1500 | 121.3 | 54.6 | 116.5 | 61.6 | 111.5 | 68.5 | 106.5 | 75.5 | 101.4 | 82.3 | 96.3 | 89.2 | 90.8 | 95.8 | 85.5 | 102.5 | 80.0 | 109.2 | 75.6 | 116.5 |
| | High | | 140.0 | 66.0 | 134.3 | 72.5 | 128.5 | 79.0 | 123.6 | 86.0 | 117.7 | 92.4 | 111.8 | 98.7 | 105.5 | 104.8 | 99.2 | 111.0 | 92.8 | 117.1 | 86.6 | 123.2 |
| 2000 | Std | 2000 | 142.3 | 45.6 | 136.5 | 52.9 | 130.7 | 60.3 | 124.8 | 67.5 | 118.9 | 74.8 | 112.8 | 82.0 | 106.6 | 89.1 | 100.3 | 96.3 | 94.0 | 103.3 | 87.5 | 110.4 |
| | High | | 167.8 | 57.3 | 160.9 | 64.2 | 154.0 | 71.0 | 146.9 | 77.7 | 139.8 | 84.5 | 133.7 | 91.6 | 126.4 | 98.3 | 119.0 | 104.9 | 111.5 | 111.4 | 103.8 | 117.9 |

¹ Data based on 2 psig steam pressure @ 10°F superheat steam vapor.

Table 43: Steam Capacity Correction Factors

| Steam Pressure PSIG | Entering Air Temperature Mixture, °F | | | | | | | | | |
|---------------------|--------------------------------------|------|------|------|------|------|------|------|------|------|
| | -20 | -10 | 0 | 10 | 20 | 30 | 40 | 50 | 60 | 70 |
| 0 | 0.97 | 0.97 | 0.97 | 0.96 | 0.97 | 0.97 | 0.97 | 0.96 | 0.96 | 0.96 |
| 2 | 1.00 | 1.00 | 1.00 | 1.00 | 1.00 | 1.00 | 1.00 | 1.00 | 1.00 | 1.00 |
| 5 | 1.02 | 1.03 | 1.03 | 1.03 | 1.04 | 1.05 | 1.05 | 1.05 | 1.05 | 1.05 |

Electric Heating Selection

Table 44: Electric Heat Capacities

| Unit Type | AHF AHV AHR | AHV AHR | AHF AHV AHR | AHV AHR | AHF AHV AHR | AHV AHR | AHF AHV AHR | AHV AHR | AHF AHV AHR | AHV AHR |
|--|-------------|---------|-------------|---------|-------------|---------|-------------|---------|-------------|---------|
| CFM | 750 (H07) | | 1000 (H10) | | 1250 (H13) | | 1500 (H15) | | 2000 (H20) | |
| Number of Electric Elements | 3 | 6 | 3 | 6 | 3 | 6 | 3 | 6 | 3 | 6 |
| 208 Volt Units | | | | | | | | | | |
| KW | 6.0 | 12.0 | 8.0 | 16.0 | 10.0 | 20.0 | 12.0 | 24.0 | 12.0 | 24.0 |
| MBH | 20.5 | 41 | 27.3 | 54.6 | 34.1 | 68.3 | 41 | 81.9 | 41 | 81.9 |
| Final Air Temp °F (70°F entering air temp) | 95.2 | 120.3 | 95.2 | 120.3 | 95.2 | 120.3 | 95.2 | 120.3 | 89.0 | 107.9 |
| Air Temperature Rise | 25.2 | 50.3 | 25.2 | 50.3 | 25.2 | 50.3 | 25.2 | 50.3 | 19.0 | 37.9 |
| 230, 265 or 460 Volt Units | | | | | | | | | | |
| KW | 5.5 | 11.0 | 7.4 | 14.7 | 9.2 | 18.4 | 11.0 | 22.0 | 11.0 | 22.0 |
| MBH | 18.8 | 37.5 | 25.3 | 50.2 | 31.4 | 62.8 | 37.5 | 75.1 | 37.5 | 75.1 |
| Final Air Temp °F (70°F entering air temp) | 93.2 | 116.2 | 93.2 | 116.2 | 93.2 | 116.2 | 93.2 | 116.2 | 87.4 | 104.8 |
| Air Temperature Rise | 23.2 | 46.2 | 23.2 | 46.2 | 23.2 | 46.2 | 23.2 | 46.2 | 17.4 | 34.8 |

Direct Expansion Cooling Coil Selection

Proper sizing of the field-supplied condensing units is important for trouble-free operation. An oversized condensing unit can reduce performance and cause operational problems such as:

- Compressor short cycling due to rapid pull down.
- Poor temperature and humidity control.
- Low saturated evaporator coil conditions.
- Low discharge air temperatures.

To properly size the unit ventilator, determine the cooling load based on May and September conditions at 1 pm when the classroom is occupied. Do not select units for July and August after 3 pm when the classroom is unoccupied. If the calculated cooling load falls between two unit sizes, select the smaller of the two units to minimize the potential problems seen with oversized units.

Figure 83 shows the total capacity of the unit ventilator versus saturated evaporator temperature. The condensing unit manufacturer’s capacity versus saturated suction temperature can be cross-plotted on this chart with an allowance for suction line loss. The total capacity and saturated suction temperature for the total system can be determined from this cross plot. The sensible capacity can be determined by multiplying the total capacity by the sensible heat factor shown in Table 45.

Table 45: Sensible Factor At 45°F Saturation Temperature

| 750 | 1000 | 1250 | 1500 | 2000 |
|------|------|------|------|------|
| 0.74 | 0.75 | 0.74 | 0.76 | 0.76 |

Figure 83: 2" DX Coil Estimated Performance (Mbh at 115°F Liquid Temperature)

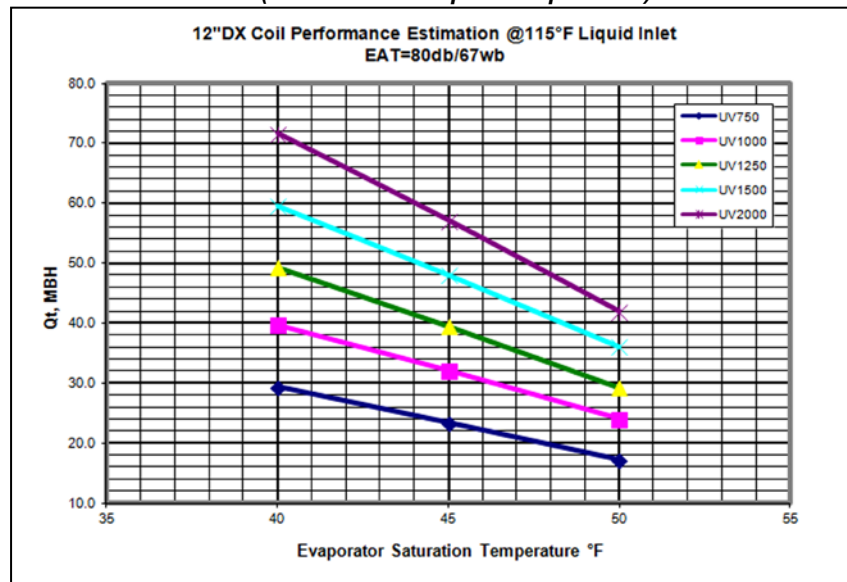
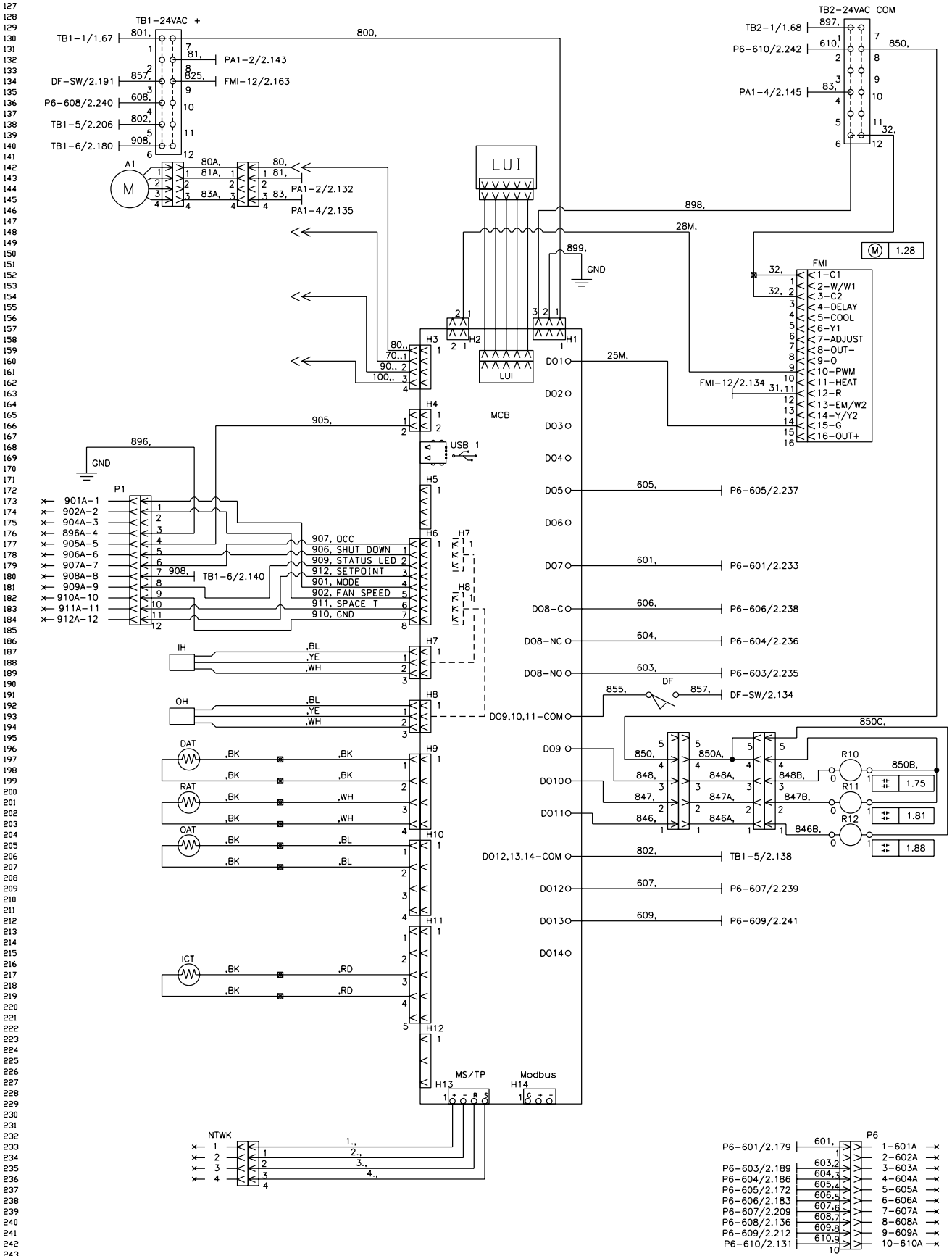

Table 46: Electrical Data

| | Unit Type | AHF | AHF | AHV | AHF | AHF | AHV | AHF | AHF | AHV | AHF | AHF | AHV | AHF | AHF | AHV |
|-----------------------|----------------------------------|-----------|-------|-------|------------|-------|-------|------------|-------|--------|------------|------|-------|------------|-------|--------|
| | | AHB | AHV | AHR | AHB | AHV | AHR | AHB | AHV | AHR | AHB | AHV | AHR | AHB | AHV | AHR |
| CFM | | 750 (H07) | | | 1000 (H10) | | | 1250 (H13) | | | 1500 (H15) | | | 2000 (H20) | | |
| Indoor Fan Motor HP | | 0.33 | | | 0.33 | | | 0.33 | | | 0.75 | | | 0.75 | | |
| # Elect Heat Elements | | — | 3 | 6 | — | 3 | 6 | — | 3 | 6 | — | 3 | 6 | — | 3 | 6 |
| 115-60-1 | Indoor Fan Motor Nameplate Amps | 5.0 | — | — | 5.0 | — | — | 5.0 | — | — | 9.6 | — | — | 9.6 | — | — |
| | Electric Heater Amps | — | — | — | — | — | — | — | — | — | — | — | — | — | — | — |
| | Unit MCA | 6.25 | — | — | 6.25 | — | — | 6.25 | — | — | 12 | — | — | 12 | — | — |
| | Max Fuse Size or Circuit Breaker | 15 | — | — | 15 | — | — | 15 | — | — | 15 | — | — | 15 | — | — |
| 208-60-1 | Indoor Fan Motor Nameplate Amps | 3.0 | 3.0 | 3.0 | 3.0 | 3.0 | 3.0 | 3.0 | 3.0 | 3.0 | 7.3 | 7.3 | 3.0 | 7.3 | 7.3 | 7.3 |
| | Electric Heat KW | — | 6.0 | 12.0 | — | 8.0 | 16.0 | — | 10.0 | 20.0 | — | 12.0 | 24.0 | — | 12.0 | 24.0 |
| | Electric Heater Amps | — | 28.8 | 57.7 | — | 38.5 | 76.9 | — | 48.1 | 96.2 | — | 57.7 | 115.4 | — | 57.7 | 115.4 |
| | Unit MCA | 3.75 | 39.75 | 75.88 | 3.75 | 51.88 | 99.88 | 3.75 | 63.88 | 124.00 | 9.13 | 81.3 | 153.4 | 9.13 | 81.25 | 153.38 |
| | Max Fuse Size or Circuit Breaker | 15 | 40 | 80 | 15 | 60 | 100 | 15 | 70 | 125 | 15 | 90 | 175 | 15 | 90 | 175 |
| 230-60-1 | Indoor Fan Motor Nameplate Amps | 2.8 | 2.8 | 2.8 | 2.8 | 2.8 | 2.8 | 2.8 | 2.8 | 2.8 | 6.8 | 6.8 | 6.8 | 6.8 | 6.8 | 6.8 |
| | Electric Heat KW | — | 5.5 | 11.0 | — | 7.4 | 14.7 | — | 9.2 | 18.4 | — | 11.0 | 22.1 | — | 11.0 | 22.1 |
| | Electric Heater Amps | — | 25.0 | 50.0 | — | 33.3 | 66.7 | — | 41.7 | 83.3 | — | 50.0 | 100.0 | — | 50.0 | 100.0 |
| | Unit MCA | 3.5 | 34.75 | 66.00 | 3.50 | 45.13 | 86.88 | 3.50 | 55.59 | 107.63 | 8.5 | 71 | 133.5 | 8.50 | 71.00 | 133.50 |
| | Max Fuse Size or Circuit Breaker | 15 | 35 | 70 | 15 | 50 | 90 | 15 | 60 | 110 | 15 | 80 | 150 | 15 | 80 | 150 |
| 265-60-1 | Indoor Fan Motor Nameplate Amps | 2.6 | 2.6 | 2.6 | 2.6 | 2.6 | 2.6 | 2.6 | 2.6 | 2.6 | 5.5 | 5.5 | 5.5 | 5.5 | 5.5 | 5.5 |
| | Electric Heat KW | — | 5.5 | 11.0 | — | 7.4 | 14.7 | — | 9.2 | 18.4 | — | 11.0 | 22.1 | — | 11.0 | 22.1 |
| | Electric Heater Amps | — | 21.7 | 43.3 | — | 28.9 | 57.8 | — | 36.1 | 72.2 | — | 43.3 | 86.6 | — | 43.3 | 86.6 |
| | Unit MCA | 3.25 | 30.38 | 57.38 | 3.25 | 39.38 | 75.50 | 3.25 | 48.38 | 93.50 | 6.88 | 61 | 115.1 | 6.88 | 61.00 | 115.13 |
| | Max Fuse Size or Circuit Breaker | 15 | 35 | 60 | 15 | 40 | 80 | 15 | 50 | 100 | 15 | 70 | 125 | 15 | 70 | 125 |
| 208-60-3 | Indoor Fan Motor Nameplate Amps | — | 3.0 | 3.0 | — | 3.0 | 3.0 | — | 3.0 | 3.0 | — | 7.3 | 7.3 | — | 7.3 | 7.3 |
| | Electric Heat KW | — | 6.0 | 12.0 | — | 8.0 | 16.0 | — | 10.0 | 20.0 | — | 12.0 | 24.0 | — | 12.0 | 24.0 |
| | Electric Heater Amps | — | 16.7 | 33.3 | — | 22.2 | 44.4 | — | 27.8 | 55.5 | — | 33.3 | 66.7 | — | 33.3 | 66.7 |
| | Unit MCA | — | 24.63 | 45.38 | — | 31.50 | 59.25 | — | 38.50 | 73.13 | — | 50.8 | 92.5 | — | 50.75 | 92.50 |
| | Max Fuse Size or Circuit Breaker | — | 25 | 50 | — | 35 | 60 | — | 40 | 80 | — | 60 | 100 | — | 60 | 100 |
| 230-60-3 | Indoor Fan Motor Nameplate Amps | — | 2.8 | 2.8 | — | 2.8 | 2.8 | — | 2.8 | 2.8 | — | 6.8 | 6.8 | — | 6.8 | 6.8 |
| | Electric Heat KW | — | 5.5 | 11.0 | — | 7.4 | 14.7 | — | 9.2 | 18.4 | — | 11.0 | 22.1 | — | 11.0 | 22.1 |
| | Electric Heater Amps | — | 14.5 | 28.9 | — | 19.3 | 38.5 | — | 24.1 | 48.2 | — | 28.9 | 57.8 | — | 28.9 | 57.8 |
| | Unit MCA | — | 21.63 | 39.63 | — | 27.63 | 51.63 | — | 33.63 | 63.75 | — | 44.6 | 80.75 | — | 44.63 | 80.75 |
| | Max Fuse Size or Circuit Breaker | — | 25 | 40 | — | 30 | 60 | — | 35 | 70 | — | 45 | 90 | — | 45 | 90 |
| 460-60-3 | Indoor Fan Motor Amps* | — | 5.0 | 5.0 | — | 5.0 | 5.0 | — | 5.0 | 5.0 | — | 9.6 | 9.6 | — | 9.6 | 9.6 |
| | Electric Heat KW | — | 5.5 | 11.0 | — | 7.4 | 14.7 | — | 9.2 | 18.4 | — | 11.0 | 22.1 | — | 11.0 | 22.1 |
| | Electric Heater Amps | — | 7.2 | 14.5 | — | 9.6 | 19.3 | — | 12.0 | 24.1 | — | 14.5 | 28.9 | — | 14.5 | 28.9 |
| | Unit MCA | — | 10.60 | 19.63 | — | 13.60 | 25.69 | — | 16.61 | 31.69 | — | 21.1 | 39.13 | — | 21.06 | 39.13 |
| | Max Fuse Size or Circuit Breaker | — | 15 | 20 | — | 15 | 30 | — | 20 | 35 | — | 25 | 40 | — | 25 | 40 |

* Fan Motor is 115/60/1

Figure 84: Typical MicroTech Wiring Diagram – 208V / 60Hz / 3Ph



Note: See Figure 85 on page 63 for typical MicroTech service and disconnect wiring and wiring schematic legend.

Figure 85: Typical MicroTech Wiring Diagram – Service and Disconnect – 208V / 60Hz / 3Ph

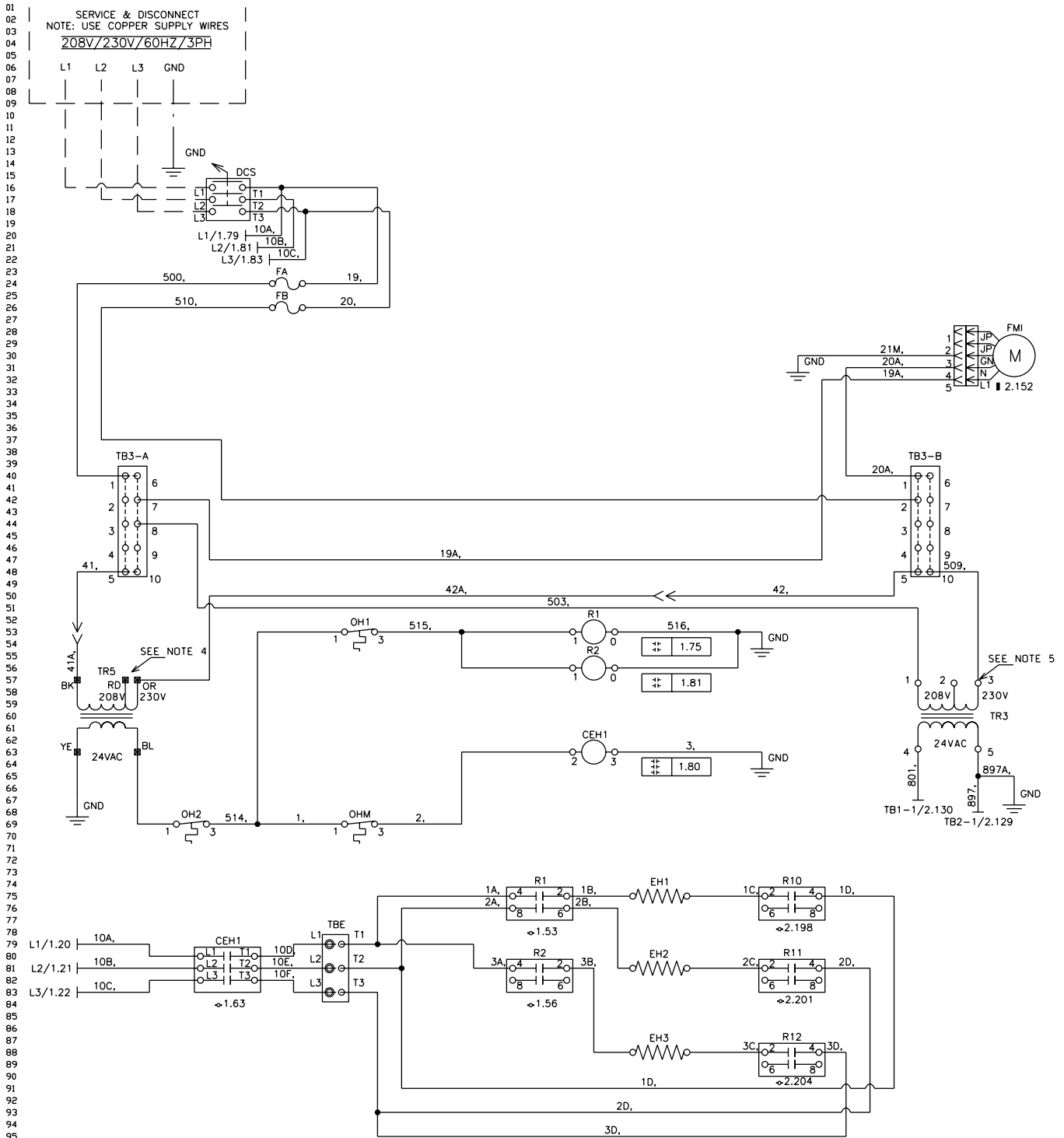

| Legend - Symbols | |
|------------------|--|
| --- | Accessory or field mounted component |
| | Ground |
| | Wire nut / splice |
| | Overlap point - common potential wires |
| L1/1.20 | Wire link (wire link ID / page # . line #) |

Table 47: Wiring Diagram Legend for Figure 84 on page 62 and Figure 85 on page 63

| Symbol | Description | Symbol | Description | Symbol | Description |
|---------|------------------------------------|---------|--------------------------------------|--------|------------------------------------|
| A1 | Actuator- Outdoor Air | HP | High Pressure Switch | R32 | Relay - Drain Pan Heater |
| A2 | Actuator- Face & Bypass | ICT | Sensor - Indoor DX Coil Temperature | R28 | Relay - Outdoor Motor Air |
| CP1 | Motor Compressor 2-Stage | IH | Sensor - Indoor Humidity | RV | Reversing Valve |
| C1 | Compressor Contactor | MCB | Main Control Board | RAT | Sensor - Room Air Temperature |
| CAP1 | Capacitor Run | NTWK | Network Connection | T6 | Thermostat - Freeze Stat |
| CEH1-3 | Electric Heat Contactor | OAT | Sensor - Outdoor Air Temperature | TB1 | Terminal Block - 24VAC+ |
| CO2 | Sensor - Indoor Air CO2 | OCT | Sensor - Outdoor DX Coil Temperature | TB2 | Terminal Block – 24VAC Gnd |
| DAT | Sensor - Discharge Air Temperature | OH | Sensor - Outdoor Humidity | TB3 | (A, B) Terminal Block – Main Power |
| DCS | Switch - Unit Power | OH1 | Thermostat - Overheat | TBE | Terminal Block - Electric Heat |
| DF | Dead Front Switch | OH2 | Thermostat - Overheat | TR1 | Transformer - Motor Speed |
| EH1-6 | Heater - Electric | OHM | E.H. Man Reset - Overheat Stat | TR3 | Transformer - 208 / 230V-24V, 75VA |
| EH10 | Heater - Outdoor Drain Pan | PL1 | LED Occupancy / Fault Status | TR4 | Transformer - 460V–230V |
| F1A/F1B | Fuse - Compressor | R1-R3 | Relay Electric Heat (Backup) | TR5 | Transformer - 208 / 230V-24V |
| F2A/F3C | Fuse - Electric Heat | R10-R12 | Relay - Electric Heat | V1 | Valve - Heat EOC (Accessory) |
| FA/FB | Fuse– Control, Load | R4H | Relay – Fan High Speed | V2 | Valve - Cool EOC (Accessory) |
| FC/FD | Fuse– Control, Transformer | R4M | Relay– Fan Medium Speed | VH | Valve - Heat (Accessory) |
| FMI | Motor - Room Fan | R4L | Relay– Fan Low Speed | VC | Valve - Cool (Accessory) |
| FMO | Motor Outdoor Air | | | | |

- Notes:**
1. All electrical installation must be in accordance with national and local electrical codes and job wiring schematic.
 2. External wiring options - see IM for the different configured options, wiring to be minimum 18 gauge, 90°C.
 3. EC motors are factory programmed for specified air flow. Contact Daikin Applied for replacement.
 4. Cap extra wire. Switch wire 42A to red wire for 208V operation.
 5. Switch wire 509 to terminal 2 for 208V operation.
 6. Devices in legend may or may not be on unit.

Typical Wall Sensors Diagram

Figure 86: Wall-Mounted Temperature Sensor Wiring

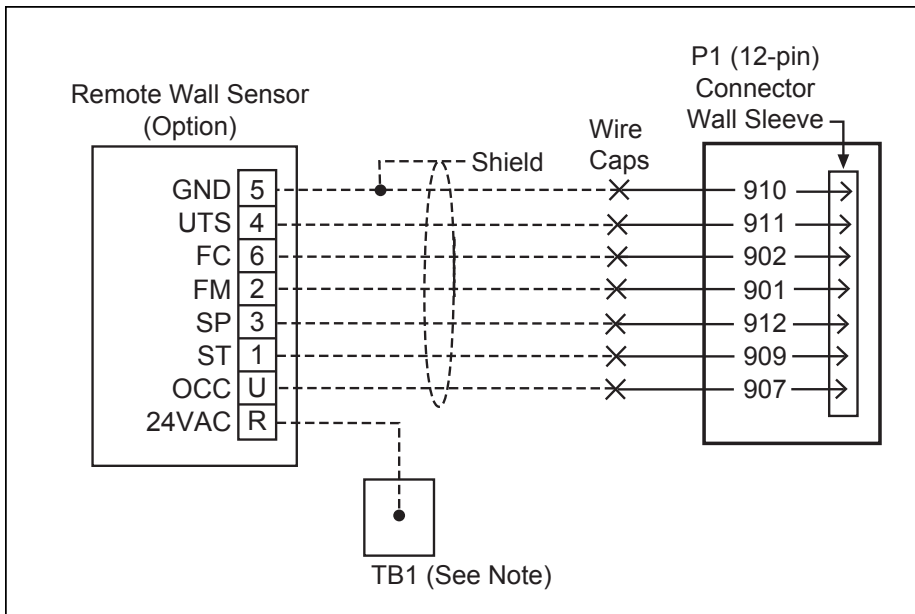

Power & Control Field Wiring

Figure 87: External Input Wiring Examples with or without Daisy Chaining of Units

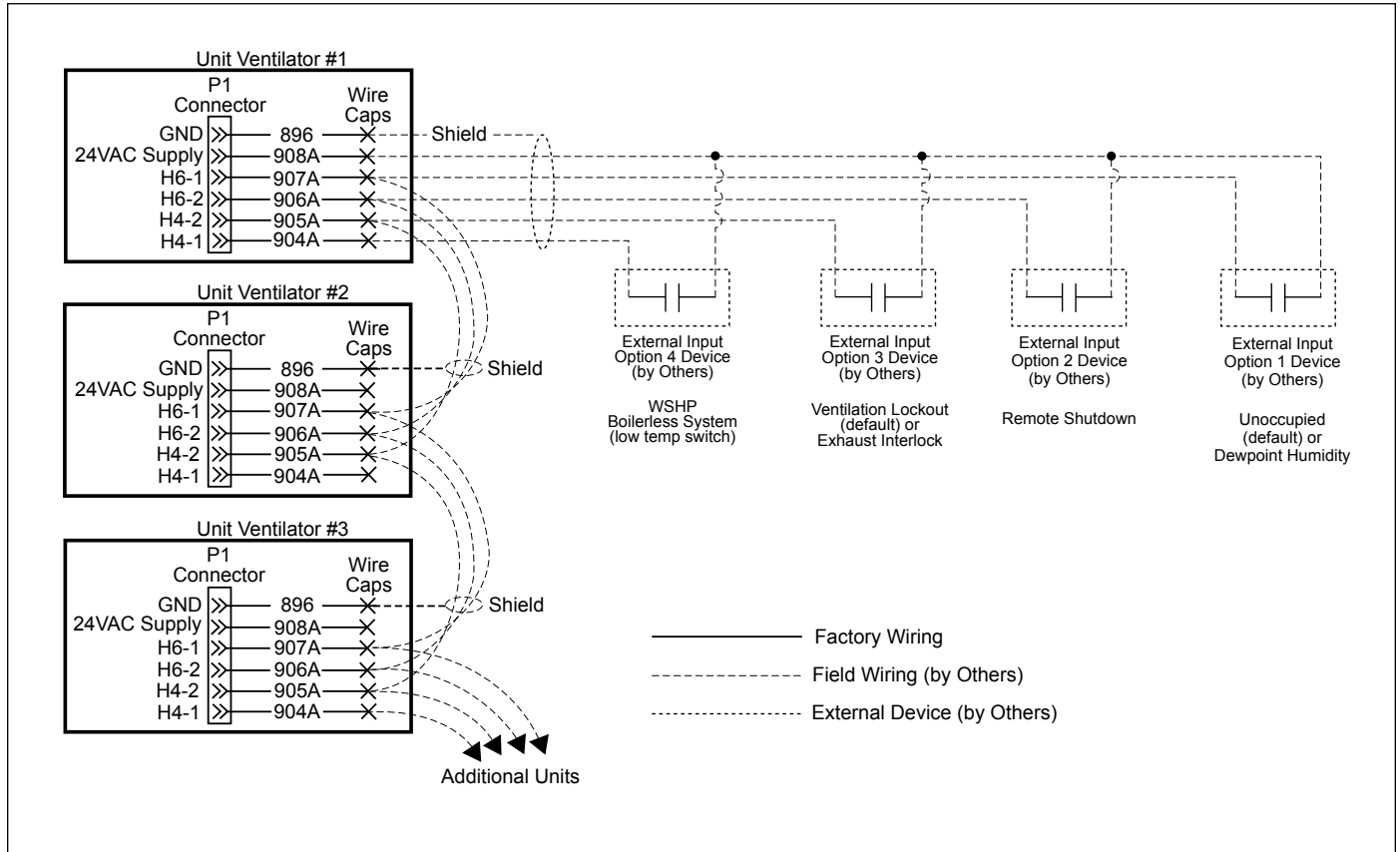

Figure 88: External Output Wiring - Single Unit

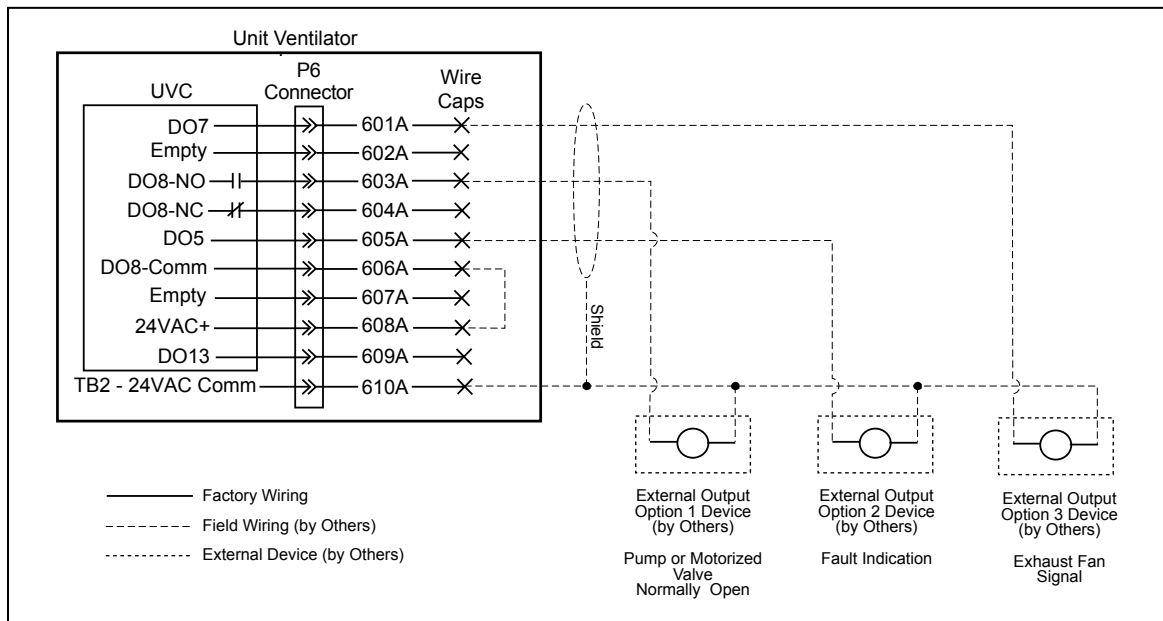

Figure 89: External Output Wiring - Multiple Units Shown

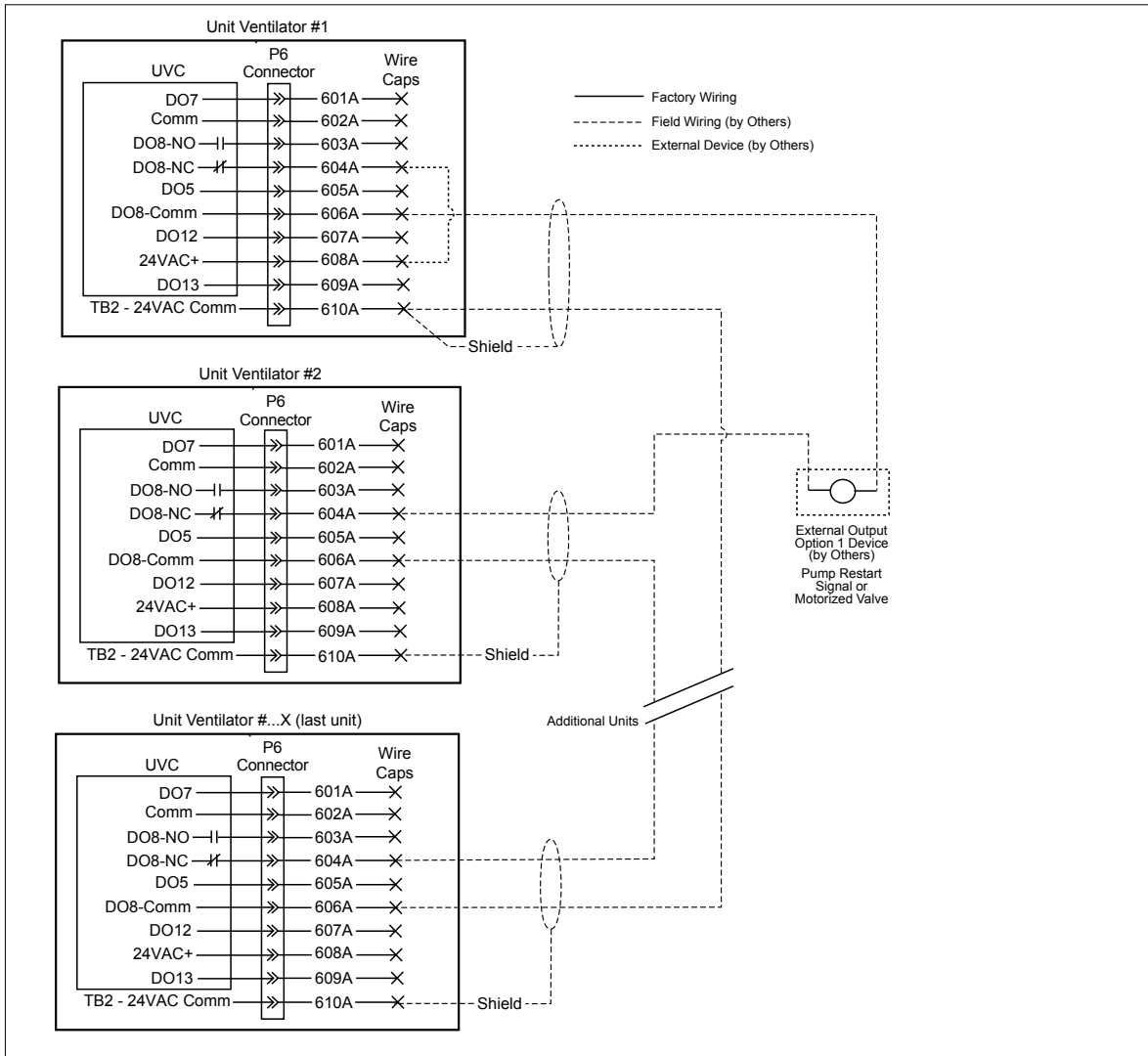
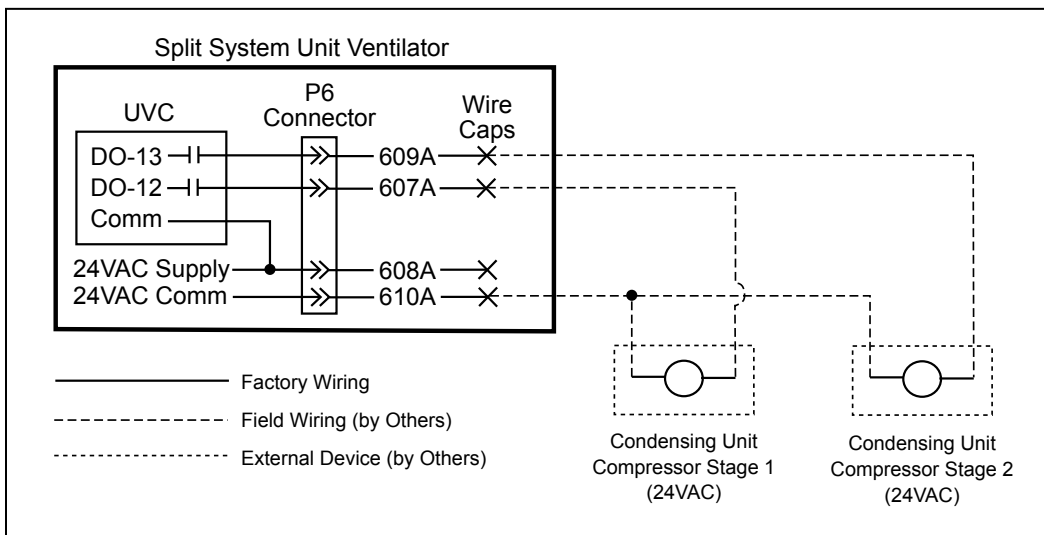
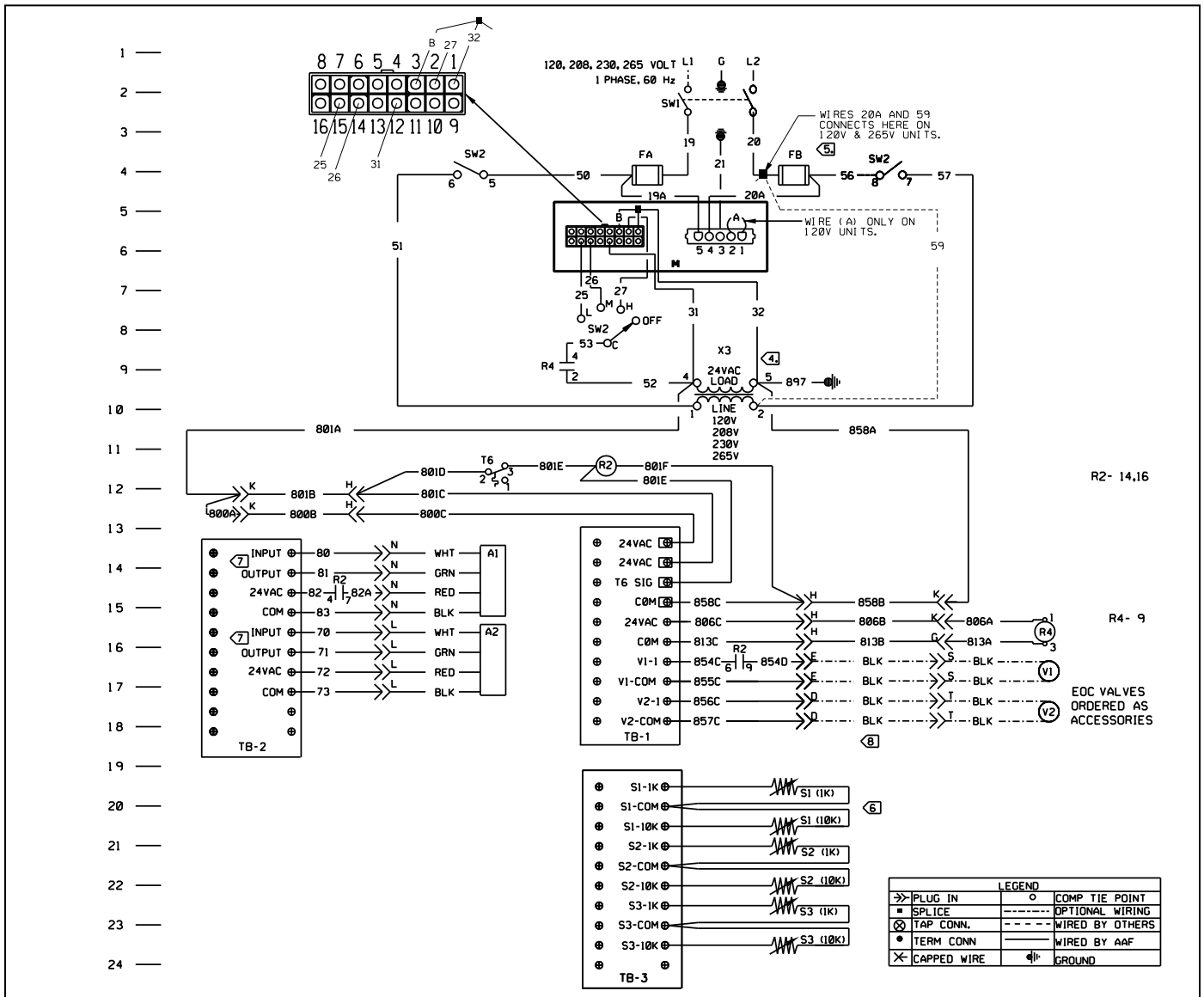

Figure 90: Split-System Condensing Unit Signal Wiring



Typical Digital Ready Wiring Diagram – 3-Speed EC Motor

Figure 91: Typical Digital Ready Wiring Diagram - Face & Bypass



| Symbol | Description | Line No. | Symbol | Description | Line No. |
|--------|--|----------|--------|------------------------------------|----------|
| A1 | Actuator - Outdoor Air/Return Air | 13 | SW1 | Switch - Disconnect | 2 |
| A2 | Actuator - Face & Bypass | 16 | SW2 | Switch - On-Off, Fan Speeds | 4 |
| FA/FB | Fuse - Control | 4 | TB-1 | Terminal Boards | 18 |
| M | Motor (ECM) - Fan, 1/3HP (750–1250), 3/4HP (1500–2000) | 5 | TB-2 | Terminal Boards | 18 |
| R2 | Relay - Actuator/Valve | 12 | TB-3 | Terminal Boards | 24 |
| R4 | Relay - Fan (Coil 24VAC) | 15 | T6 | Thermostat - Low Limit | 11 |
| S1 | Sensor - Room Air | 20 | v1 | Valve - Heating N.O. Spring Return | 17 |
| S2 | Sensor - Discharge Air | 21 | v2 | Valve - Cooling N.C. Spring Return | 18 |
| S3 | Sensor - Outdoor Air | 23 | x3 | Transformer 75VA Class 2 | 8 |

- Notes:**
- All electrical installation must be in accordance with national and local electrical codes and job wiring schematic.
 - Automatic temperature control supplier is responsible to ensure controls operate correctly and protect the unit.
 - Cap all unused transformer leads.
 - x3 unused terminal (2) or (3) must be insulated.
 - Fuse FB, wire 56 & 57 furnished on 208/230 volt units only.
 - 1K thermistor is positive temperature coefficient, 10K thermistor is negative temperature coefficient.
 - Actuators, 24VAC for 2 to 10 VDC control input, for a 4 to 20 mA input control signal..., add a 500 Ohm resistor across Wht and Blk output signal of 2 to 10 VDC for position feedback.
 - Cord furnished on right hand connections.
 - Motors are factory programmed for specified air flow, contact Daikin Applied for replacement.

Typical Controls By Others Wiring Diagram – Units with 3-Speed ECM

Figure 92: Typical Wiring Diagram 3-Speed ECM - Motor Switchbox, Non-Electric Heat Units

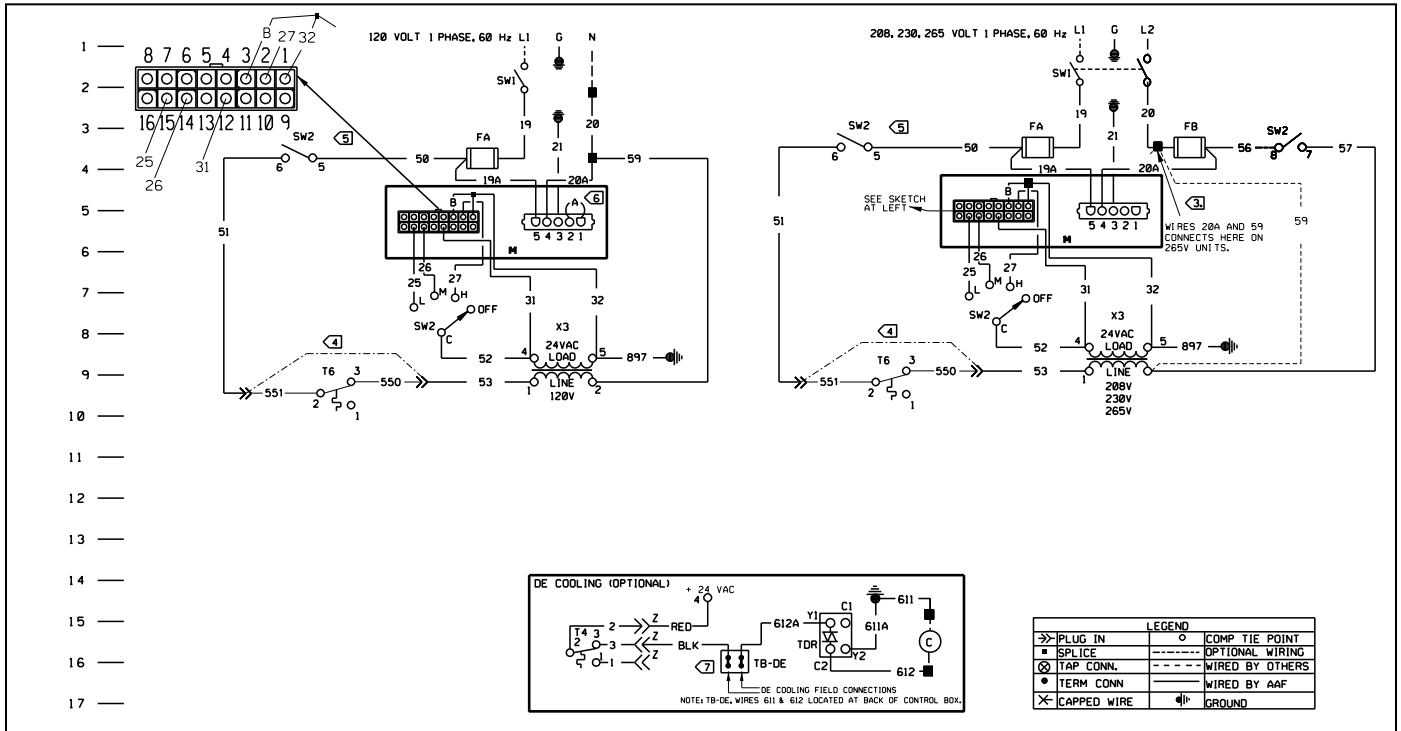

| Symbol | Description | Line No. | Symbol | Description | Line No. |
|--------|-----------------------------------|----------|--------|------------------------------------|----------|
| C | Contactor, Compressor (By Others) | 16 | T4 | Thermostat - DE Coil Low Limit 30° | 15 |
| FA/FB | Fuse - Control | 4 | T6 | Thermostat - Coil Low Temp 38° | 9 |
| M | Motor - Fan | 6 | TB-DE | Terminal Board for DE Contactor | 16 |
| SW1 | Switch - Disconnect | 2 | TDR | Time Delay (Low Volts) 5 Min | 15 |
| SW2 | Switch - On-Off, Fan Speeds | 4, 8 | x3 | Transformer 75VA Class 2 | 8 |

- Notes:**
- All electrical installation must be in accordance with national and local electrical codes and job wiring schematic.
 - Cap all unused transformer leads.
 - Fuse FB, SW2, wire 56 & 57 furnished on 208/230 volt units only.
 - T6, wires 550 & 551 furnished only on units with hot water or chilled water, all others connect transformer wire to wire 501.
 - SW2 contacts 5, 6 and 7. **8 open only when SW2 is in OFF position.**
 - Jumper wire "A" must be connected to pins 1 & 2 for 120V only.
 - Automatic temperature control can be wired to TB-DE for DE cooling operation. Typical operation is to wire from the TB-DE, to a normally open relay with the relay closing on control call for cooling.
 - Motors are factory programmed for specified air flow, contact Daikin Applied for replacement.

Typical Controls By Others Wiring Diagram – Units with EC Motor Variable Airflow

Figure 93: Typical Wiring Diagram for Controls By Others - Variable Airflow ECM

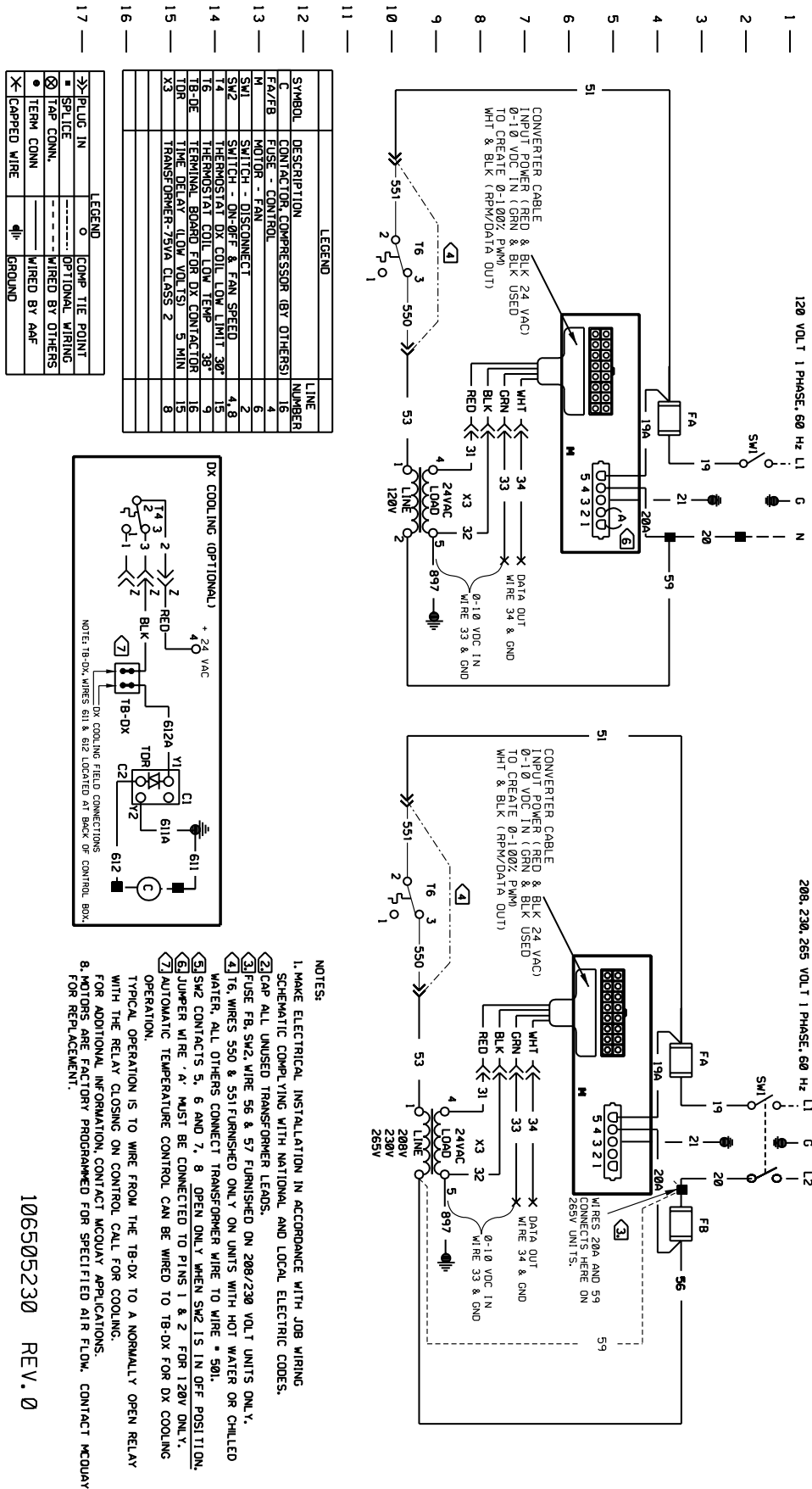

106505230 REV. 0

Control Modes and Functions

Daikin Applied unit ventilators equipped with MicroTech unit controllers can be programmed to operate in a variety of modes based on the current situation in the room and the status of the unit ventilator. Changes in mode can be triggered manually, via network signals, by sensor readings, or by date and time. External inputs and outputs can be used to change modes, communicate data to network controls or change the functional operation of the unit.

Occupancy Modes

MicroTech unit controllers can be set up to change modes based on room occupancy. Four different occupancy modes are provided, as described below.

Occupied Mode

This is the normal daytime operation mode. The controller maintains a room set point using the outside air capability and other functions.

Note: *For non-school applications, the unit can also be configured to cycle the fan in response to the room load. In this case, the fan would normally be in the Off Mode until heating or cooling is required. The outside air damper is always closed when the fan is off. When the fan starts, the outside air damper opens to the required position, usually minimum position.*

Unoccupied Mode

This is the night setback operating mode, in which the unit responds to a new room set point and cycles to maintain the condition. The fan comes on when heating or cooling is needed and runs until the load is satisfied. The outdoor air damper is closed during this mode. When a cooling load is satisfied by a refrigerant system, the compressor is de-energized and the unit ventilator indoor fan continues to run for a fixed period of time to remove coldness from the evaporator coil. This reduces the potential for low refrigerant temperatures to exist on the evaporator coil.

Stand By Mode

In this mode, the unit maintains the occupied mode set point temperature with the outdoor air damper closed. The fan runs continuously unless it is configured to cycle in response to the load.

Bypass Mode

This is a tenant override operating mode initiated by using the optional LUI or by depressing the Tenant Override Switch on the optional room sensor. The unit is placed back into Occupied Mode for a predetermined time (default 120 minutes). This time can be set in 1-minute increments from 1 minute to 240 minutes through the Unit Ventilator Service Tool or a network.

Economizer Modes

Economizer operation is facilitated by the outdoor air damper, which automatically adjusts the above-minimum outside air position to provide free cooling when the outdoor air temperature is appropriate. Three levels of economizer control are available:

Basic Economizer Operation: The MicroTech controller compares the inside and outside temperatures. If the temperature comparison is satisfactory, then free-air economizer operation is used to cool the space. Reheat units also come configured with an indoor humidity sensor.

Expanded Economizer Operation: In addition to comparing inside and outside temperatures, outdoor relative humidity is measured to calculate outside air enthalpy. If the enthalpy set point is not exceeded, and the temperature comparison is satisfactory, then free economizer operation is used to cool the space. This helps to minimize the entrance of humid outside air.

Leading-Edge Economizer Operation: The MicroTech controller compares both indoor and outdoor temperatures and indoor and outdoor relative humidities. Then it calculates both inside and outside air enthalpy to determine if free economizer operation can cool the space with non-humid outside air. This is a true enthalpy economizer—a first for unit ventilators.

Night Purge Mode

Under this mode, the unit is configured to purge the room space for one hour for various reasons (odor or fume removal, drying, etc.). During Night Purge the outside air damper is open full and the fan is run on high speed. No “normal” heating or cooling takes place (the emergency heat set point is maintained) and the exhaust fan, if the room is so equipped, is signaled to turn on.

Freeze Prevention Mode

This mode helps protect the unit ventilator from freezing air conditions. Control functions vary depending on the type of temperature control used by the unit, as follows:

Face and bypass control units: Upon sensing a potential freezing air temperature condition leaving the heating coil, the unit will automatically protect itself by shutting the outside air damper and opening the EOC valve. The face and bypass damper is allowed to operate normally to control the space. The fan continues to run to remove the cold air. Once accomplished, the freezestat is reset, the outside air damper opens to the minimum position and the unit commences its normal mode of operation.

Valve control units: Upon sensing a potential freezing air temperature condition leaving the heating coil, the unit will automatically protect itself by shutting the outside air damper and opening the hot water valve to a minimum of 50% (more if required to heat the room). The fan speed will be staged down to low speed and then turned off. When the freeze stat is reset, the outside air damper opens to the minimum position and the fan runs at low speed for a minimum of 10 minutes. It then will stage up if needed to satisfy the room set point. This reduces the potential to overheat a room recovering from a potential freeze condition.

Note: *Valve selection and coil sizing is critical for proper operation. Face and bypass control is recommended for proper humidity and freeze protection.*

Emergency Heat Mode

If the unit is left in a mode that does not normally allow heating (such as Off, Fan Only, Cool, or Night Purge) and the room temperature falls below 55°F, the unit will heat the space to above 55°F and then return to the previously set mode of operation. This mode of operation can be field configured and/or be disabled.

External Input Functions

The unit ventilator controller is provided with four (4) binary inputs that allow a single set of dry contacts to be used as a signal to it, and two (2) binary inputs that allow a 24VAC signal. Input signal choices are described below. Multiple units can be connected to a single set of dry contacts.

Note: *Not all of the functions listed can be used at the same time. The unit ventilator controller is provided with configuration parameters that can be adjusted to select which function will be used for these inputs where multiple functions are indicated below.*

Unoccupied Input Signal

This input signals the unit ventilator controller to go into unoccupied or occupied mode. When the contacts close, the unit ventilator controller goes into unoccupied mode; when the contacts open, it goes into occupied mode. Additional variables can affect occupancy mode and override this binary input. See "[Occupancy Modes](#)" on [page 70](#).

Dewpoint/Humidity Input Signal (Optional)

This input signals the unit ventilator controller to go into active dehumidification mode. When the contacts close (high humidity) the controller will go into active dehumidification; when the contacts open (low humidity) it will stop active dehumidification.

Remote Shutdown Input Signal

This input signals the unit ventilator controller to go into shutdown mode. When the contacts close, the controller goes into shutdown mode; when the contacts open, it returns to normal operation.

Ventilation Lockout Input Signal

This input signals the unit ventilator controller to close the outdoor air damper. When the contacts close (ventilation lockout signal) the controller closes the outdoor damper; when the contacts open, it returns to normal outdoor damper operation.

Exhaust Interlock Input Signal

This input signals the unit ventilator controller that an exhaust fan within the space has been energized. The controller then repositions the outdoor air damper to a user-adjustable minimum position. When the contacts close (exhaust fan on signal) the controller uses the value defined by the Exhaust Interlock OA Damper Min Position Setpoint as the new minimum outdoor air damper position regardless of the indoor air fan speed. When the contacts open, it returns to normal outdoor damper operation.

External Output Functions

The unit ventilator controller is provided with three (3) binary outputs to perform the functions described below. These are relay type outputs that supply 24VAC.

Note: *Not all of the functions listed can be used at the same time. The unit ventilator controller is provided with configuration parameters that can be adjusted to select which function will be used for these outputs when multiple functions are indicated below.*

Fault Signal

This relay output provides one set of Normally Open (NO) (reversible through keypad/software) 24VAC contacts that can be used to signal a fault condition. When a fault exists, the unit ventilator controller energizes this relay output. When the fault or faults are cleared, it de-energizes this relay output.

Exhaust Fan On/Off Signal

This relay output provides one set of Normally Open (NO) (reversible through keypad/software) 24VAC contacts that can be used to signal the operation of an exhaust fan. When the outdoor air damper opens more than the Energize Exhaust Fan OA Damper Setpoint, the relay output will signal the exhaust fan on (contacts closed). When the outdoor damper closes below this setpoint, the relay output will signal the exhaust fan off (contacts open).

Auxiliary Heat Signal

This relay output provides one set of Normally Open (NO) (reversible through keypad/software) 24VAC contacts that can be used to operate an auxiliary heat device. The unit ventilator controller by default is configured to operate a NO auxiliary heat device (de-energize when heat is required) such as a wet heat valve actuator with a spring setup to open upon power failure. However, the Auxiliary Heat Configuration variable can be used to set the controller to use an NC auxiliary heat device (energize when heat is required) such as electric heat.

Advanced Control Options

MicroTech controls make possible a number of advanced control options that can quickly pay for themselves in saved energy costs and more comfortable classrooms, as described below.

Part Load Variable Air Control

Part Load Variable Air control can be used in conjunction with face and bypass damper temperature control to automatically adjust the unit ventilator fan speed based upon the room load and the room-temperature PI control loop. This MicroTech control option provides higher latent cooling capabilities and quieter operation during non-peak load periods by basing indoor fan speed upon room load.

During low-load or normal operation (about 60% of the time) the fan will operate on low speed. When the load increases to an intermediate demand, the fan will automatically shift to the medium-speed setting. Under near-design or design-load conditions, the fan will operate on high speed. A built-in, 10-minute delay helps minimize awareness of fan speed changes. Low-speed fan operation under normal operating conditions, in conjunction with our GentleFlo fan technology contributes to a very quiet classroom environment.

Demand-Controlled Ventilation (Optional)

Daikin unit ventilators can be equipped to use input from a CO₂ controller to ventilate the space based on actual occupancy instead of a fixed design occupancy. This Demand Controlled Ventilation (DCV) system monitors the amount of CO₂ produced by students and teachers so that enough fresh outdoor air is introduced to maintain good air quality. The system is designed to achieve a target ventilation rate (e.g., 15 cfm/person) based on actual occupancy.

By using DCV to monitor the actual occupancy pattern in a room, the system can allow code-specific levels of outdoor air to be delivered when needed. Unnecessary over-ventilation is avoided during periods of low or intermittent occupancy.

With DCV you can be confident that your school is meeting ventilation standards for Indoor Air Quality and that your students are receiving adequate air to be attentive to instruction. At the same time, you are saving money in early morning hours, in between classes, or after hours when classrooms are heated and cooled but not always fully occupied.

As Simple as a Thermostat

Demand Controlled Ventilation is easy to apply. When DCV is ordered, a CO₂ sensor is mounted on the unit and configured for operation. The system does the rest. If desired, the ventilation control setpoint can be adjusted through the MicroTech Controller.

Acceptance By Codes And Standards

ASHRAE Standard 62-2004 Ventilation for Indoor Air Quality recognizes CO₂ based DCV as a means of controlling ventilation based on occupancy. The ASHRAE standard has been referenced or adopted by most regional and local building codes. This standard references ventilation on a per-person basis.

Using CO₂ control will sometimes lower the absolute amount of outside air delivered into a room but will maintain the per-person rate. For example, if a classroom is designed for 30 students, the ventilation rate is 450 cfm (30 students x 15 cfm/student). However, when there are only ten students in the classroom, the CO₂ control will adjust ventilation to 150 cfm (10 students x 15 cfm/student). A minimum base ventilation rate (typically 20% of design levels) is provided when in the occupied mode. This provides outdoor air to offset any interior source contamination while allowing for proper space pressurization.

Active Dehumidification Control (Reheat)

In high-humidity applications where valve-controlled, reheat units are used, the Active Dehumidification Control (ADC) sequence should be considered. During excessive humidity conditions, a humidity sensor directs the unit to continue cooling past the room setpoint to remove excess moisture. Hydronic heat or electric heat is then used to reheat the discharge air to maintain acceptable room temperatures.

MicroTech controls minimize the amount of reheat needed to maintain relative humidity below a preset limit. Reheat is used only when required and in the most energy-efficient manner possible.

Active Dehumidification comes standard on units equipped with MicroTech controls, a reheat configuration and valve-control temperature modulation. The MicroTech ADC humidity sensor is unit-mounted. It issues a signal proportional to the classroom's humidity level (unlike humidistats which issue an open-close signal). This enables a control sequence that manages both the temperature and the relative humidity.

When the relative humidity exceeds a preset value, the modulating chilled-water valve opens fully to dehumidify the mixture of outdoor and return air entering the cooling coil. The reheat modulating water valve then opens, or electric heat is engaged, to reheat the air leaving the cooling coil, as required to maintain the classroom setpoint.

Active dehumidification starts when the indoor relative humidity exceeds the preset relative humidity upper setpoint and continues until the room humidity falls 5% below the endpoint. During active dehumidification, economizer operation is disabled (and the outdoor air damper is reset to its minimum position) unless the outdoor air temperature is below 55°F. It is maintained until dehumidification is completed. When the indoor humidity level is satisfied, the MicroTech controller reverts to its normal sequences to satisfy the classroom temperature setpoint.

Passive Dehumidification Control

On units with face and bypass damper control, a chilled-water coil and MicroTech part-load variable air control, passive dehumidification can be used under high humidity conditions to keep classrooms comfortable. A unit-mounted humidity sensor and a low fan speed are utilized to improve latent cooling by keeping the air in closer contact with the cold coil for passive dehumidification.

This only occurs in the unoccupied mode as the unit operates to satisfy the humidity set point with the outside damper closed. The face and bypass damper is placed in a minimum face position to promote high latent cooling. The unit fan continues to operate on low speed until the load is satisfied. This is very helpful in high humidity areas where high night time humidity can be absorbed in the building during off hours.

DX Split System Control

On unit ventilators equipped with direct-expansion (DX) coils, the unit ventilator controller is configured to operate the compressor as secondary (mechanical) cooling when economizer cooling is available, and as primary cooling when economizer cooling is not available. Additional DX control features include:

Compressor Cooling Lockout: The unit ventilator controller is configured to lock out compressor cooling when the outdoor air temperature falls below the compressor cooling lock out setpoint. Below this temperature setpoint only economizer cooling will be available.

Minimum On And Off Time: The unit ventilator controller is provided with minimum-on and minimum-off timers to prevent adverse compressor cycling (3-minutes default).

Compressor Start Delay Variable: This variable is intended to be adjusted as part of the start-up procedure for each unit. It is used to prevent multiple unit compressors from starting at the same time after a power failure or after an unoccupied-to-occupied changeover. Each unit should be configured at start-up with a slightly different (random) delay, or groups of units should be provided with different delays.

System Components

The main components of the MicroTech system are:

- A Unit Ventilator Controller (UVC) with on-board BACnet MS/TP communications
- Optional Local User Interface (LUI)
- Optional Lon plug-in network communication module

In addition, unit ventilators equipped with MicroTech controllers feature factory-mounted sensors and actuators for system control and feedback.

Unit Ventilator Controller

The MicroTech UVC is a DDC, microprocessor-based controller designed to provide sophisticated comfort control of an economizer-equipped Daikin unit ventilator. In addition to normal operating control, it provides alarm monitoring and alarm-specific component shutdown if critical system conditions occur. Each UVC is factory wired, factory programmed and factory run-tested for the specific unit ventilator model and configuration ordered by the customer.

Figure 94: MicroTech Control Board

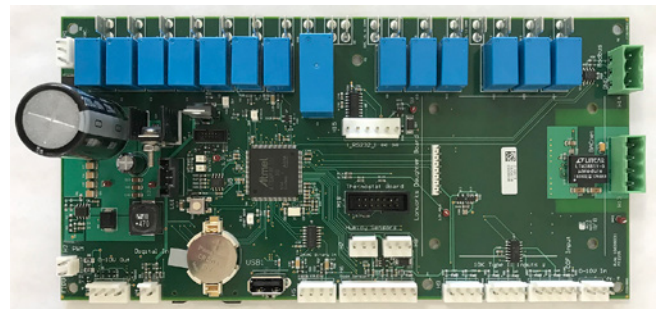

Local User Interface (Optional)

An optional LUI touch pad with digital LED Display is located in the right hand compartment below the top right access door. The LUI features a 4 x 20 OLED digital display, 4 keys, and 2 individual LED indicators. In addition to the Operating Mode States and Fan Functions, the Touch Pad will digitally display:

- The room set point temperature.
- The current room temperature.
- Any fault code for quick diagnostics at the unit.

Figure 95: User Interface Touch Pad



The User Interface has individual touch-sensitive printed circuit board mounted buttons, and comes with a built-in menu structure (Password Protected) to change many of the common operating variables.

Four Operating Mode States

Four different user operating mode states can be chosen on the LUI:

Heat: Heating and economizer operation only.

Cool: Cooling and economizer operation only.

Fan Only: Fan only operation.

Auto: The unit automatically switches between heating, cooling and economizer operation to satisfy the room load conditions. The current unit state is also displayed.

Four Fan States

Four fan states are provided on all units: high, medium low and Auto speed modulation. The Auto speed function (part load, variable air) varies the fan speed automatically to meet the room load whether the unit is in heating, cooling or economizer mode.

All this is accomplished with a standard, single-speed NEMA frame motor. A built-in 10-minute delay helps minimize awareness of speed changes. During low-load or normal operation (about 60% of the time) the fan will operate at low speed. The low speed operation, along with GentleFlo fan technology, contributes to a very quiet classroom environment.

When the load increases to an intermediate demand, the fan automatically shifts to the medium speed setting. At near-design or design-load conditions the fan will operate on high speed.

With four fan states and GentleFlo fan technology, there is no need to oversize units or worry about uncomfortable conditions.

Table 48: Ranges For 3 Speed Adjustable ECM Fan

| Fan Speed | Operating Range |
|------------------------|-----------------|
| PWM low fixed-speed | 50% - 80% |
| PWM medium fixed-speed | 70% - 90% |
| PWM high fixed-speed | 80% - 100% |

Note: Low speed ≤ medium speed ≤ high speed.

Figure 96: MicroTech Sensor and Component Locations

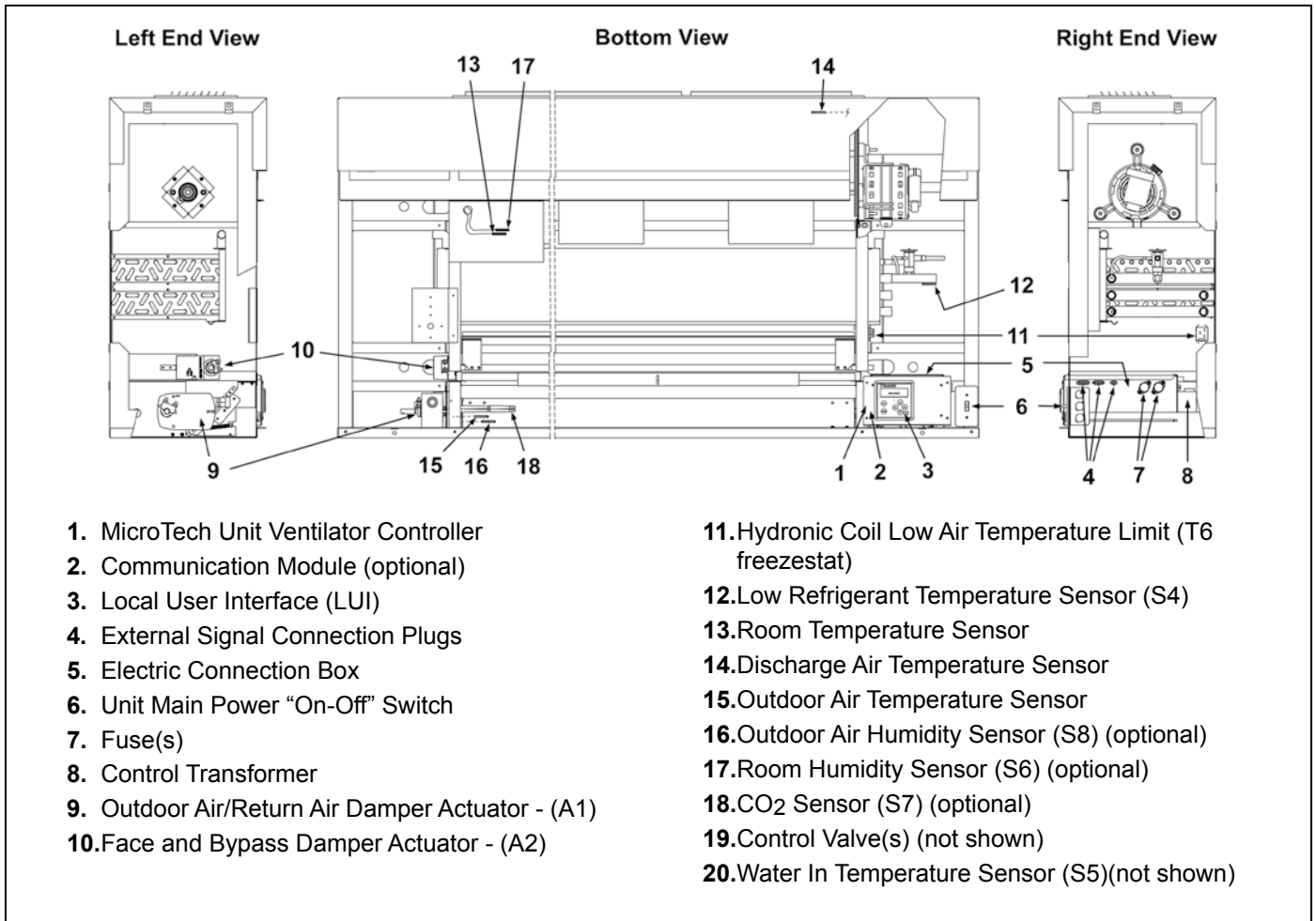

Communication Types

On-board BACnet communication or the optional LONWORKS communication module provide control and monitoring information to your building automation system without the need for costly gateways. Information on BACnet and the optional LONTALK communication module are described below.

MicroTech® Controller with On-Board BACnet MS/TP

The MicroTech controller allows the UVC to inter-operate with systems that use the BACnet (MS/TP) protocol with a conformance level of 3. It meets the requirements of the ANSI/ASHRAE 135-2008 standard for BACnet systems.

LONWORKS SCC Communication Module

This module supports the LONWORKS SCC (Space Comfort Communication) profile number 8500-10. Unit controllers are LONMARK certified with this optional LONWORKS communication module.

Room Temperature Sensors used with MicroTech Unit Controls

Digitally Adjustable Display Sensor – 910247458

The display sensor is used in conjunction with MicroTech equipped units. This digitally adjustable sensor displays room temperature, fan speed (AUTO/HIGH/MEDIUM/LOW), system mode (HEAT/COOL/AUTO/OFF), ALARM, override and occupancy.

Digitally Adjustable Display Sensor – 910247448

The display sensor is used in conjunction with MicroTech equipped units. The sensor has a digital display for temperature, occupancy, alarm, setpoint and status indication. Controls include four buttons for setpoint, occupied/unoccupied request, and override reset.

Basic Room Sensor With Cool to Warm – 910247453

The basic room sensor with adjustment (cool to warm) is used in conjunction with MicroTech equipped units. The sensor has an output for temperature, and LED status indication and includes an override reset button.

Basic Room Sensor – 910247450

The basic room sensor is used in conjunction with MicroTech equipped units. The sensor has an output for temperature, and LED status indication and includes an override reset button.

Table 49: Room Temperature Sensors for BAS Operation

| Room Temperature Sensors used with Unit Ventilator – Building Automated System (BAS) Operation | | Digitally Adjustable Display Sensor | Digitally Adjustable Display Sensor | Basic Room Sensor With Cool to Warm Adjust | Basic Room Sensor |
|--|-----------------------------|---|---|--|--------------------|
| | | Part No. 910247458 | Part No. 910247448 | Part No. 910247453 | Part No. 910247450 |
| Feature | | | | | |
| Setpoint Adjustment | | Digitally Adjustable | Digitally Adjustable | Cool to Warm | None |
| Display | Room Temperature & Setpoint | ● | ● | | |
| Operating Modes | System | Heat-Cool-Auto-Off- | | | |
| | Fan | Auto-High-Medium-Low | | | |
| | Occupancy | LCD Display of Occupied-Unoccupied Icon | LCD Display of Occupied-Unoccupied Icon | | |
| Annunciation | Status LED | LCD Display of Unit Status | LCD Display of Unit Status | ● | ● |
| | LCD Alarm Display | ● | ● | | |
| Reset | Alarm | ● | ● | ● | ● |
| | Setback Override | ● | ● | ● | ● |

CO₂ Sensor for Demand Controlled Ventilation

On units equipped for Demand Controlled Ventilation (DCV) the UVC is configured to use a 0-2000 PPM, 0-10 VDC, single beam absorption infrared gas sensor. CO₂ sensors are available as unit mounted only. An air collection probe (pitot tube and filter) is installed in the return air of the unit (Figure 97).

Figure 97: CO₂ Sensor For Demand Control Ventilation



Actuators

Face & Bypass Damper Actuator

On units equipped with face & bypass damper control, the UVC is configured to operate a proportional, direct-coupled, face & bypass damper actuator. To increase accuracy, the controller has an overdrive feature for the 0% and 100% positions and a periodic (12-hour) auto-zero PI control loop for each modulating actuator.

Figure 98: Face & Bypass Actuator



Outdoor Air/Return Air Damper (OAD) Actuator

The UVC is configured to operate a proportional, direct-coupled actuator for the outdoor air damper. This actuator provides spring-return operation upon loss of power for positive close-off of the outdoor air damper. To increase actuator positioning accuracy, the UVC is provided with an overdrive feature for the 0% and 100% positions and a periodic (12- hour) auto-zero PI control loop for each modulating actuator.

Figure 99: Outdoor Air Damper Actuator



2-Position End-of-Cycle Valve Actuators (Optional)

On units equipped with 2-way or 3-way, end-of-cycle (EOC) valves, the UVC is configured to operate 2-position End-Of-Cycle (EOC) valve actuators (Figure 100). Spring return actuators are used for all End of Cycle (EOC) valves. All wet heat and heat/ cool EOC valves are normally open, and all cooling EOC valves are normally closed.

Figure 100: End of Cycle Valve Actuator



Modulating Valve Actuators (Optional)

On units equipped with modulating valves, the UVC is configured to operate proportional actuators for modulating 2-way and 3-way valves (Figure 101).

Figure 101: Modulating Valve Actuators



2-Way Valve

3-Way Valve

Spring return actuators are used for all modulating valves. All wet heat and heat/ cool valves are normally open, all cooling valves are normally closed.

To determine modulating valve position the UVC uses a separate factory preset, configurable setting for each actuator's stroke time. For accuracy of actuator positioning, the UVC is provided with an overdrive feature for the 0% and 100% positions and a periodic (12-hour) auto-zero PI control loop for each modulating actuator.

A Wide Variety of Input, Output & Alarm Data Points Available

A wide variety of data is available from Daikin Applied unit ventilators when equipped with MicroTech unit controllers in a network situation. They provide a clear picture of just what's happening in each classroom and notify your building automation system of alarm conditions regardless of the protocol you select. Table 50 below shows a list of inputs, outputs and alarm functions available.

Table 50: Network Operation -Typical Data Points¹

| Read/Write Attributes | Read Only Attributes | Read/Write Setpoint Attributes | Typical Alarms |
|---|---|--|--|
| <ul style="list-style-type: none"> Application Mode Compressor Enable Emergency Override Energy Hold Off Heat/Cool Mode Occupancy Override Outdoor Air Humidity Outdoor Air Temperature Reset Alarm Reset Filter Alarm Source (Water In) Temperature Space CO₂ Space Humidity Space Temperature Economizer Enable Heating Setpoint Shift Cooling Setpoint Shift | <ul style="list-style-type: none"> Binary Input Status Binary Output Status UV Software Application Version Compressor Run Time Chiller Water Valve Position Discharge Air Temperature Discharge Air Temperature Setpoint Effective Setpoint Fan Speed F & BP Damper Position Outdoor Air Damper Position Space Fan Runtime Unit Ventilator Controller State Water-Out Temperature WH or CW/HW Valve Position OA Minimum Position | <ul style="list-style-type: none"> Econ. IA/OA Enthalpy Differential Setpoint Econ. IA/OA Temp. Differential. Setpoint Econ. Outdoor Air Enthalpy Setpoint OAD Min. Position Low-Speed Setpoint OAD Min. Position Med.-Speed Setpoint Occupied Cooling Setpoint Occupied Heating Setpoint Space CO₂ Setpoint Space Humidity Setpoint Standby Cooling Setpoint Unoccupied Cooling Setpoint Unoccupied Heating Setpoint | <ul style="list-style-type: none"> Indoor Air Temperature Sensor Failure DX Pressure Fault Indoor Air Coil DX Temperature Sensor Failure Outdoor Air Temperature Sensor Failure Discharge Air Temperature Sensor Failure Outdoor Air Coil DX Temperature Sensor Failure (or) Water Coil DX Temperature Sensor Failure Water-Out Temperature Sensor Failure (or) Water-In Temperature Sensor Failure Space Humidity Sensor Failure Outdoor Humidity Sensor Failure Space CO₂ Sensor Failure Source Temperature (Water-In) Inadequate Indication Change Filter Indication |

¹ Not all data points or alarms listed will be available in all unit ventilator configurations. Humidity and CO₂ points require the use of optional sensors.

ServiceTools™

ServiceTools for MicroTech Unit Ventilators is software for operation on a personal computer. This software provides representation of the sequence of operation and enables the service technician to:

- Monitor equipment operation
- Configure network communications
- Diagnose unit operating problems
- Download application code and configure the unit

This software is a purchased tool for service technicians and will run on PCs with Microsoft Windows, Windows 7 and newer operating systems.

This tool provides more capabilities than the unit's user interface touch pad and is highly recommended for startup and servicing. (It may be required for startup and/or servicing, depending upon unit integration and other requirements.) It does not replace BAS functions, such as system wide scheduling or sequencing, and it cannot serve as a Work Station Monitoring package. ServiceTools interfaces with the MicroTech controller using serial communications through a USB type A connector.

Setpoints and Configuration Parameters

The UVC can save a snapshot of all setpoints and configuration parameters in the controller. Those configurations and setpoints can be saved onto a SD flash memory card, ensuring the controller can be reverted to those settings at a later date. Additionally, the settings saved to a SD can be taken to another UVC and loaded into it. Certain parameters, such as BACnet addressing and location, can be optionally restored to prevent duplication.

Data Trending

Data can be written to an optional SD card inserted into the control unit. The parameters that can be trended through MicroTech can be found in OM 732. Six options for trending frequency are available:

- None
- 10 Minutes
- Occupancy Change
- Hourly
- 1 Minute
- Daily

A separate trend file will be created of each day. If a "Daily" trend is selected, the trend file will contain a header and 1 line of data. If an "Hourly" trend is selected, the trend file will contain a header and 24 lines of data. The last 3 alarms in the Alarm History are always recorded.

Why Classrooms Overheat

Overheated classrooms occur every day in schools in every area of the country. The most serious result is their detrimental effect on students' ability to concentrate and learn. Research has determined that the ability to learn and retain knowledge decreases rapidly as the temperature exceeds recommendations. Overheated rooms also represent wasted fuel, resulting in excessive operating costs.

Correcting an overheating problem in an existing building is very difficult and expensive. It calls for redesign and alteration of the heating and ventilating system, necessitating considerable renovation. This potential problem should be recognized, understood and planned for when heating and ventilating systems are designed for new and existing buildings.

Schools Have Special Needs

Schools have unique heating and ventilating needs, in large part because of their variable occupancy and usage patterns. Fewer cubic feet of space is provided per student in a school building than in any other type of commercial or public building. School classrooms are typically occupied only six hours a day, five days a week, for only three-fourths of the year, with time out for vacations. All in all, this represents approximately 15% of the hours in a year that a classroom is occupied.

To understand the overheating problem in schools, one must first realize that the excess heat comes from what is commonly termed "uncontrolled heat sources." To gain some perspective on how this affects heating and cooling decisions, let's take a look at a typical classroom in the northern section of the midwestern United States.

Suppose we have a classroom that is 24 by 38 feet with 10-foot ceilings and 100 square feet of window area along the outside wall. At an outside temperature of 0°F and a desired room temperature of 72°F, let's assume the normal amount of heat loss from the room to the outside is 55,000 BTUs per hour.

As the outside temperature changes, so does the amount of heat that the room loses. This is represented in Figure 102 by Room Heat Loss Line A, which ranges from 55,000 BTUs per hour at 0°F outside air temperature to zero BTUs at 70°F. Obviously, if the heating system were the only source of heat in the classroom, the solution would be simple: The room thermostat would cause the heating system to supply exactly the amount of heat required to maintain the room at the thermostat temperature setting. In reality, the introduction of excess heat from a variety of uncontrolled sources makes the challenge considerably more complex.

Figure 102: Heat Gain Vs. Heat Loss In Occupied Classrooms

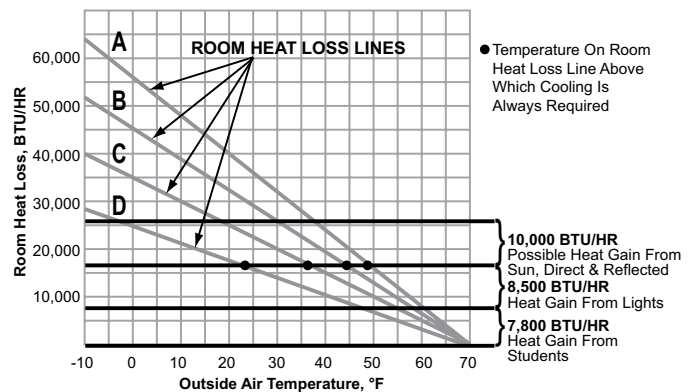

As Figure 102 illustrates, even in very cold weather an occupied classroom is more likely to require cooling than heating.

Heat From Students

Body heat generated by students in a classroom is one of the three primary sources of uncontrolled heat. In a typical classroom of 30 students, the amount of heat given off at all times will vary according to factors such as age, activity, gender, etc. A conservative estimate is 260 BTUs per hour per pupil. Multiply this by 30 and you get a total of 7,800 BTUs per hour added to the room by the students alone. This excess heat is noted in Figure 102 as "Heat Gain from Students."

Heat Gain From Lights

Heat emitted by the lighting system constitutes a second uncontrolled heat source. Artificial lighting is needed in most classrooms even during daylight hours to prevent unbalanced lighting and eye strain. A typical classroom requires approximately 2,500 watts of supplemental lighting to provide properly balanced lighting. Fluorescent lights add heat to the room at the rate of 3.4 BTU per watt per hour, or a total of 8,500 BTU per hour. This extra heat is represented in Figure 102 as "Heat Gain from Lights."

Add the heat gain from lighting to the 7,800 BTUs introduced by student body heat and we now have an extra 16,300 BTU/HR being introduced into the classroom by uncontrolled sources. This heat gain remains constant regardless of the outdoor air temperature.

Solar Heat Gain

The sun is a third uncontrolled source of heat. And, because it is neither positive nor constant, calculating its contribution to the overall heat gain is difficult. Solar heat gain can be the worst offender of the three in classrooms with large windows. Indirect or reflected solar radiation is substantial even on cloudy days, even in rooms with north exposure, as a result of what is termed "skyshine."

To get an idea of the potential effect of the sun, let's assume that the solar heat gain in our hypothetical classroom will peak at 240 BTU/HR per square foot of glass area. If we then assume a glass area of 100 square feet and at least

100 BTU/HR per square foot of glass for solar heat gain, we can calculate a very conservative estimate of 10,000 BTU/HR heat gain through windows. If we add this to the heat from the lights and body heat, total heat gain adds up to 26,300 BTU/HR from sources other than the heating and ventilating system. This is indicated in [Figure 102 on page 78](#) by the top horizontal line, which intersects Room Heat Loss Line A at approximately 37°F. This is a reasonable estimate of the maximum uncontrolled heat gain that can be received in the typical classroom from these common heat sources.

The Analysis

From [Figure 102 on page 78](#) it is evident that, at an outside temperature of 48°F or higher, the heat given off by 30 students and classroom lighting is sufficient to cause overheating. This is true even if the classroom is occupied at night when solar heat gain is not a factor. But, since classrooms are occupied during the day, solar addition provides heat in varying amounts even in classrooms with north exposures. Consequently, the heating and ventilating system in our typical classroom must provide cooling at all times when the outdoor temperature is above 48°F and at any time during colder weather when the solar heat gain exceeds room heat loss.

If we assume an average winter temperature of approximately 33°F in the region where our typical classroom is located, we know that, half of the time, both night and day, the outside temperature will be above 33°F. However, since it is generally warmer during the day, when school is in session, the heating and ventilating system will be required to provide cooling for this classroom during much of the time that the room is occupied.

In this example, we've assumed that our classroom had a room heat loss of 55,000 BTU/HR at a design outdoor air temperature of 0°F (Room Heat Loss Line "A").

Bear in mind, however, that the recent trend in "energy-saving" building design often results in rooms with lower room heat loss, as indicated by Room Heat Loss Lines "B," "C" and "D." At 0°F design outdoor air temperature:

- Room "B" has a room heat loss of 45,000 BTU/HR,
- Room "C" has a room heat loss of 35,000 BTU/HR,
- Room "D" has a room heat loss of 25,000 BTU/HR.

Note the lowering of the temperature above which cooling will always be required as the room heat loss decreases.

We've noted that cooling is always required in Classroom "A" when outdoor air temperatures exceed 48°F. In Classroom "B," "C," and "D" cooling is always

required when outdoor temperatures exceed 44°, 36° and 23°F, respectively ([Figure 102 on page 78](#)).

Now that we understand the reason for classrooms overheating, the solution is simple: The heating and ventilating system must provide cooling to take care of the heat given off in the classroom by uncontrolled heat sources.

Cooling The Classroom

The Daikin Unit Ventilator has become a standard for heating and ventilating systems in schools because it provides the solution for overheating classrooms. The unit ventilator cools as well as heats. During the heating season the outdoor air temperature is nearly always below the desired room temperature. It stands to reason then that the outside air should be used to provide the cooling necessary to keep classrooms down to thermostat temperature.

The classroom unit ventilator does just that. By incorporating an automatically controlled outdoor air damper, a variable quantity of outdoor air is introduced in the classroom, metered exactly to counteract overheating. Since our problem is more one of cooling than of heating, it is evident that more than just the room heat loss must be determined to design a good heating and ventilating system. The cooling requirements should be assessed as well, and the free-cooling capacity of the equipment specified along with the heating capacity required. If this is done, the optimum learning temperature can be maintained in each classroom.

Meeting IAQ Requirements

Good indoor air quality (IAQ), which is important in the home and at work, is no less important to students and faculty in schools. For the past several years, efforts to reduce energy costs in new school buildings have seen the use of tighter construction, sealed windows and heavier insulation. While these construction techniques have helped reduce energy costs, tightly sealed buildings, or envelopes, when combined with increased use of recirculated air, have led to a condition known as sick building syndrome.

In a poorly ventilated school building, fumes and vapors from plastics and other synthetics are often not properly exhausted, while mold, fungus, and bacteria are able to flourish. These conditions can cause various ailments, including nausea, smarting eyes, and coughing, as well as increased student absenteeism and diminished productivity.

For these reasons, the American Society of Heating, Refrigeration and Air Conditioning Engineers (ASHRAE) now has recommendations for minimum ventilations rates for various types of classrooms and no longer endorses the practice of little or no usage of outdoor air.

Daikin Unit Ventilators & VentiMatic Shutters Solve The IAQ Problem

Daikin unit ventilators do a thorough job of maintaining a healthful and productive classroom environment through the introduction of plenty of filtered fresh air directly into the classroom. This feature, which has always been a significant factor in reducing energy costs, is now more important than ever in the promotion of a healthful environment for learning.

It should be kept in mind that a properly designed exhaust system is essential for avoiding indoor air quality problems. Simply put, if room air is not being exhausted in a prescribed fashion, fresh outside air cannot be introduced into the room. Likewise, an excessive amount of outside air will be admitted, wasting energy.

The Daikin VentiMatic shutter, a gravity-actuated room exhaust vent, can solve both these problems. The VentiMatic shutter allows the correct amount of outdoor air to be brought into the room while maintaining a slight positive pressure in the room. This slight positive pressure, maintained during normal operation, can also help prevent the infiltration of undesirable gases into the classroom. See "[VentiMatic™ Shutter – Room Exhaust Ventilation](#)" on page 26

Following ASHRAE Control Cycle II

ASHRAE Cycle II is a very economical sequence of control because only minimum amounts of outdoor air are heated and free outdoor air—natural cooling—is available to offset the large internal heat gain associated with the dense occupancy of classrooms.

Daikin unit ventilators are normally controlled according to ASHRAE Control Cycle II. ASHRAE control cycles apply only to heating, heating-and-ventilating and free-cooling operation. (For more information on the ASHRAE Control Cycle II sequence, see "[ASHRAE Cycle II Operation](#)" on page 90.)

Under ASHRAE Cycle II, the outdoor air damper is closed during warmup of the room. As the room temperature approaches the thermostat setting, the outdoor air damper opens to a predetermined minimum percentage of outside air. The heating coil capacity controller then modulates to maintain the thermostat setting.

If the room temperature rises above the thermostat setting, the heating coil is turned off and the outdoor air damper opens beyond the minimum position to maintain the thermostat setting.

EXAMPLE: For a 60°F entering air mixture temperature and 70°F room temperature, with 30°F outdoor air temperature, 25% outdoor air will produce the 60°F mixture air temperature. When the outdoor air temperature drops to 10°F, 12.5% outdoor air will produce the 60°F mixture air temperature.

Night Setback

Substantial fuel savings can be realized by operating the unit ventilator system at a reduced room setting at night and during other unoccupied periods, such as weekends and holidays. Units with steam or hot-water coils will provide convective heat during the setback period. If the space temperature falls below the setting of the unoccupied thermostat, the unit fans will be brought on to provide additional heat. Units with electric heat coils do not provide convective heat. The electric coil and the unit fans will be brought on to maintain the thermostat setting.

Typical Temperature Control Components

In general, unit ventilators require the following basic DDC electrical components in order to operate on any of the standard unit ventilator ASHRAE cycles of control. The control components listed in this section are for familiarization purposes only and should not be construed as a bill of material.

Outdoor Air Damper Actuator

This is a modulating device under the control of the room and discharge sensors. It positions the outdoor air damper to admit the amount of outdoor air required at any given point in the control cycle. The room air damper is mechanically linked to the outdoor air damper, which permits the use of a single actuator. Electric actuators should be of the spring-return type so that the outdoor air damper closes whenever the electric power supply to the unit is interrupted.

Discharge Airstream Sensor

This device overrides the room sensor and modulates the outdoor air damper toward the closed position when the unit discharge air falls to a potentially uncomfortable temperature.

Temperature Modulation Devices

The temperature of the air entering the room is modulated using one or more of the following devices:

Face and Bypass Damper Control: A modulating damper actuator, under control of the room sensor, positions a face and bypass damper to control the amount of air that passes through or around the unit coil.

Valve Control: A modulating valve, under control of the room sensor, regulates the flow of steam, hot water or chilled water through the unit coil.

Electric Heat Step Control: A modulating step controller, under control of the room sensor, steps individual electric heating elements on and off as required. Staging relays are sometimes used in lieu of a step controller.

Note: *When unit ventilators containing electric heat are ordered without controls (controls by others) the contactors and relays used for staging the electric heat are not provided. This is because the number of stages varies based on the type and manufacturer of the control devices. It is not possible to pre-engineer contactors and relays for all of these variables. The control contractor is responsible for making certain that the controls correctly control the unit's functions.*

Room Sensor

The room sensor is a temperature-sensing device that modulates the intensity of an electric signal to the controlled components within the unit in order to maintain the room sensor's comfort setting. Room sensors can be mounted on the wall or within the unit in a sampling chamber.

Additional Components

Additional components may be required depending on the specific application. They include:

Sampling Chamber: This device is required whenever the room sensor is to be mounted within the unit ventilator rather than on the wall. The sampling chamber is located behind a series of holes in the unit front panel. The sensing element of the room sensor is positioned within the sampling chamber. The unit fans draw a representative sample of room air over the sensing element at a relatively high velocity, which is necessary for rapid control response. Sampling chambers are furnished with MicroTech controls.

Low Temperature Protection: A low temperature limit or freezestat senses the discharge air temperature off the hydronic coil. If the temperature drops below 38°F, the unit ventilator will shut down, closing the outdoor air damper and opening the heating valve.

DX Cooling Control: This sequence switch in the cooling control circuit energizes the condensing unit contactor on a call for mechanical cooling.

DX Cooling Low Ambient Lockout: This lockout must be used on DX split systems to lock out the condensing unit when the outdoor air temperature is below 64°F (17.5°C). This device must be integrated into the control system so that the unit has full ventilation cooling capability during the lockout period.

DX Low Temperature Limit: This limit must be used on DX split system cooling units to de-energize the condensing unit (compressor) when the refrigerant falls below freezing. DX units with MicroTech controls have a factory-installed sensor across the leaving side of the DX coil that provides a representative sample of the coil's temperature.

Meeting AHRI 840 Requirements

The ventilation rate of Daikin Applied unit ventilators is certified and tested per Air Conditioning, Heating and Refrigeration Institute (AHRI) Standard 840. Per this standard, unit ventilators with outside air ventilation and return air dampers must provide ventilation air at a rate of minimum of 80% rated standard air flow. They must also be capable of providing any combination of humidity control, circulation, heating or cooling, and filtering of air.

Face & Bypass Temperature Control

Unit ventilators with face and bypass damper control are available for 2-pipe or 4-pipe applications. Two-pipe chilled/hot water installations require a system changeover from heating to cooling whenever the outdoor air temperature rises to a point that ventilation cooling can no longer offset the heat gains in the space. The reverse happens whenever heating is required. Four-pipe systems have both heating and cooling available whenever needed. With 4-pipe systems, each unit will automatically change over to heating or cooling as the room temperature demands.

Precise Environment Control

Face and bypass damper control units utilize standard unit ventilator cycles of temperature control and bring in up to 100% fresh outdoor air for ventilation (free) cooling of the classroom. The bypass damper allows all air to pass through the heating coil for fast warm-up. A portion passes through the coil and a portion bypasses the coil when less heat is required. All air bypasses the coil when “free” cooling or no heating is required.

The superior ability of the face and bypass damper to control temperature and humidity during cooling operation is well established. Constant chilled water flow maintains the coil surface temperature at or below dew point, providing maximum dehumidification.

Figure 103: Face & Bypass Temperature Control

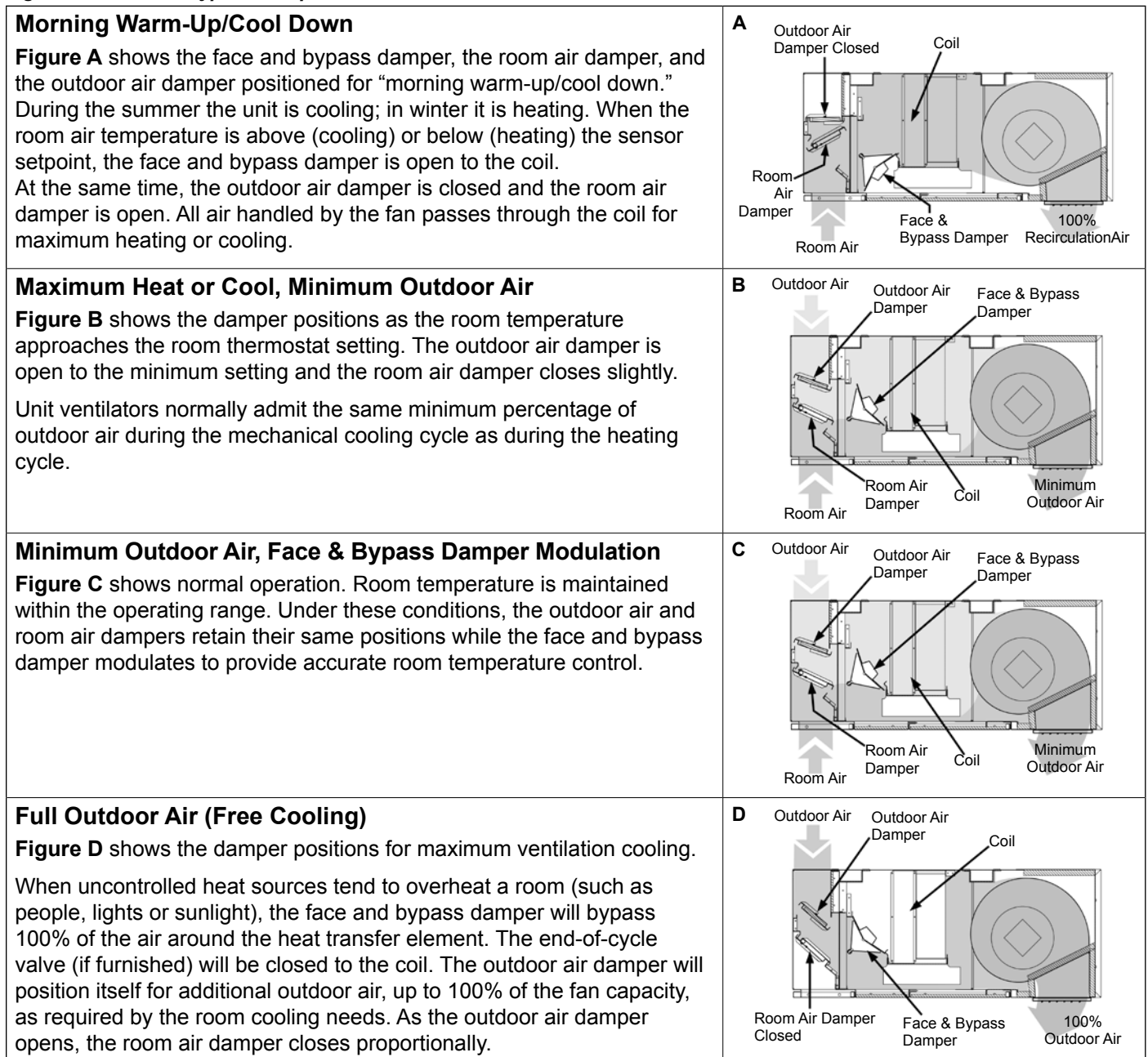

Ease Of System Balancing

With face and bypass damper control, the water in the system is constantly circulating, which maintains a desirable head pressure to the pumps. With fluctuating head pressure eliminated, balancing the system can enable the correct quantity of water in all circuits.

Improved Boiler Economics

In a 2-pipe system, the coil is usually selected for cooling and, during the heating season, extra coil heat transfer is available. Since the water is always being pumped with face and bypass, boiler water temperature can be modulated rather than fixed, reducing the hot water temperature to better match the heating load. This is an opportunity to reduce operating costs. By resetting the boiler hot water to 90°F and modulating upward to 140-160°F for design conditions, boiler economy results in savings. Better room temperature control is available at low heating loads and the system can be quickly and easily changed over from heating to cooling or vice versa.

Since conditions of full heating or full cooling are achieved only 1-2% of the time, savings are available with today's chillers. Load rates at changeover from heating to cooling of 100°F plus are limited and the chiller protected. Daikin chillers have this state-of-the-art system. Considerable savings can be realized when you couple this cooling with today's high-efficiency condensing boilers (which can accept 45°F entering water without damage) and with the elimination of boiler circulating pumps, mixing valves and isolation valves.

Easy Maintenance

A Daikin Applied unit ventilator with face and bypass damper control is easier to maintain. It has fewer moving parts: one pump, one motorized valve, two or three small modular condensing boilers, one or two air-cooled chillers, and, in each classroom, one outdoor air damper actuator, one face and bypass damper, and one fan. The system can deliver the lowest utility cost. And with their long, durable life, replacement/maintenance costs can be deferred. These low costs are desirable to taxpayers and school officials, so limited resources can be used to support teaching.

Reduced Risk Of Coil Freeze

With face and bypass damper control, there is no change in the flow of water through the coil. Coils that have a constant flow of water—especially hot water—cannot freeze. On valve control units, water left in the heating coils after the modulating temperature control valve shuts can freeze and rupture the coil.

Additional freeze protection is afforded by Daikin's double-walled cold weather outdoor damper. It has encapsulated insulation and wool mohair end seals to help prevent unwanted cold air from entering the unit. This construction method further decreases the chance of coil freeze if water flow is inadvertently interrupted.

A low-temperature freezestat, factory installed on all hydronic units, significantly reduces the chance of coil freeze-up. Its wave-like configuration senses multiple locations by blanketing the leaving air side of the coil to react to possible freezing conditions.

Hot Water Reset

Automatic reset should be used to reduce the temperature of the hot water being recirculated as the outdoor air temperature rises. This should be reversed as the outdoor temperature drops. Such adjustments help prevent overheating and reduce fuel costs.

Modulating Valve Temperature Control

Modulating valve-controlled unit ventilators are an alternative to face and bypass control. All air handled by the fans passes through the coil at all times. A valve-controlled unit ventilator is a constant-volume, variable-temperature device that delivers constant air while modulating water flow through a chilled-water coil to maintain the dry bulb (sensible) temperature in the classroom. With water flow through the coil being

modulated, the surface temperature of the coil increases and reduces the coil's ability to remove moisture or dehumidify. The moisture brought from outdoor air, along with the internally generated moisture from students, can result in unacceptable indoor humidity levels. Face and bypass is the preferred method to maintain indoor humidity levels and reduce damaging freezing.

Figure 104: Modulating Valve Temperature Control

| | |
|--|-----------------|
| <p>Morning Warm-Up/Cool Down</p> <p>Figure A shows the modulating valve allowing full flow through the coil and the room air damper and outdoor air damper positioned for morning warm-up/cool-down. In the summer, this is full cooling; in the winter, it is full heating. When the room temperature is above the sensor setpoint (cooling), or below the setpoint (heating), the valve opens for full flow through the coil. All air is directed through the coil(s).</p> | <p>A</p> |
| <p>Minimum Heating</p> <p>Figure B shows the outdoor air damper moved to its minimum position. The modulating valve is still allowing full flow through the coil. Unit ventilators normally admit the same minimum percentage of outdoor air during the heating cycle as during the mechanical cooling cycle. All the air is directed through the coils.</p> | <p>B</p> |
| <p>Minimum Outdoor Air</p> <p>Figure C shows normal operation. Room temperature is maintained by modulating the flow through the coil. The outdoor and room air dampers maintain the same positions and all air is directed through the coils.</p> | <p>C</p> |
| <p>Full Outdoor Air (Free Cooling)</p> <p>Figure D shows the modulating valve closed, allowing no flow through the coil. The outdoor damper is fully open and the room air damper is closed. The sensor setting dictates when the outdoor damper needs to begin closing. When the minimum outdoor damper position is reached, the valve needs to modulate towards the full open position. All the air is directed through the coils. (Care must be taken to ensure coils are not exposed to freezing air conditions when the modulating valve is shut or no water is flowing through coils. See "Increased Coil Freeze Protection" on page 9.)</p> | <p>D</p> |

Modulating Valve Control With Hot Water Or Steam

The description of unit operation given for damper-controlled units is correct for valve-controlled units except that references to face and bypass dampers and end-of-cycle valves should be disregarded. The capacity of the heating coil will be regulated by a modulating control valve and all air handled by the unit will pass through the heating coil at all times.

Hot Water Reset

Hot water system controls should include a provision for resetting the temperature of the supply hot water in relation to the temperature of the outdoor air. A hot water temperature of 100°-110°F, is suggested when the outdoor air temperature is 60°F. The upper limit of the hot water temperature will be dictated by the winter design conditions.

The need for hot water reset controls is not limited to applications involving unit ventilators with face and bypass control. Valve control performance will be improved as well. When the supply water temperature is far in excess of that required to offset the heat loss of the space, the smooth modulating effect of the control valve is lost. The control valve will cycle between slightly open and fully closed. The effect of heat conduction through a closed valve will also be reduced when hot water reset is used.

Freeze Protection

System freeze protection is an important consideration on units utilizing hydronic coils. On valve-controlled units, water left in the heating or cooling coils and exposed to freezing outdoor air after the modulating valve shuts can freeze and rupture the coil. Flowing water will not freeze. In addition, it is very important to correctly size the modulating control valve and control the supply water temperature to provide constant water flow. If this situation cannot be guaranteed, an antifreeze solution must be employed to reduce the possibility of coil freeze.

Coil Selection

An extensive choice of coil offerings means that, with Daikin unit ventilators, room conditions can be met using almost any cooling or heating source. All coils are located safely beneath the fans and are designed for draw-thru air flow. All coils have their own un-shared fin surfaces (some manufacturers use a continuous fin surface, sacrificing proper heat transfer). The result is maximum efficiency of heat transfer, which promotes comfort and reduces operating costs.

An air break between coils in all Daikin units is used to enhance de-coupling of heat transfer surfaces—providing full capacity output, comfort and reduced operating costs.

All water, steam and direct expansion (DX) coils are constructed of aluminum fins with a formed, integral spacing collar. The fins are mechanically bonded to the seamless copper tubes by expansion of the tubes after assembly. Fins are rippled or embossed for strength and increased heat transfer surface. Coils and units are AHRI capacity rated.

High-Quality Water Coils

Daikin Applied water coils rely on advanced heat transfer to provide extra cooling capacity for today’s increased ventilation requirements. Tuned internal water flow and a balanced header design, together with additional surface area in the air stream, increase heat transfer to satisfy the increased need for dehumidification.

A manual air vent is located on the top of the coil header of all floor hydronic coils. (Figure 105). This allows air to be purged from the coil during field start-up or for maintenance.

A manual drain plug (Figure 105) is provided at the bottom of the coil header for coil drainage. Some competitors may not provide for drainage of coils.

Figure 105: Manual Air Vent & Drain Plug

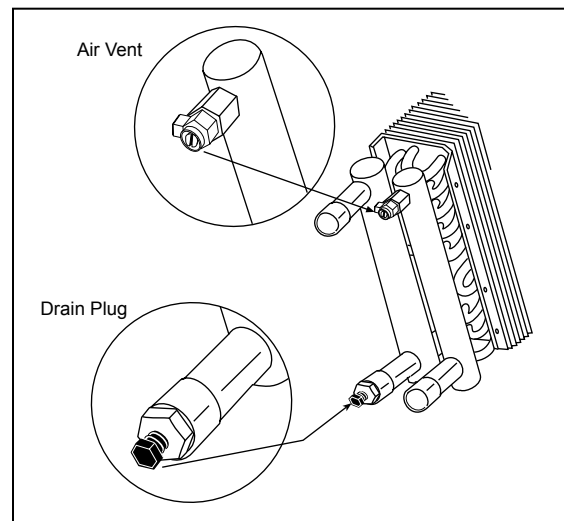

Long Lasting Electric Heating Coils

With our draw-thru design, electric coils are directly exposed to the air stream. They come with a built-in switch to de-energize the coil when the center front panel is removed. A unit-mounted disconnect switch is included. A continuous electric sensory element for high temperature is not required because the air is drawn smoothly and evenly across the coils, prolonging life. (Blow-thru designs use cal rods inserted into the tube of a fin tube coil that results in reduced heat transfer. The constant movement of the electric heating cal rod within the tube shortens life.)

Even Distribution Steam Coils With Vacuum Breakers

Steam distribution coils provide even distribution of steam and even discharge air temperatures. A vacuum breaker relieves the vacuum in the steam coil to allow drainage of condensate. This eliminates water hammer and greatly reduces the possibility of coil freeze-up.

DX Split Systems

Daikin unit ventilators are available with direct expansion (DX) cooling coils that are equipped with thermal expansion valves. Unit ventilators with DX coils operate as a system with most properly sized R-410A condensing units. In most classroom applications, if the unit ventilator and the condensing unit are sized properly, the application should fulfill its design expectations.

The proper selection of a DX split system unit ventilator for a classroom requires special considerations. This is due to the high amount of outdoor air ventilation required and to the occupied and unoccupied cooling requirements. Because of the high number of occupants in classrooms, cooling is required even when the outside air temperature is very mild. With mild ambient conditions, down to 55°F, the system can create colder discharge air temperatures than desired and can even trip the DX low temperature limit on the unit.

DX for Heat Pump Operation

The DX coil will have a TXV bypass installed to allow for split-system pairing with a heat pump condensing unit, to allow for field-supplied refrigerant heating. This option is only selectable on units with Digital Ready or Control by Others.

Condensing Unit Selection

Proper sizing of the field-supplied condensing units is important for trouble-free operation. An oversized condensing unit can reduce performance and cause operational problems, such as:

- Rapid temperature pull down, causing short cycling and potential compressor damage.

- Poor temperature and humidity control.
- Low saturated evaporator coil conditions.
- Low discharge air temperatures.

If the DX system is oversized for the room loads the compressor will have short run times. When rooms are occupied, unit ventilators provide outdoor air to the space continuously. In humid areas, the outdoor air is laden with moisture. The room thermostat responds to the room sensible temperature. With short compressor run times (oversized condition) the system is unable to extract the moisture and the humidity level builds, sometimes exceeding 60 percent.

To properly size the unit ventilator, determine the cooling load based on May and September conditions at 1 pm when the classroom is occupied. Do not select units for July or August, after 3 pm, or when the classroom is unoccupied. Select a properly sized unit based on the calculated cooling load, ambient air temperature and enter air temperature to the coil. If the calculated cooling load falls between two unit sizes, select the smaller of the two units to minimize the potential problems seen with oversized units.

A general rule for DX unit sizing is 400 cfm per ton of cooling capacity. If the 400 cfm per ton criteria is followed, most problems can be avoided. Review the design selection for the system and a typical low ambient condition to determine if the suction temperatures are below an acceptable level.

Table 51 shows the recommended condensing unit size, based on nominal tons, for each size unit ventilator. The Table is based on 400 plus cfm per ton for high-speed operation, at design conditions. If you anticipate a lower-speed DX cooling operation, additional static pressure, or lower outdoor ambient temperature operation, a smaller condensing unit should be considered.

Table 51: Condensing Unit Size Selection

| Unit Vent Model | Unit Vent CFM Nominal | Condensing Unit Size Tons Nominal |
|-----------------|-----------------------|-----------------------------------|
| H07, V07 | 750 | 1-1/2 |
| H10, V10 | 1000 | 2-1/2 |
| H13, V13 | 1250 | 3 |
| H15, V15 | 1500 | 3-1/2 |
| H20, V20 | 2000 | 4 |

Control Considerations

Most unit ventilators for classroom applications require compressorized cooling below 75-80°F outdoor ambient due to internal student, equipment and solar loads. For effective system operation and correct thermal expansion valve operation at these conditions, condensing unit head pressure control is required. A hot gas bypass system or an evaporator minimum pressure regulator may also be required to maintain suction pressure.

The unit ventilator incorporates provisions for wiring to the contactor in the condensing unit. A 5-minute delay relay is included to reduce compressor cycling. On Digital Ready and Controls By Others units, a DX low limit is included to help protect against abnormally low evaporator coil temperatures caused by unit ventilator motor failure, blocked air filters, or other restrictions to airflow.

When MicroTech unit ventilator controls are provided, the controller operates the condensing unit contactor, as needed, to provide cooling when required.

When controls are not provided by Daikin, the normally closed contacts of the DX low limit should be electrically connected (following all appropriate codes) to disable the compressor when contacts open. Controls must be designed to keep the unit ventilator fan running when the compressor is on, so that the face and bypass damper is full face for compressorized cooling operation and other system safeties are provided and integrated into the system controls correctly.

When a DX coil is used for the main source of cooling, the outdoor condensing unit will be cycled on and off as required to maintain the room temperature.

A low temperature thermostat control is inserted into the DX coil to prevent frosting. When tripped, the outdoor condensing unit is locked out and the indoor unit ventilator fan continues to run. When the DX coil temperature rises above the trip set point, the outdoor condensing unit will be allowed to operate.

The outdoor condensing unit is also locked out based on outside air temperature. If the outside air is below the DX outside air low limit the outdoor condensing unit is locked out and cooling is provided by the economizer of the unit ventilator.

Condensing Unit Installation

The condensing unit must not be located more than 30 feet above the unit ventilator and should be located at least 24 inches from a wall or other obstruction to provide unrestricted airflow and to allow for service access. Since condenser discharge air is vertically directed, do not allow any obstruction within 6 feet (measured vertically) from the top of the condensing unit.

Control circuit power, located in the unit ventilator right end compartment, is obtained from a 24-volt transformer furnished by Daikin. The transformer is wired to the fan control switch to de-energize the 24-volt circuit when the switch is in the off position. The condensing unit must be controlled by the same room sensor that controls the unit ventilator.

The temperature control contractor must field supply a low-ambient thermostat in the 24-volt circuit to prevent operation of the condensing unit when the outdoor air temperature is below 60°F. Wire this device into the

temperature controls in such a manner that, when the low ambient thermostat opens at 60°F, the unit ventilator is returned to the heating-only mode with full ventilation cooling capabilities.

Typical System Wiring And Piping

General system wiring and piping for a DX system are shown in Figure 106 and Figure 107. For additional information, see Daikin Unit Ventilator Installation Manual IM 830.

Figure 106: Typical DX System Wiring

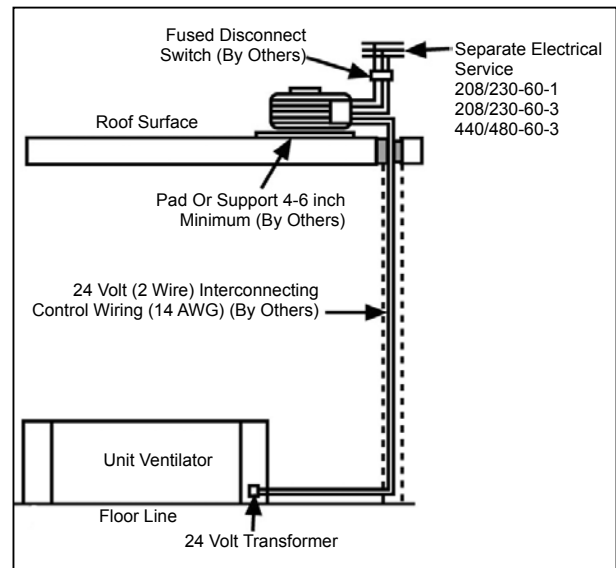
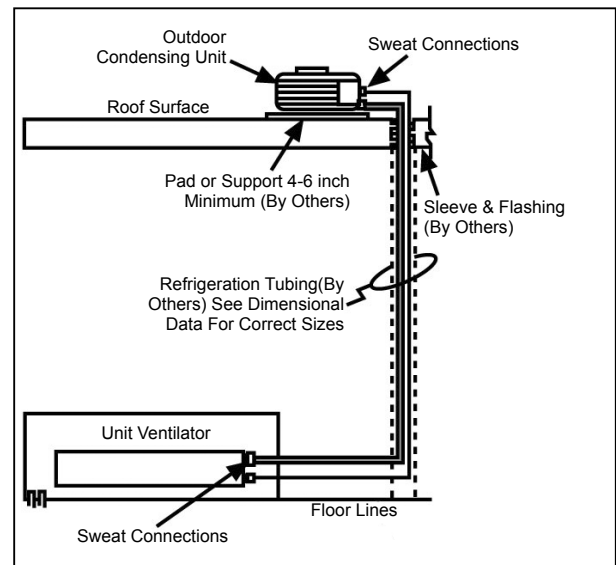

Figure 107: Typical DX System Piping



Nominal cooling capacities are based on 20 feet (one way) of refrigerant tubing between the unit ventilator and the condensing unit. Cooling capacities will be reduced by 20 BTU for each foot in excess of 20 feet. Refrigerant tubing must not exceed 90 feet.

Systems using refrigerant lines longer than 20 feet between the unit ventilator and condensing unit may experience a slight capacity reduction and require crankcase heaters, additional refrigerant oil and refrigerant, and special piping considerations. Clean, refrigerant grade tubing must be used and precautions taken to prevent oxidation and scale formation inside the tubing during brazing. Adequate system isolation valves are required. A filter drier and sight glass are recommended. For specific recommendations on suction and liquid line sizes, routing and length limits, follow the condensing unit manufacturer's recommendations and the ASHRAE Guide.

Most condensing units are pre-charged with refrigerant (R-410A) for a nominal length of tubing. It may be necessary to add additional charge. The system, including the unit ventilator coil, must be leak tested and evacuated before charging.

Proper refrigerant charge is critical for optimum system operation. Refer to the condensing unit manufacturer's start-up documents to determine the proper system charge.

Digital Ready Systems

For unit ventilator applications where controls are to be supplied by others, specifying a Digital Ready system can greatly simplify control installation.

Digital Ready systems come with a factory-installed, pre-wired package of selected Direct Digital Control (DDC) components. This greatly facilitates the field hook up of a DDC unit ventilator controller that is compatible with these components and that is capable of providing the standard ASHRAE II cycle (see "[ASHRAE Cycle II Operation](#)" on page 90).

Note: *It is the responsibility of the control supplier to ensure the controls operate correctly and protect the unit.*

Digital Ready systems include the following components, which are factory wired and powered:

1. A non-fused power interrupt switch.
2. Hot line(s) for the fan motor and controls protected by factor- installed cartridge type fuse(s).
3. A three-speed HIGH-MEDIUM-LOW-OFF motor fan speed switch.
4. A 75 VA, 24-volt NEC Class 2 transformer for the 24-volt power supply.
5. Three 10-pole, Europa-type, 16 awg terminal strips rated for 10 amps at 300 volts with nickel-plated connectors and zinc-plated clamping screws.
6. Approximately 8" x 21" (203mm x 533mm) of space provided in the unit ventilator's left end compartment for unit ventilator controller mounting (by others).
7. Interface to the fan motor start/stop relay (R4).

8. Interface to a factory-installed low-air-temperature-limit freeze-stat (T6). The freeze-stat cuts out below 38±2°F and automatically resets above 45±2 °F. It responds when any 15% of the capillary length senses these temperatures. And, it is wired so that upon T6 cut out, the outside air damper closes, the hot water valve opens and the 24 volt power supply to the terminal strip (T6 Sig) is interrupted.
9. Discharge air temperature sensors: 10 K ohm NTC (Negative Temperature Coefficient) and 1 K ohm PTC (Positive Temperature Coefficient) located on the second fan housing from the right side of the unit.
10. Room temperature sensors: 10K ohm (NTC) and 1Kohm (PTC).
11. Outdoor air temperature sensors: 10K ohm (NTC) and 1Kohm (PTC).
12. A direct-coupled, proportional-control (2 to 10 VDC or 4 to 20 mA) outdoor air/return air damper actuator with spring return.
13. A direct-coupled, proportional-control (2 to 10 VDC or 4 to 20 mA) face and bypass damper actuator without spring return.
14. Interface from the terminal board with one or two end-of-cycle DDC valves with spring return actuators (by others) providing 24-volt power. Open/shut signal from unit ventilator controller (by others).
15. A 24-volt power wiring harness from the right to left-hand end compartment of the unit, through the built-in metal wire raceway, and terminating at three terminal blocks.
16. DX low-limit designed to protect against abnormally low evaporator coil temperatures (DX units only).

Note: *See "[Required Control Sequences](#)" on page 90 for control sequences that should be incorporated for equipment protection and occupant comfort.*

Field-Installed Controls By Others & Digital Ready Controls

There are many advantages to having the basic temperature controls in Daikin units be MicroTech and factory-installed in the unit ventilator prior to shipment (see "[MicroTech® Controls \(Optional\)](#)" on page 23). However, factory installation of controls cannot always be achieved. For example, sometimes the specified controls are nonstandard and as such deviate from the pre-engineered DDC control packages available.

A particular school system may have a preferred temperature control supplier that is unable to interface with standard unit ventilator controls or may decide to field-install them. In such cases, we will ship the unit without any temperature controls. It is the responsibility of the automatic temperature control supplier to provide a control package specifically for installation in the Daikin unit ventilator.

The responsibility for proper control operation and application always rests with the Automatic Temperature Control (ATC) contractor regardless of whether the controls are factory installed or field installed.

The effect of misapplied or improperly installed controls can go beyond unacceptable or poor temperature control: unit ventilator components may be damaged by control misapplication. Brief examples of this include:

- Frozen hydronic coils due to improper or lack of freeze protection and/or incorrect control cycle (failure to close outdoor air damper and open the hot water temperature control valve during night cycle, full shutoff of water through a coil exposed to freezing air, etc.)
- Compressor failures where condensing units are permitted to operate at low ambient conditions or without room air fan operation for prolonged periods.
- Failure of Daikin Applied furnished protective devices due to excessive recycling caused by improper control cycle.

Daikin Applied disclaims all responsibility for any unit component failure that may occur due to improper temperature control application or installation.

The following presents information on specific factory-provided equipment protective devices and their suggested use by others in non-MicroTech control sequences. The Automatic Temperature Control supplier is responsible for correct operation and unit protection.

ASHRAE Cycle II

We strongly recommend that ASHRAE Cycle II be implemented with all unit ventilators using controls by others. ASHRAE Cycle II is a very economical sequence since only the minimum amount of outside air is conditioned and free natural cooling is available. See "ASHRAE Cycle II Operation" on page 90.

During warm-up (any classroom temperature 3°F or more below heating setpoint), the outdoor air damper is closed and the unit conditions only room air. As room temperature approaches the heating setpoint the outdoor air damper opens to a position that permits a predetermined minimum amount of outside air to be drawn in. Unit capacity is then controlled as needed to maintain room setpoints. If room temperature rises above room cooling setpoint, and the outside air is adequate for economizer cooling, then the outdoor air damper may open above the minimum position to provide economizer cooling.

ASHRAE Cycle II requires that a minimum of three temperature measurements be made:

1. Classroom temperature.
2. Unit discharge air temperature.
3. Outdoor air temperature.

Additionally, the control sequence should incorporate a Discharge Air Low Limit function which requires a discharge air temperature sensor and can override classroom temperature control in order to maintain a discharge air temperature setpoint of 55°F.

When the discharge air temperature drops below 55°F, the discharge-air low-limit function will disable cooling (if enabled) and modulate the unit's heating capability as needed to maintain the 55°F discharge-air setpoint regardless of room temperature.

If the unit's heating capability reaches 100%, then the discharge air low-limit function will modulate the outdoor air damper toward closed to maintain the 55°F discharge air setpoint. Outdoor air temperature is used to determine when to use economizer as a first stage of cooling, and when to use mechanical or hydronic cooling as the first stage of cooling.

Variable Airflow

An EC motor with optional "variable fan speed control" allows for MicroTech controls or a field-provided DDC controller to modulate the unit airflow between 50% and 100% of nominal unit airflow in a single zone variable air volume sequence. In continuous fan mode the benefits of Single Zone VAV include sound reduction, energy savings, and consistent and precise temperature control for improved comfort with better air mixing and less stratification. In humid climates, the ability to deliver a wide range of fan speeds is particularly effective for de-humidification.

Figure 108: 0-10VDC Motor Operation

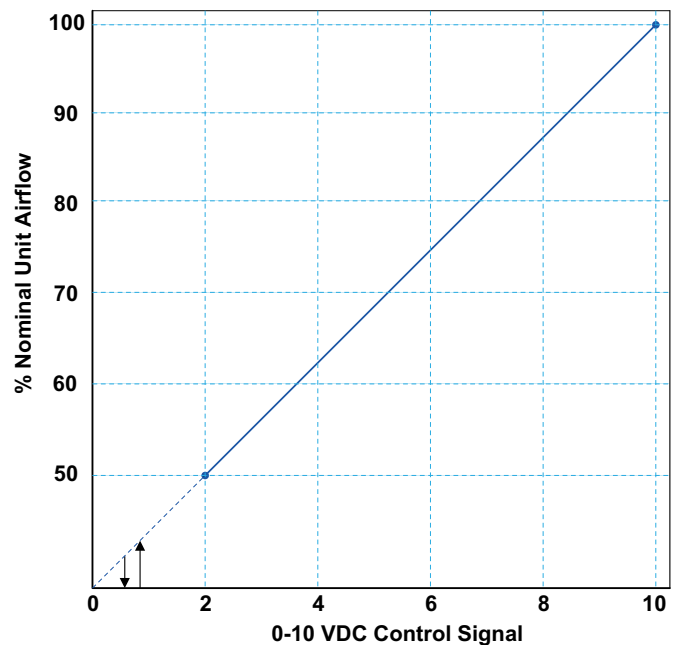

Required Control Sequences

When using controls by others or digital-ready units, the following control sequences should be incorporated for equipment protection, and occupant comfort. Not including them may void the unit warranty. It is the responsibility of the Automatic Temperature Control supplier to ensure the controls operate correctly and protect the unit.

DX Low Temperature Limit Sequence

Each of the following units comes with a factory-installed DX Low Temperature Limit switch:

- DX Cooling With Electric Heat
- DX Cooling Only
- DX Cooling With Steam Or Hot Water Heat Using Valve Control
- DX Cooling With Steam Or Hot Water Heat Using Face And Bypass Damper Control

Its function is to temporarily de-energize the DX system when the DX coil becomes too cold. This switch has a cut-out setting of no less than 28±3°F and a cut-in temperature setting of approximately 48±3°F. When the switch cuts out due to low temperatures the compressor (condensing unit) must be de-energized until the switch cuts in (coil has warmed up).

The condensing unit should have its own high-pressure safety sequence or head pressure control and a Low Ambient Temperature Lockout feature which prevents DX cooling operation when the outside air temperature drops below 60°F. Cooling should be provided via an outdoor air damper economizer function when the outside air temperature drops below 60°F.

DX Cooling Sequence with Steam or Hot Water Heat and face and bypass Damper Control

For this configuration, a heating End-Of-Cycle valve must be used so that hydronic heat can be switched off when DX cooling is required. Improper system operation will result if this valve is not provided. When cooling is required, the controls must force the face and bypass damper to a full-face position prior to starting DX cooling. See "DX Split Systems" on page 86 for additional controls required for DX operation.

Chilled-Water Cooling Sequence with face and bypass Damper Control and Electric Heat

When heating is required, the controls must force the face and bypass damper to a full-face position prior to energizing the electric heaters.

Figure 109: ASHRAE Cycle II Operation

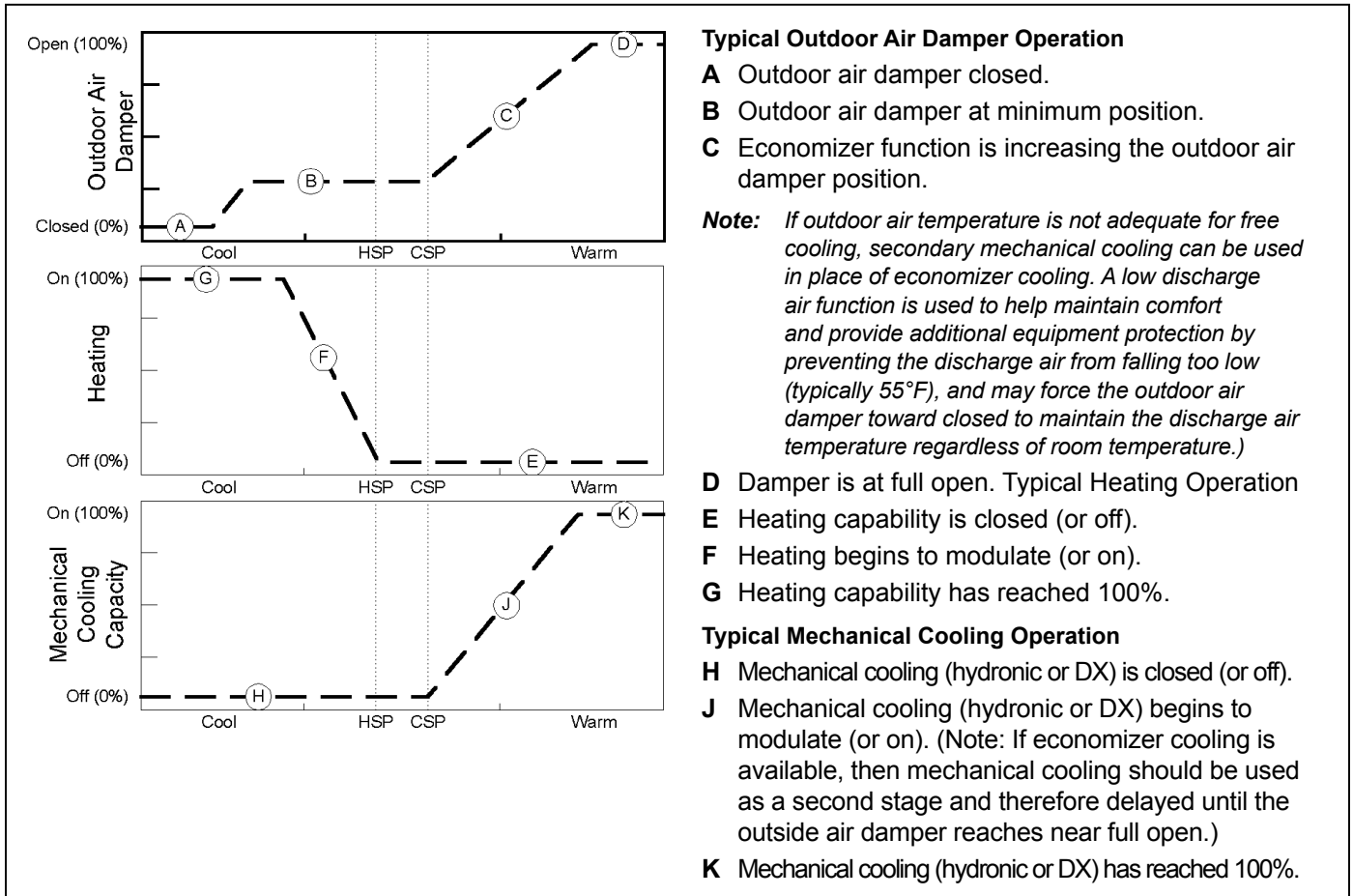

End-Of-Cycle (EOC) Valve Operation

The intended purpose of an EOC valve is to reduce the chances of conductive radiant overheating or over-cooling which can occur when the face and bypass damper is in the full bypass position (i.e., no heating or cooling required).

A heating EOC valve must be used on units with DX cooling coupled with steam or hot water heat and face and bypass damper temperature control. It is optional for the remaining models. However, it is strongly recommended that heating or heat/cool EOC valves be used on all face and bypass units with heating capability to prevent overheating.

Heat/Cool EOC Valve (2-pipe)

For units with chilled-water cooling and hot-water heating (2 pipe) and face and bypass damper control:

- The heat/cool EOC valve should be a normally open, spring return (open), two position valve.
- A water-in temperature sensor should be used to determine whether the supply water temperature is appropriate for heating or cooling. The sensor should be located on the water supply in an area where there is continuous water flow. A 3-way EOC valve is recommended.

In addition:

1. **Heating Operation:** When the room temperature is 2°F or more below the heating setpoint and hot water is available, the EOC valve should open and remain open until the room temperature becomes equal to the heating setpoint or higher.
2. **Cooling Operation:** When room temperature is 2°F or more above the cooling setpoint and cold water is available, the EOC valve should open and remain open until the room temperature becomes equal to the cooling setpoint or less.
3. **Operation Due to Outside Air Temperature:** If the outside air temperature is equal to or less than 35°F, then the EOC valve should open and remain open until the outdoor air temperature reaches 37°F. or higher.

Heating EOC Valve

For steam or hot water heat only with face and bypass damper control; chilled water cooling with steam or hot water heating (4 pipe) with face and bypass damper control; steam or hot water heat with face and bypass damper control coupled DX cooling:

The heating EOC valve should be a normally open, spring return (open), two position valve.

In addition:

1. **Heating Operation:** When the room temperature is 2°F or more below the heating setpoint, the EOC valve should open and remain open until the room temperature becomes equal to the heating setpoint or higher.

2. **Operation Due To Outside Air Temperature:** If the outside air temperature is equal to or less than 35°F, the EOC valve should open, the EOC should then remain open until the outdoor air temperature reaches 37°F. or higher.

Cooling EOC Valve

For chilled water cooling with steam or hot water heating (4 pipe) with face and bypass damper control; chilled water cooling only with face and bypass damper control; chilled water cooling with face and bypass damper control coupled electric heat:

The cooling EOC valve should be a normally closed, spring return (closed), two position valve.

1. **Cooling Operation:** When room temperature is 2°F or more above the cooling setpoint, the EOC valve should open and remain open until the room temperature becomes equal to the cooling setpoint or less.
2. **Operation Due To Outside Air Temperature:** If the outside air temperature is equal to or less than 35°F, and the face and bypass damper is in the full bypass position, the EOC valve should open. The valve should remain open until the outdoor air temperature reaches 37°F or higher or if the face and bypass damper is not in the full bypass position.

Water Coil Low Air Temperature Limit (Freezestat) Operation

The Water Coil Low Air Temperature Limit, or freezestat, function is intended to help protect the water coil from extremely low air conditions. All units with hydronic coils ship with a freezestat. The freezestat has a cut-out temperature setting of no less than 38±2°F and a cut-in temperature setting of approximately 45±2°F. The freezestat is intended as a backup in case the normal operating controls fail to protect the equipment. It is used in the following manner:

Face And Bypass Damper Control Applications

Hot Water Heat Only or Chilled Water Cooling And Hot Water Heating (2 Pipe): The length of the freezestat is secured to the leaving air face of the heating coil. When the freezestat cuts out due to low temperatures the following should occur:

- The outdoor air damper is closed.
- The heating EOC valve is forced to full open.
- The face and bypass damper modulates as needed to maintain space temperature.

When the freezestat cuts in after cut-out, normal operation may return.

Chilled Water Cooling With Hot Water Heating (4 Pipe):

If the cooling coil is in the first position and the heating coil in the second position, the freeze-stat is secured to the leaving air face of the first position coil (cooling coil).

Note: *The freeze-stat is placed between the first and second coils. If you use glycol in the first coil, then you may move the freeze-stat to the leaving air side of the second coil. If you do not use glycol in the first coil, leave the freeze-stat where it is.*

If the cooling coil is in the second position, the heating coil is in the first position and the heating coil is hot water, the freeze-stat is secured to the leaving air face of the first position coil (heating coil).

When the freeze-stat cuts out due to low temperatures, the following should occur:

- The outdoor air damper is closed.
- The cooling and heating EOC valves are forced to full open.
- If heating is required, the face and bypass damper modulates normally to maintain room temperature.

When the freeze-stat cuts in after cut-out, normal operation may return.

Chilled Water Cooling Only: The freeze-stat is secured to the leaving air face of the cooling coil. When the freeze-stat cuts out due to low temperatures, the following should occur:

- The outdoor air damper is closed.
- The cooling EOC valve is forced to full open.
- If cooling is required, the face and bypass damper modulates as needed to maintain space temperature.

When the freeze-stat cuts in after cut-out, normal operation may return.

Chilled Water Cooling With Electric Heat: The freeze-stat is secured to the leaving air face of the cooling coil. When the freeze-stat cuts out due to low temperatures the following should occur:

- The outdoor air damper is closed.
- The cooling EOC valve is forced to full open.
- If cooling is required, the face and bypass damper modulates as needed to maintain room temperature.
- If heating is required, the face and bypass damper goes to full face and electric heat is used as needed to maintain space temperature.

When the freeze-stat cuts in after cut-out, normal operation may return.

DX Cooling With Hot Water Heat & face and bypass Control: The freeze-stat is secured to the leaving air face of the hot water heating coil. When the freeze-stat cuts out due to low temperatures, the following should occur:

- The compressor (condensing unit) is de-energized.

- The outdoor air damper is closed.
- The heating EOC valve is forced to full open.
- The face and bypass damper modulates as needed to maintain space temperature.

When the freeze-stat cuts in after cut-out, normal operation may return.

Valve Control Applications

System freeze protection must be considered on valve controlled units utilizing hydronic coils. Non-flowing water in heating or cooling coils that are exposed to freezing outdoor air can freeze and rupture the coil (after the modulating valve shuts). The modulating control valve must be correctly sized and the supply water temperature controlled to ensure constant water flow. If this cannot be guaranteed, use an antifreeze solution to eliminate the possibility of coil freeze.

Hot Water Heat Only or Chilled Water Cooling And Hot Water Heating (2 Pipe): The freeze-stat is secured to the leaving air face of the hot water heating coil. When the freeze-stat cuts out due to low temperatures, the following should occur:

- The outside air damper is closed.
- The unit fan is de-energized.
- The heating valve is forced to full open.

When the freeze-stat cuts in after cut-out, normal operation may return.

Chilled Water Cooling With Hot Water Heating

(4 Pipe): If the cooling coil is in first position and the heating coil is in second position, the freeze-stat is secured to the leaving air face of the first position coil (cooling coil).

Note: *The freeze-stat is placed between the first and second coils. If you use glycol in the first coil, then you may move the freeze stat to the leaving air side of the second coil. If you do not use glycol in the first coil, leave the freeze-stat where it is.*

If the cooling coil is in the second position, the heating coil is in the first position, and the heating coil is hot water, the freeze-stat is secured to the leaving air face of the first position coil (heating coil).

When the freeze-stat cuts out due to low temperatures, the following should occur:

- The outdoor air damper is closed.
- The unit fan is de-energized.
- The heating valve is forced to full open.

When the freeze-stat cuts in after cut-out, normal operation may return.

Chilled Water Cooling Only: The freeze-stat is secured to the leaving air face of the cooling coil. When the freeze-stat cuts out due to low temperatures, the following should occur:

- The outdoor air damper is closed.
- The cooling valve is forced to full open.

When the freeze-stat cuts in after cut-out, normal operation may return.

Chilled Water Cooling Coupled With Electric Heat:

The freeze-stat is secured to the leaving air face of the cooling coil. When the freeze-stat cuts out due to low temperatures, the following should occur:

- The outdoor air damper is closed.
- The cooling valve is forced to full open.
- Electric heat is used as needed to maintain space temperature.

When the freeze-stat cuts in after cut-out, normal operation may return.

DX Cooling With Hot Water Heat & Valve Control:

The freeze-stat is secured to the leaving air face of the hot water heating coil. When the freeze-stat cuts out due to low temperatures, the following should occur:

- The compressor (condensing unit) is de-energized.
- The outdoor air damper is closed.
- The unit fan is de-energized.
- The heating valve is forced to full open.

When the freeze-stat cuts in after cut-out, normal operation may return.

Unit Installation

Ceiling unit ventilators are typically applied to bring outdoor air directly to classrooms, interior rooms or spaces of a school such as a computer teaching room, auditorium, gymnasium or library. Units, when correctly applied, are capable of operating in a free blow application or against external statics of up to 0.45 inches w.g. See "Unit Arrangements" beginning on [page 95](#).

The unit can be mounted in an exposed position, in a soffit, partially recessed, fully recessed or concealed. See [Figure 12 on page 10](#). Wall guard flanges are a standard accessory for partially and fully recessed units, to provide a finished appearance at the ceiling.

Accessibility to fully recessed units should be considered. See [Figure 110](#). When hanging, the unit should be level both front to back and side to side. This aids in condensate removal from the drain pan.

The unit is equipped with several inlet and discharge arrangements to satisfy numerous application needs. One-inch, field-installed duct collars are provided for field attachment to the supply-air outlet. Locate the unit ventilator as close as practical to the outdoor air intake opening. Insulate the outdoor air duct to reduce sweating and temperature rise.

Figure 110: Accessibility to fully recessed units

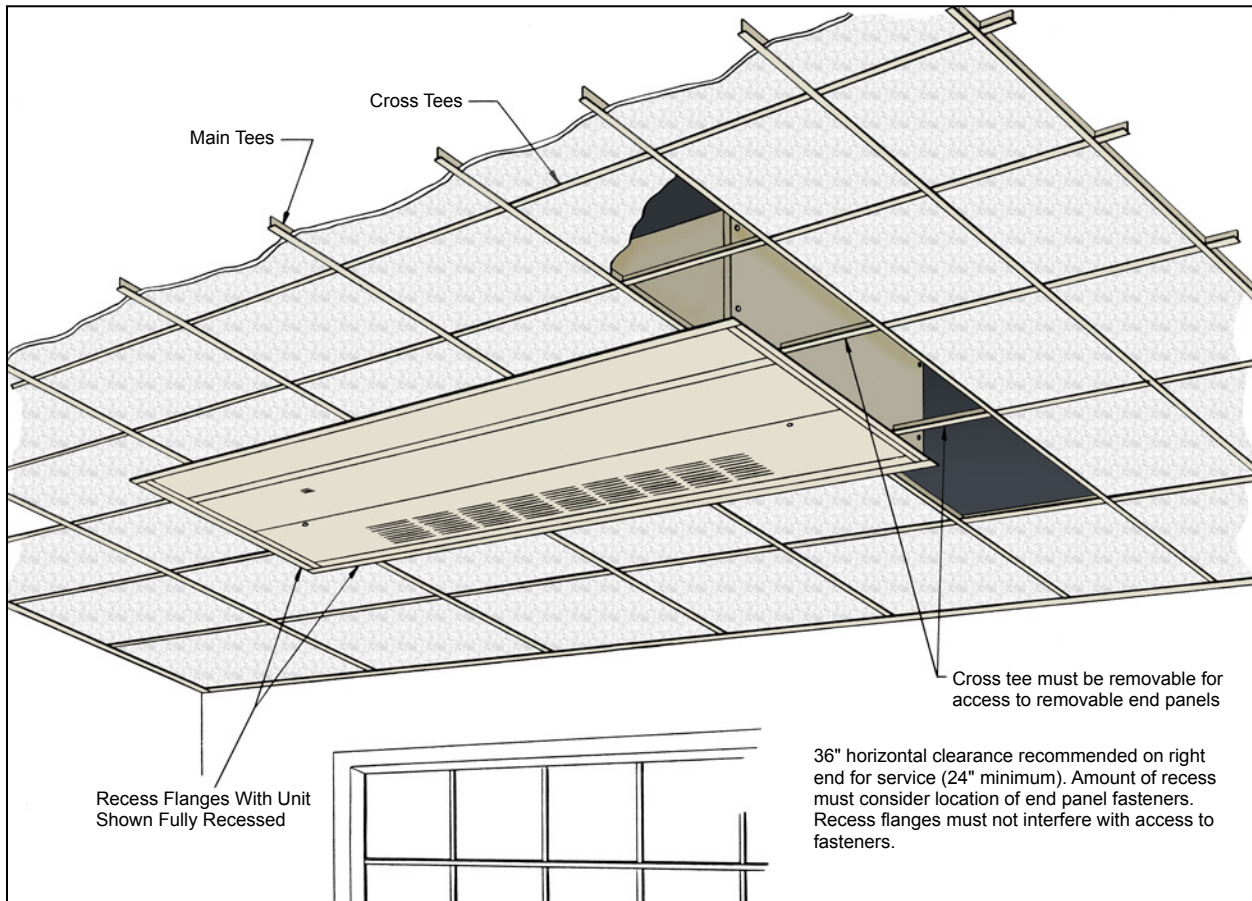

Unit Arrangements

Ceiling unit ventilation is typically applied to bring outside air directly to interior rooms or spaces of a school such as a computer teaching room, auditorium, gymnasium or library. The ceiling unit can be applied in a variety of applications; in a soffit, partially recessed, fully recessed and concealed. Units when correctly applied are capable

of operating against external statics up to 0.45 inches w.g. Flexible boots and ceiling are by others.

⚠ CAUTION

Avoid a rear outdoor return air arrangement, where strong prevailing winds have a direct path into the unit ventilator outdoor air opening. Strong air turbulence can cause undesirable sound levels, unit operating issues and property damage.

Completely Exposed Arrangements

Figure 111: 36" Units

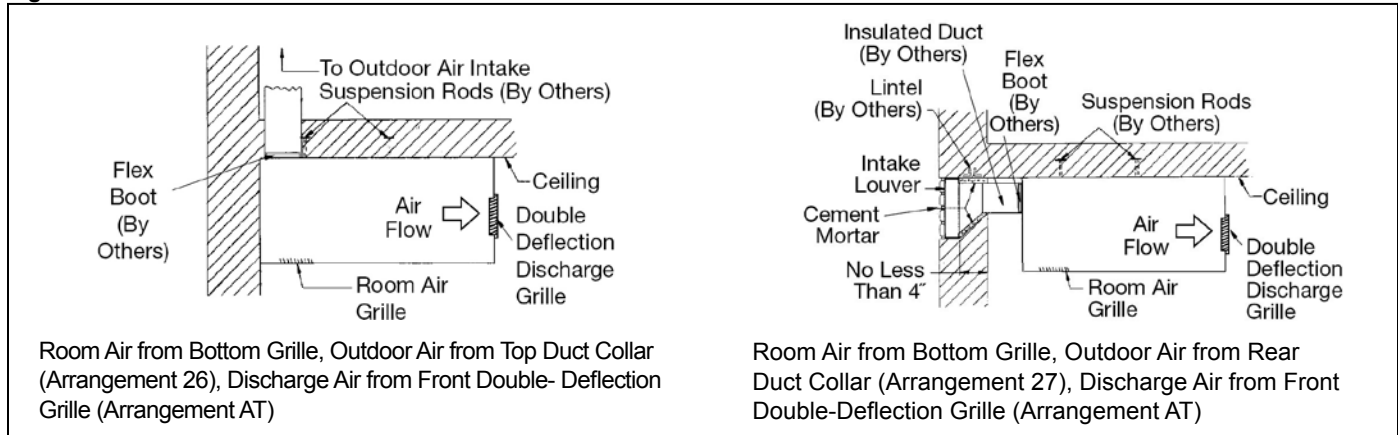
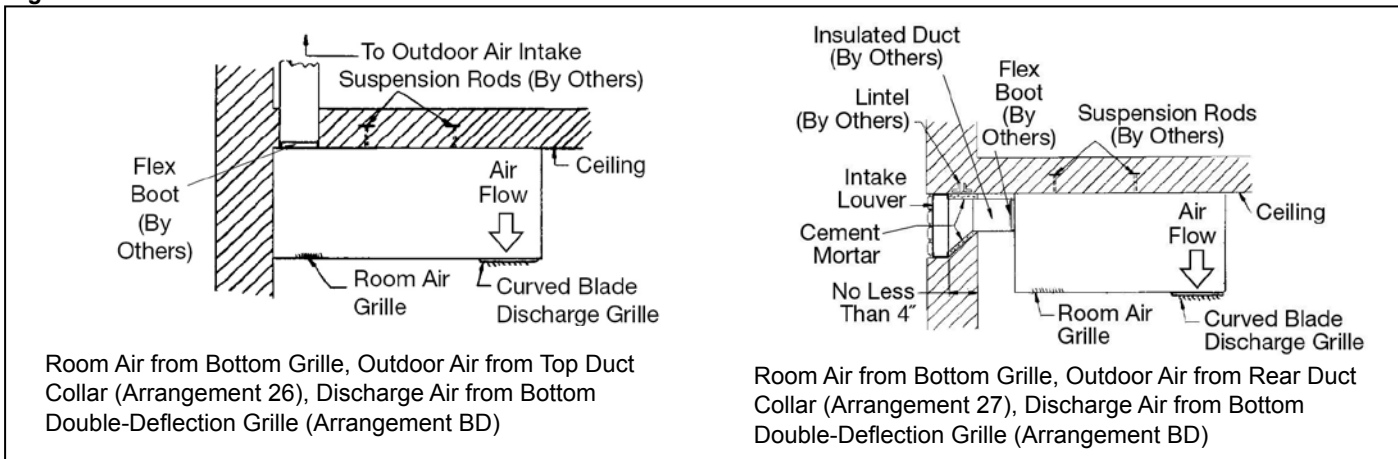

Figure 112: 40" Units



Partially Exposed (Soffit) Arrangements

Figure 113: 36" Units

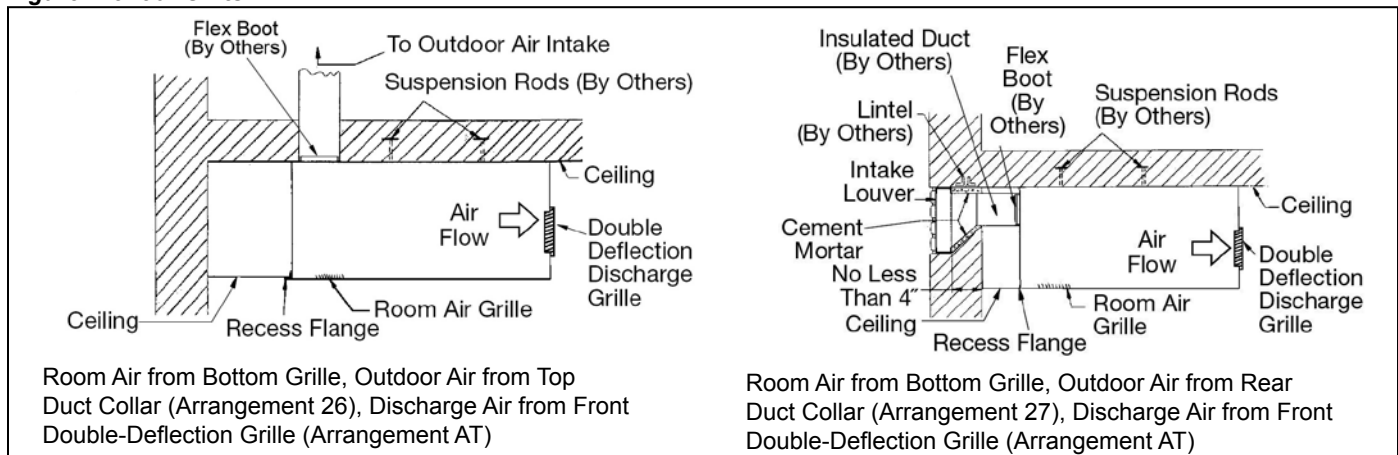
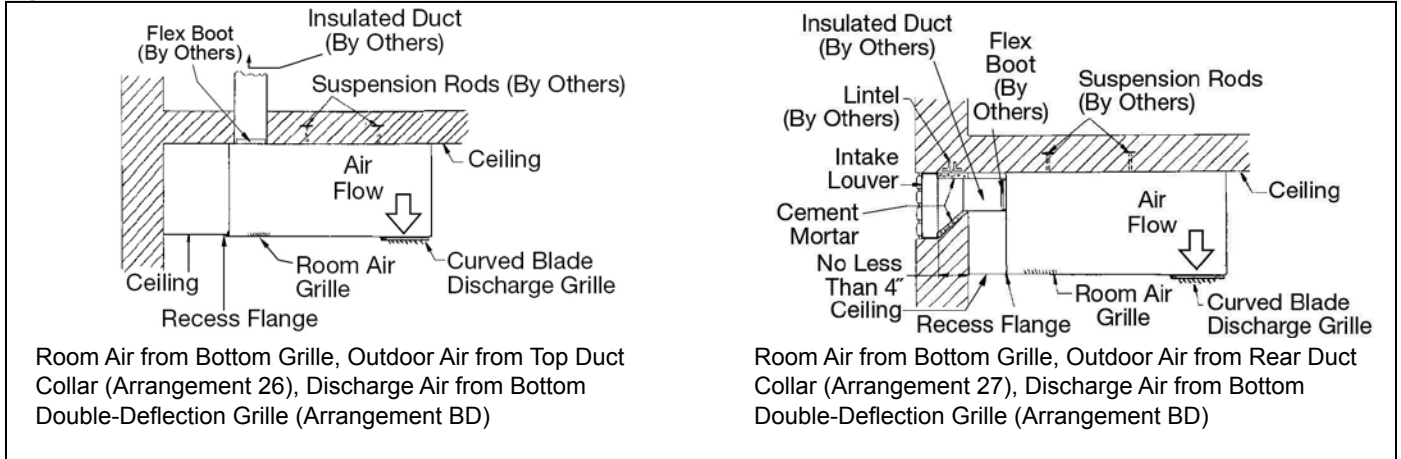

Figure 114: 40" Units



Fully Recessed Arrangement

Figure 115: 36" Units

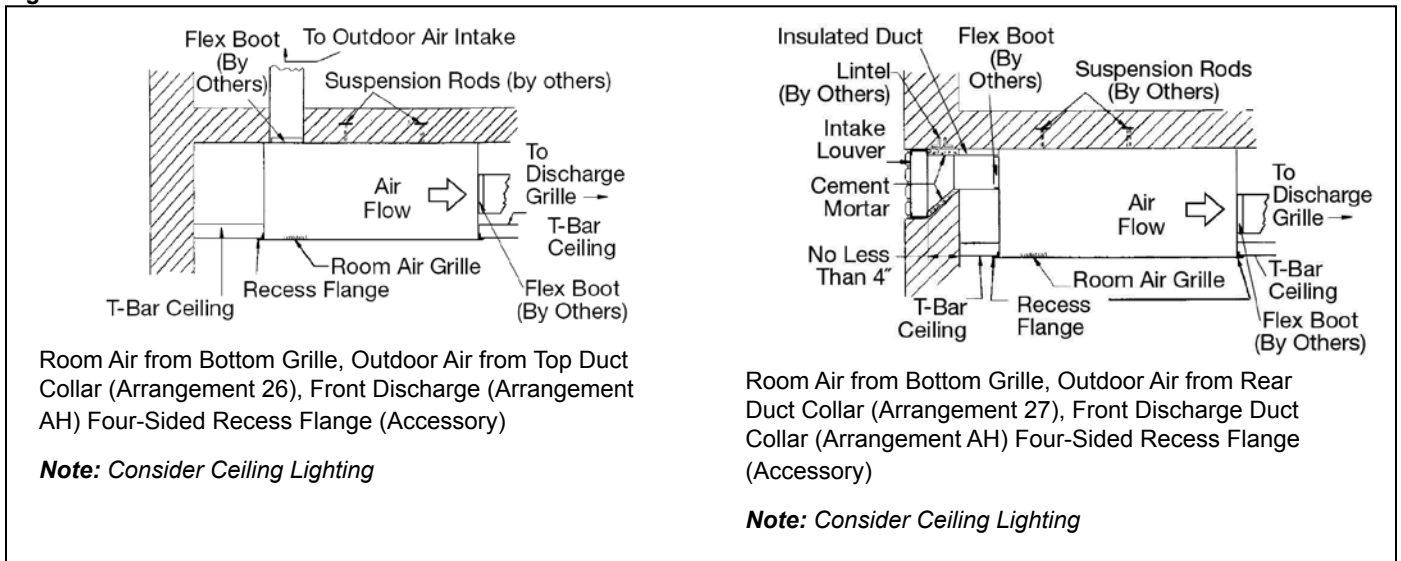
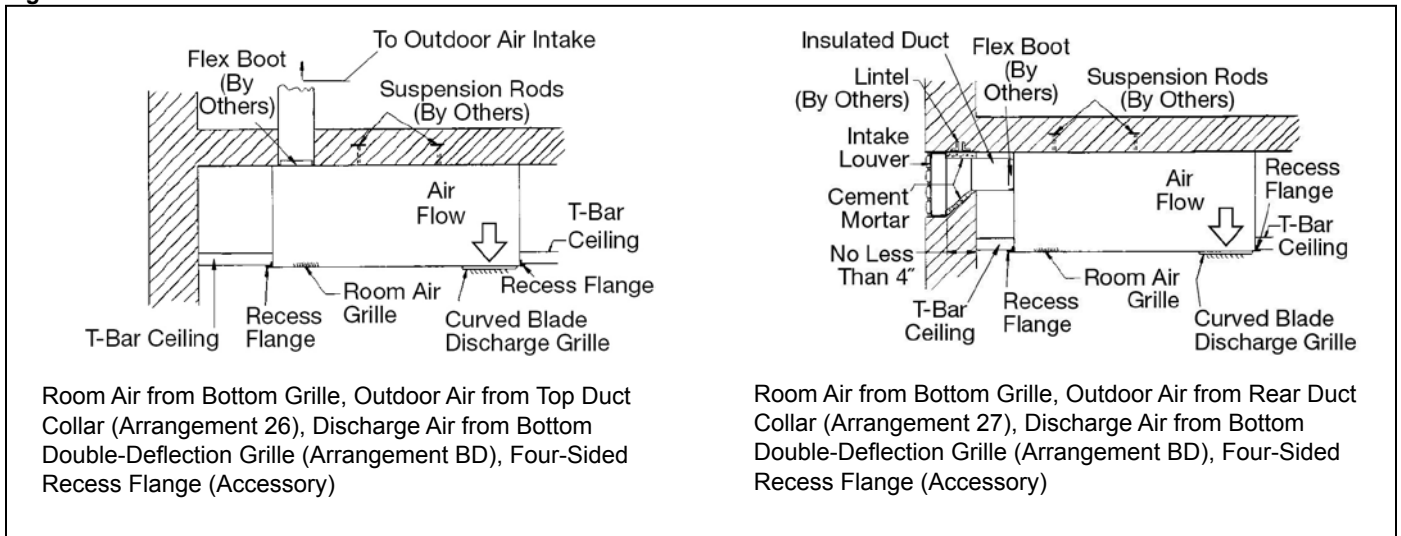

Figure 116: 40" Units



Concealed Arrangements

Figure 117: 36" Units

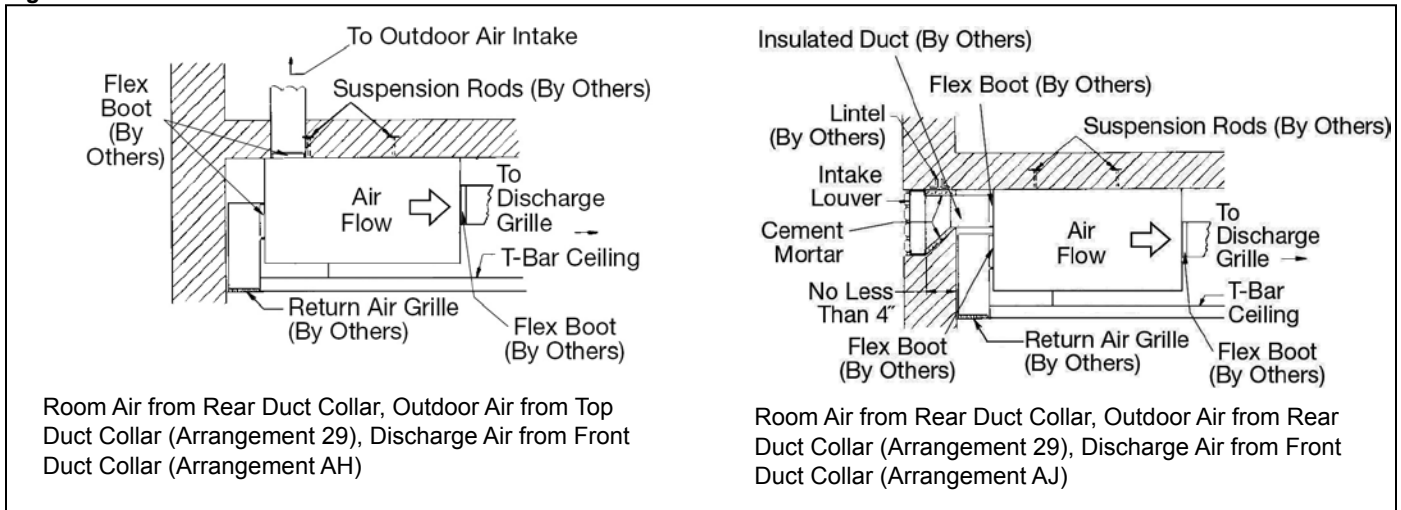
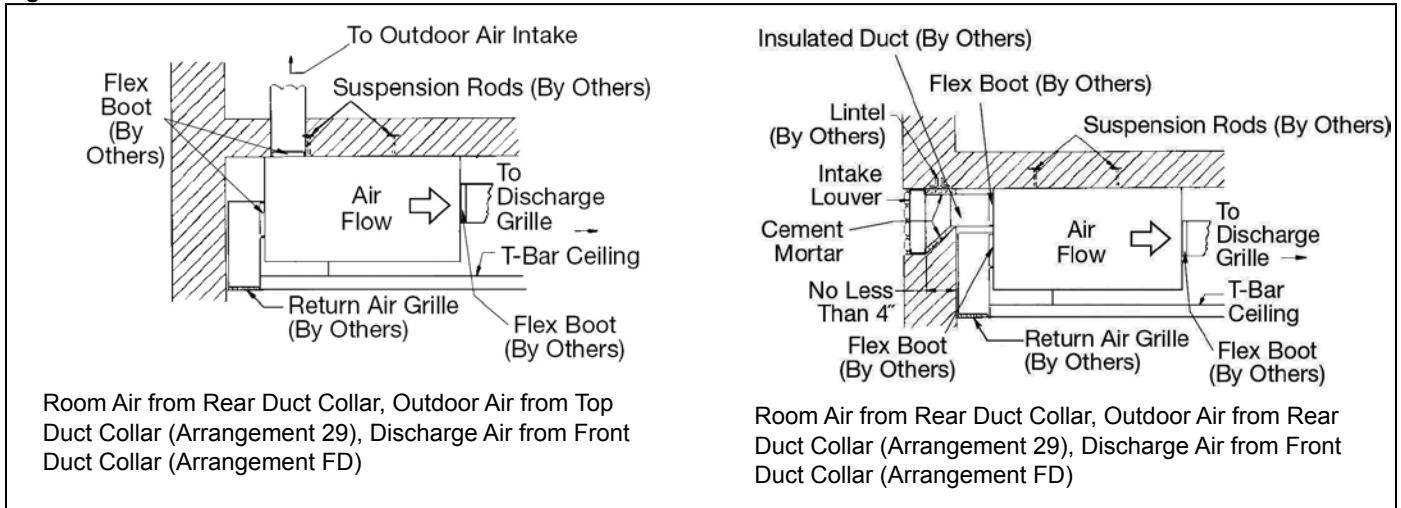

Figure 118: 40" Units



Duct System Applications

Duct work can be used with this unit for outdoor, return and discharge air, singly or in combination. It is designed to operate against external static pressures (ESP) through 0.45". ESP is determined by adding the discharge air static pressure, if any, to the greater of the outdoor or return air static pressure.

Duct System Design

Good duct design makes for a quiet installation that can positively impact a school for years. Flexible connections between the unit discharge, the unit return/outdoor air and any duct work should be provided using uniform straight flow conditions at the unit outlet and inlet. Accurate determination of resistance losses for the ductwork system is also necessary for satisfactory fan performance.

The following general suggestions are offered only to stress their importance; however, additional important factors must be considered. Assistance in the design of ductwork can be found in the ASHRAE Handbook and SMACNA publications, as well as other recognized authorities.

Duct Design For Noise Control

Proper acoustics are often a design requirement for schools. Most problems associated with HVAC generated sound can be avoided by properly selecting and locating system components. Figure 119, Figure 120 and Figure 121 on page 99 show suggested supply and return air duct considerations per SMACNA and ASHRAE. Here are some general do's and don'ts that should be observed to reduce the amount of sound that reaches the occupied room:

- Use flexible duct connections.
- Make the discharge duct the same size as the unit discharge opening for the first five feet.
- Line the first five feet of the supply and return ducts.
- Make two 90-degree turns in the supply and return air ducts.
- Keep duct velocity low and follow good duct design procedures.
- Mount and support the ductwork independent of the unit.
- Locate the return air intake away from the unit discharge.
- Provide multiple discharges.
- Restrict use of high-pressure-drop flexible ducting.
- Size the outdoor air and return air ducts to handle 100% of the total cfm to accommodate economizer or morning warm-up operation.

Figure 119: Suggested supply air ducting per ASHRAE and SMACNA publications

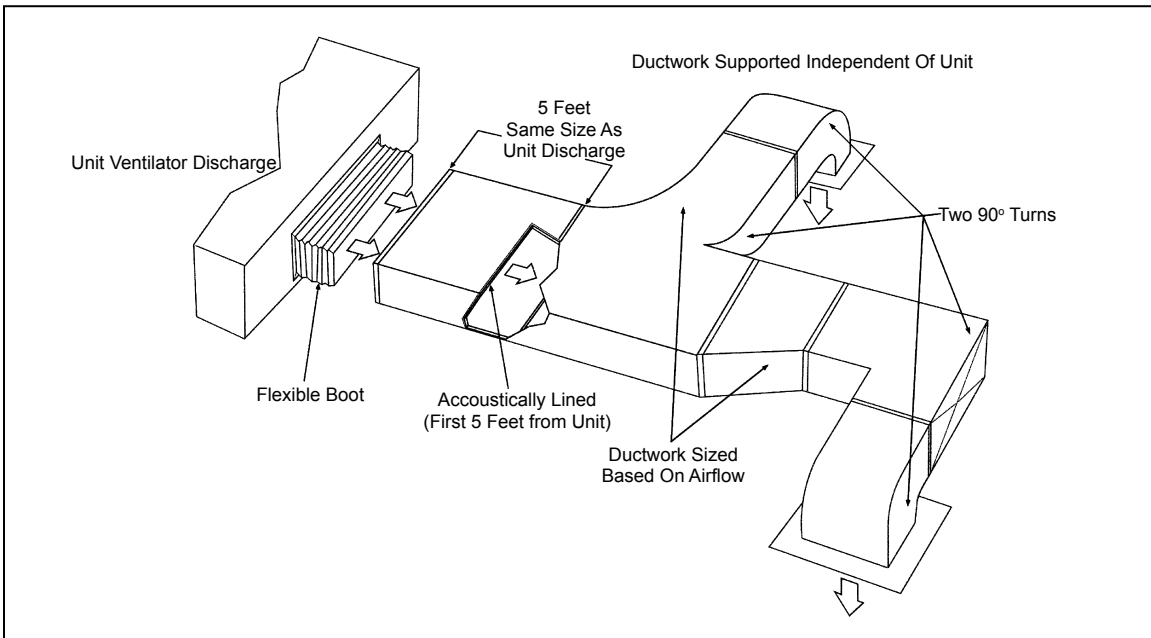

Figure 120: Suggested return air ducting per ASHRAE and SMACNA publications

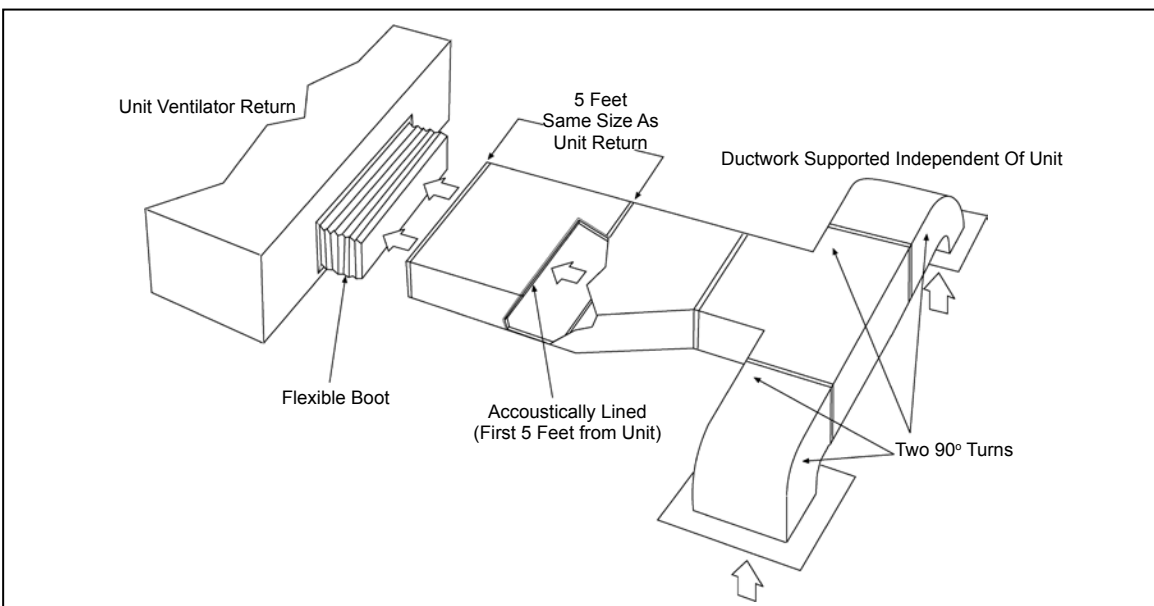
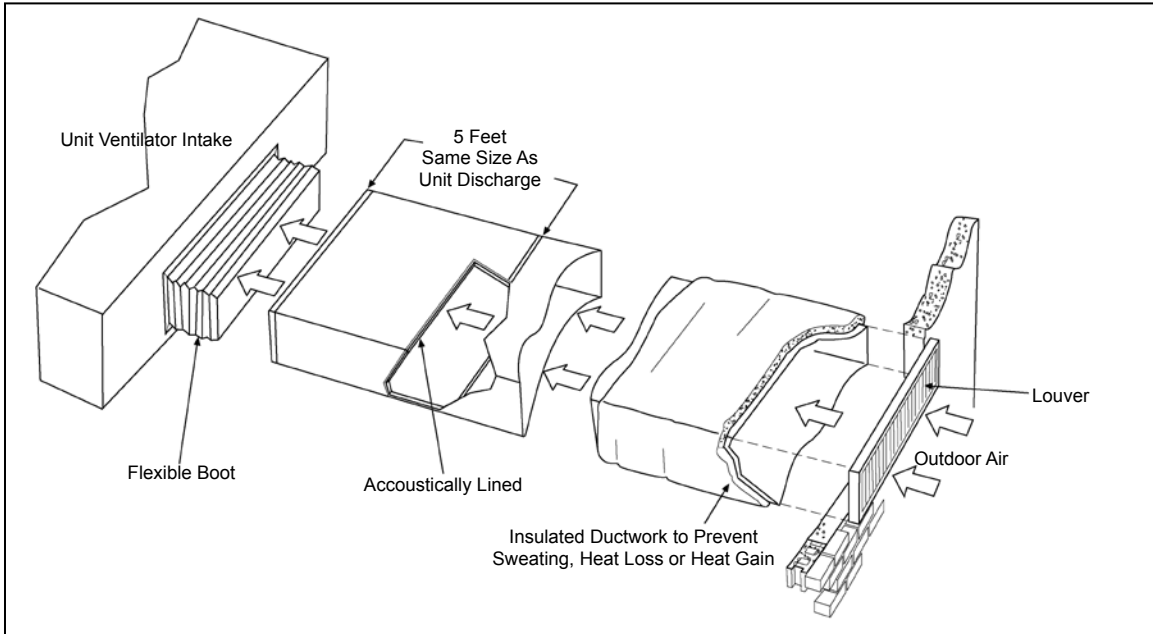

Figure 121: Suggested outdoor air ducting (insulated) per ASHRAE and SMACNA publications



⚠ CAUTION

Avoid a rear outdoor return air arrangement, where strong prevailing winds have a direct path into the unit ventilator outdoor air opening. Strong air turbulence can cause undesirable sound levels, unit operating issues and property damage.

Figure 122: Outdoor Air Arrangement With Prevailing Winds

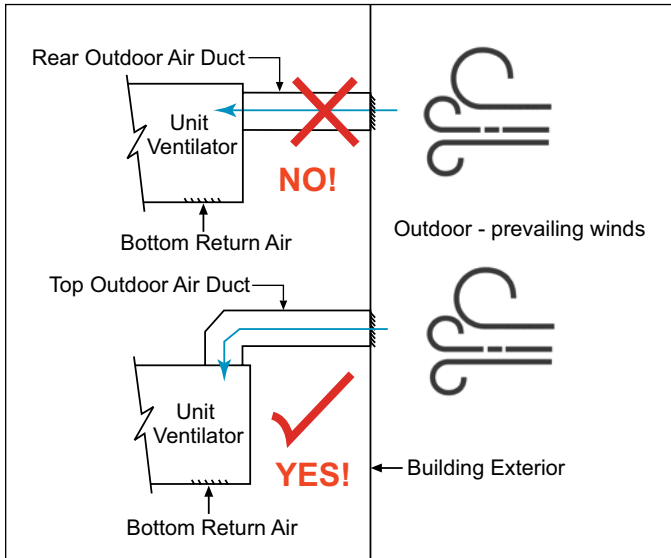

Wall Louvers

The outdoor air wall louver is usually set directly back of the unit ventilator. The position of the wall louver is determined in general by the building construction. The top of the lower channel of the louver frame should be at least 1/2" below the level of the inlet to the unit ventilator. However, if a high intake opening is necessary, the top of this opening should be not more than 28" above the surface upon which the unit ventilator will set.

Recessed Wall Louvers

Set recessed wall louvers into the wall in a bed of mortar with the face of the louver frame set slightly inside the wall line. The complete wall louver frame must be level with the face plumb and the louver frame set so that the drain holes on the bottom are toward the outside of the building.

The mortar should seal the frame perimeter water-tight to help prevent leaks. Do not block drain holes in the frame with mortar (Figure 123).

Figure 123: Recessed Wall Louver Installation Detail

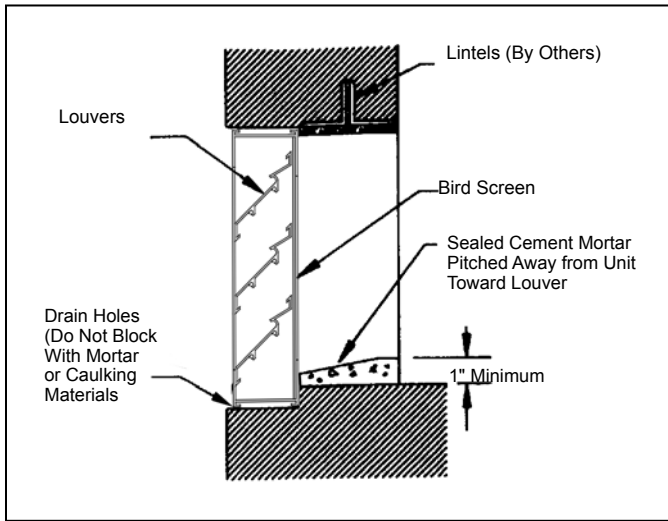

Flanged Wall Louvers

Set flanged wall louvers into the wall in a bed of mortar with the face of the louver frame flush with the wall line (Figure 124). The complete wall louver and frame must be set level. Do not block drain holes in the frame with mortar.

Use appropriate fasteners to secure the louver through the flange into the adjacent wall. Caulk the entire perimeter of the flange. For panel wall construction applications, caulk and seal the top and vertical sides of the vertical blade louver. Be sure that the drainage holes are pointing outward and that a metal channel is used to drain moisture (Figure 125).

Figure 124: Flanged Wall Louver Installation Detail

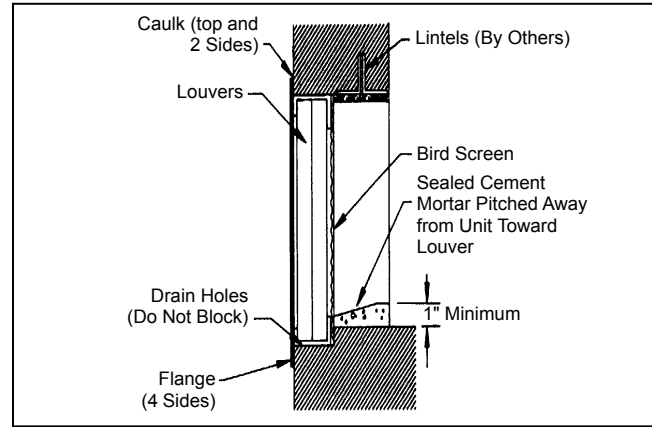
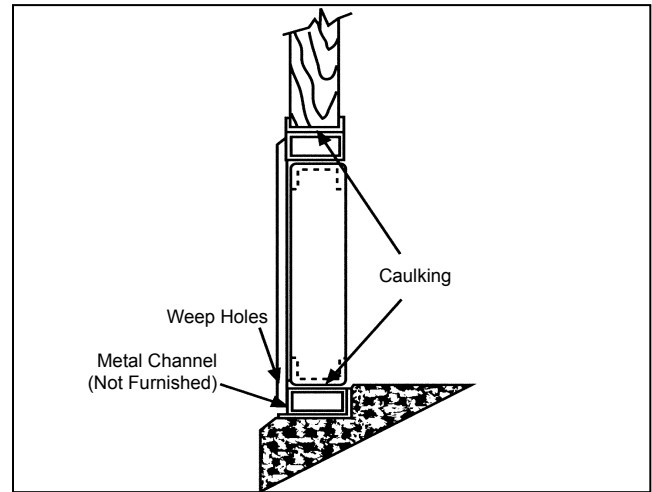

Figure 125: Panel Wall Louver Installation Detail



Lintels

When brickwork is built up to the top of the intake, lintels must be used above the wall louvers. While the wall is still wet, finish the brick on the top, bottom and both sides of the intake opening with 1/2" cement mortar. With the standard location of the wall louver, the bottom of the intake opening must slope from the louver frame up toward the intake opening to a point 1" above the finished base of the unit. This provides a surface against which the gasket at the bottom of the unit ventilator can be placed to help prevent any leakage of outdoor air under the unit.

If a metal sleeve connection is to be used between the unit ventilator and the wall louver, this sleeve must be installed after the unit ventilator is set, making a weather-tight connection to the unit ventilator cabinet. Turn the sleeve over the edge of the louver frame by proper peening before the louver is finally installed.

Interior Considerations

The interior wall surface behind the unit ventilator must be smooth and level. A wall that is slightly out of plumb can cause major problems with outside air leakage into the room and unit. This could cause drafts and potentially freeze coils.

Be certain that no gap is left between the unit and the outside air louver opening. Otherwise, outside air can leak into the room.

A rubberized, self-adhering membrane around the outside air opening can be used to seal any air or water leaks that might result from construction. Provide a seal under the unit to prevent air infiltration. In addition, seal the unit top and side perimeters to prevent unnecessary air infiltration due to uneven walls.

Indoor Air Exhaust Considerations

All outdoor air introduced by the unit ventilator must leave the room in some way. In some states, exhaust vents are required by law. In states where vents are not required by law, a decision must be made about how best to handle this problem.

The venting system chosen should have the ability to exhaust varying amounts of air equal to the amount of outside air introduced by the floor unit ventilator. A constant volume system, such as a powered exhaust, is unable to respond to changing conditions. It will either exhaust too much air, resulting in a negative pressure, which draws in more outdoor air than desired. Or, it will exhaust too little air, resulting in increased positive pressure, which restricts the amount of outside air being brought into the room.

The Daikin VentiMatic Shutter is a more economical solution to the problem. See "[VentiMatic™ Shutter – Room Exhaust Ventilation](#)" on page 26 for information on this system and its proper installation.

VentiMatic Installation

Figure 126: VentiMatic Shutter Components



Louver ships assembled as one piece

The VentiMatic Shutter should be mounted on the same wall as the unit ventilator. This neutralizes the effect of wind pressure forcing excess air into the room through the unit ventilator louver. That's because the wind pressure will also keep the VentiMatic Shutter closed and prevent room air from escaping. Since the existing room air cannot leave, excess air from the wind gust will not enter. (In contrast, a powered exhauster would "assist" the wind's effect.) Same-wall mounting also minimizes "short circuiting" of air flow that could occur with opposite-wall mounting.

The VentiMatic Shutter is generally mounted on a Daikin wall louver (ordered separately) which is then used for exhaust. For large unit ventilators, two VentiMatic Shutters may be mounted side by side on the same wall louver to promote adequate exhaust air capacity. The size and appearance of wall louvers and grilles used for unit ventilators and for VentiMatic Shutters are identical and present an architecturally coordinated and pleasing installation.

An ideal method of integrating the VentiMatic Shutter with the unit ventilator is to locate the shutter behind a matching open-shelf or closed-shelf storage cabinet mounted next to the unit ventilator. For example, 48-inch length wall louver can be accommodated behind a 4-foot high storage cabinet. The cabinet should be ordered with a slotted-type kick plate to provide a concealed exhaust air path to the shutter. This combination will enable a complete, integrated, energy-efficient HVAC and room exhaust system. For dimensional information, see "[VentiMatic Shutter Assembly](#)" on page 50.

Face and Bypass End-Of-Cycle Valve Sizing & Piping

MicroTech face and bypass damper control units require an end-of-cycle (EOC) valve for each hydronic coil. Unlike modulating valves that require precise control over the variable flow rate through the valve, the EOC valves are either full-open or full-closed, and therefore a proper valve Cv selection is not important. Table 52 gives the pressure drops at various water flow rates for the available EOC valves.

Select an EOC valve based on the application and type of coil to be controlled. For hydronic systems with constant flow pumps a 3-way valve is recommended, while 2-way valves are typically used on systems with

variable flow pumps. Each hydronic coil in the unit will require its own EOC valve. For hot water or 2-pipe chilled/hot water coils use a normally open valve, and for chilled water coils use a normally closed valve. The 3-way valves can be piped for normally open or normally closed duty (see Figure 127 on page 103) and it is very important that they are properly installed in the field for the MicroTech control sequence to function correctly. The Normally Open outlet port must be connected to hot water or 2-pipe chilled/hot water coils, and the Normally Closed outlet port must be connected to chilled water coils.

Table 52: Hot and Chilled Water End-Of-Cycle Valve Selection By Pressure Drop

| | | Valve Pressure Drop at Listed Water Flow Rate | | | | | | | | | | | | | | | | |
|--|-----------------|---|------|------|------|------|------|------|------|------|------|------|------|------|------|------|------|-------|
| Cv | Connection Size | GPM | 5 | 6 | 7 | 8 | 9 | 10 | 11 | 12 | 13 | 14 | 15 | 16 | 17 | 18 | 19 | 20 |
| | | L/s | 0.32 | 0.38 | 0.44 | 0.50 | 0.57 | 0.63 | 0.69 | 0.76 | 0.82 | 0.88 | 0.95 | 1.01 | 1.07 | 1.14 | 1.20 | 1.26 |
| 3-Way Hot or Chilled Water EOC Valve, FNPT | | | | | | | | | | | | | | | | | | |
| 5.0 | 3/4 inch | ft H2O | 2.3 | 3.3 | 4.5 | 5.9 | 7.5 | 9.2 | 11.2 | 13.3 | 15.6 | 18.1 | 20.8 | 23.6 | 26.7 | 29.9 | 33.3 | 36.9 |
| | | kPa | 6.9 | 9.9 | 13.5 | 17.7 | 22.3 | 27.6 | 33.4 | 39.7 | 46.6 | 54.1 | 62.1 | 70.6 | 79.7 | 89.4 | 99.6 | 110.3 |
| 2-Way Hot Water EOC Valve, FNPT, Normally Open / 2-Way Chilled Water EOC Valve, FNPT, Normally Open | | | | | | | | | | | | | | | | | | |
| 7.5 | 3/4 inch | ft H2O | 1.0 | 1.5 | 2.0 | 2.6 | 3.3 | 4.1 | 5.0 | 5.9 | 6.9 | 8.0 | 9.2 | 10.5 | 11.9 | 13.3 | 14.8 | 16.4 |
| | | kPa | 3.1 | 4.4 | 6.0 | 7.8 | 9.9 | 12.3 | 14.8 | 17.7 | 20.7 | 24.0 | 27.6 | 31.4 | 35.4 | 39.7 | 44.2 | 49.0 |
| 2-Way Hot Water EOC Valve, FNPT, Normally Open | | | | | | | | | | | | | | | | | | |
| 8.0 | 1 inch | ft H2O | 0.9 | 1.3 | 1.8 | 2.3 | 2.9 | 3.6 | 4.4 | 5.2 | 6.1 | 7.1 | 8.1 | 9.2 | 10.4 | 11.7 | 13.0 | 14.4 |
| | | kPa | 2.7 | 3.9 | 5.3 | 6.9 | 8.7 | 10.8 | 13.0 | 15.5 | 18.2 | 21.1 | 24.2 | 27.6 | 31.1 | 34.9 | 38.9 | 43.1 |

Figure 127: 3-Way Valve Piping Connections

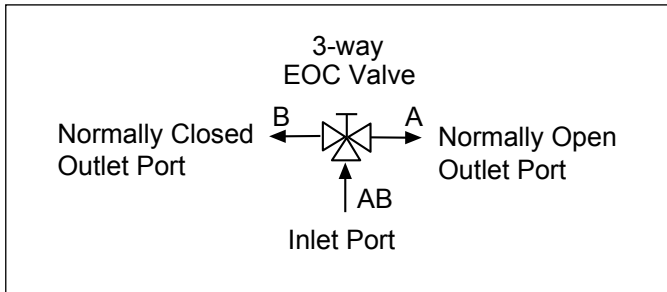

Hot Water EOC Valve Piping

Hot water (or chilled water/hot water 2-pipe) EOC valves are furnished normally open to the coil. When the valve is de-energized (off) there is full flow through the coil. Energizing the valve shuts off the water flow.

Figure 128: 2-Way Hot Water EOC Valve Piping

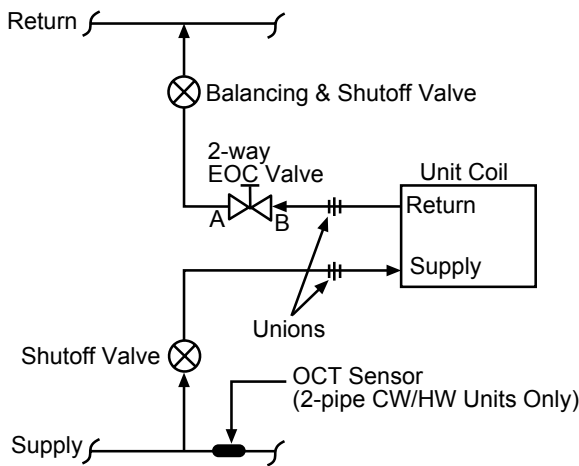
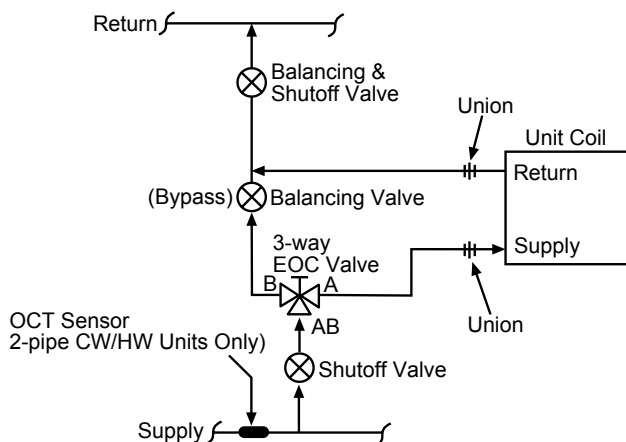

Figure 129: 3-Way Hot Water EOC Valve Piping



Chilled Water EOC Valve Piping

Chilled water EOC valves are furnished normally closed to the coil. When the valve is de-energized (off) there is no flow through the coil. Energizing the valve allows flow through the coil.

Figure 130: 2-Way Chilled Water EOC Valve Piping

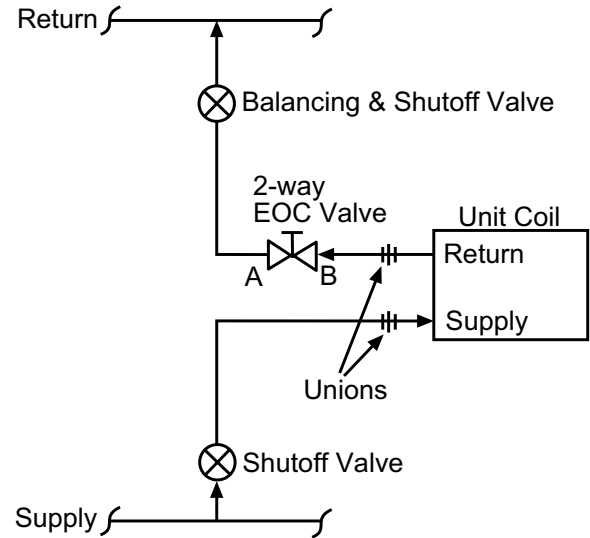
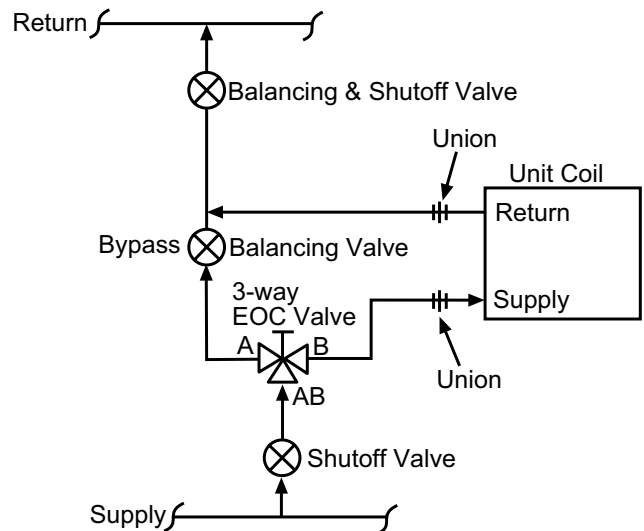

Figure 131: 3-Way Chilled Water EOC Valve Piping



Modulating Valve Sizing & Piping

The unit ventilator control valve is expected to vary the quantity of water that flows through the coil in a modulating fashion. Movement of the valve stem should produce a controlled change in the amount of water that flows through the coil. When control valves are oversized (Cv too high) the flow relative to valve position is not linear. For example, assume that when the control valve is fully open, the pressure drop through the coil is twice as great as the drop through the valve. In this case, the control valve must travel to approximately 50% closed before it can begin to have any influence on the water flow through the coil. The control system, no matter how sophisticated, cannot overcome this. Oversized control valves can also result in hunting which will shorten the life of the valve and actuator and possibly damage the coil. Undersized (Cv too low) control valves will accurately control the flow but will have a very high pressure drop through the valve.

To correctly select the modulating valve:

1. Determine the flow of water and the corresponding pressure drop through the coil.
2. Obtain the pressure difference between the supply and return mains.
3. Select a valve (Cv) from [Table 53](#) on the basis of taking 50% of the available pressure difference (at design flow) between the supply and return mains at the valve location. The valve should have a pressure drop greater than that of the coil. Whenever possible there should be at least 11 feet of water (5psi) (32.9 kPa) pressure drop across the valve.

Modulating valves for water applications can be either 2-way or 3-way. Refer to the modulating valve label to determine the direction of flow. The modulating valve must be installed on the unit for which it was selected.

The modulating valve furnished for steam applications is a 2-way, normally open to the coil configuration (see ["Modulating Steam Valve Selection"](#) on page 106 for application).

Table 53: 2-Way Modulating Valve 1/2" – Pressure Drop

| 2-Way CCV Part No. | Cv Maximum Rating | Connection Size | Pressure Drop Across the Valve | | | | | | | | | |
|--------------------|-------------------|-----------------|--------------------------------|-------|-------|-------|-------|-------|-------|-------|-------|--------|
| | | | 1 PSI | 2 PSI | 3 PSI | 4 PSI | 5 PSI | 6 PSI | 7 PSI | 8 PSI | 9 PSI | 10 PSI |
| B209 | 0.8 | 1/2 inch | 0.8 | 1.1 | 1.4 | 1.6 | 1.8 | 2.0 | 2.1 | 2.3 | 2.4 | 2.5 |
| B210 | 1.2 | | 1.2 | 1.7 | 2.1 | 2.4 | 2.8 | 2.9 | 3.2 | 3.4 | 3.6 | 3.8 |
| B211 | 1.9 | | 1.9 | 2.7 | 3.3 | 3.8 | 4.2 | 4.7 | 5.0 | 5.4 | 5.7 | 6.0 |
| B212 | 3.0 | | 3.0 | 4.2 | 5.2 | 6.0 | 6.8 | 7.3 | 7.9 | 8.5 | 9.0 | 9.5 |
| B213 | 4.7 | | 4.7 | 6.6 | 8.1 | 9.4 | 11 | 12 | 12 | 13 | 14 | 15 |
| B214 | 7.4 | | 7.4 | 10 | 13 | 15 | 17 | 18 | 20 | 21 | 22 | 23 |

Table 54: Modulating 3-Way Hot Water, Chilled Water or 2-Pipe CW/HW Valve 1/2" – Pressure Drop

| 2-Way CCV Part No. | Cv Maximum Rating | Connection Size | Pressure Drop Across the Valve | | | | | | | | | |
|--------------------|-------------------|-----------------|--------------------------------|-------|-------|-------|-------|-------|-------|-------|-------|--------|
| | | | 1 PSI | 2 PSI | 3 PSI | 4 PSI | 5 PSI | 6 PSI | 7 PSI | 8 PSI | 9 PSI | 10 PSI |
| B309(B) | 0.8 | 1/2 inch | 0.8 | 1. | 1.4 | 1.6 | 1.8 | 2.0 | 2. | 2.3 | 2.4 | 2.5 |
| B310(B) | 1.2 | | 1.2 | 1.7 | 2. | 2.4 | 2.8 | 2.9 | 3.2 | 3.4 | 3.6 | 3.8 |
| B311(B) | 1.9 | | 1.9 | 2.7 | 3.3 | 3.8 | 4.2 | 4.7 | 5.0 | 5.4 | 5.7 | 6.0 |
| B312(B) | 3.0 | | 3.0 | 4.2 | 5.2 | 6.0 | 6.8 | 7.3 | 7.9 | 8.5 | 9.0 | 9.5 |
| B313(B) | 4.7 | | 4.7 | 6.6 | 8.1 | 9.4 | 11 | 12 | 12 | 13 | 14 | 15 |
| B318(B) | 7.4 | | 7.4 | 10 | 13 | 15 | 17 | 18 | 20 | 21 | 22 | 23 |

Hot Water Modulating Valve Piping

Modulating hot water (or 2-pipe CW/HW) valve is furnished to fail open to the coil. 24VAC is required to power the valve actuator. When the actuator is powered, a controller will provide a 2-10VDC signal to the actuator. A signal of 2VDC or less will drive the valve closed; the valve will drive open as the signal increases to a maximum of 10VDC.

If 24VAC is lost to the actuator, valve will spring-return to its fail position (open to the coil for hot water or 2-pipe CW/HW valves).

Figure 132: 2-Way Hot Water Modulating Valve Piping

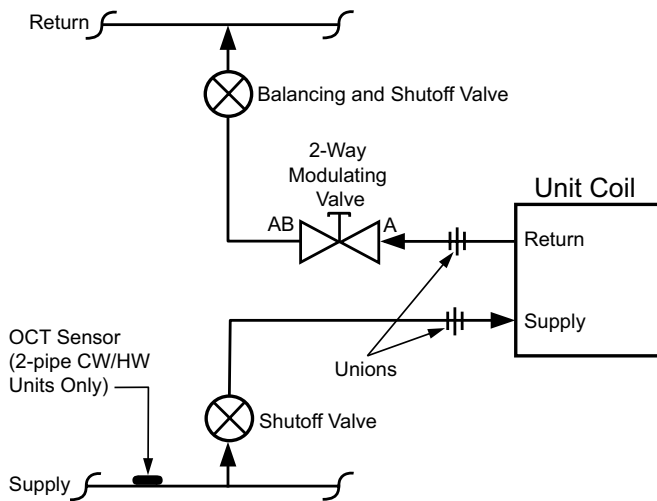

Note: Actuator to be configured for A port to be normally open.

Figure 133: 3-Way Hot Water Modulating Valve Piping

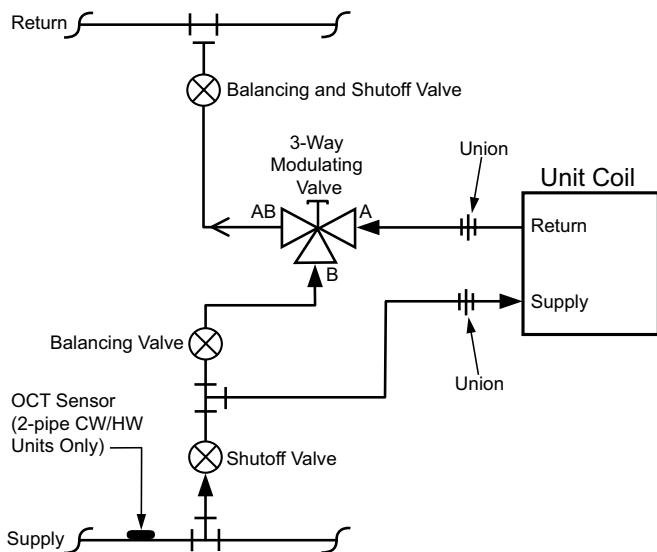

Note: The A port is always piped to the coil. Actuator to be configured for A port to be Normally Open.

Chilled Water Modulating Valve Piping

Modulating chilled water valve is furnished to fail closed to the coil. 24VAC is required to power the valve actuator. When the actuator is powered, a controller will provide a 2-10VDC signal to the actuator. A signal of 2VDC or less will drive the valve closed; the valve will drive open as the signal increases to a maximum of 10VDC.

If 24VAC is lost to the actuator, valve will spring-return to its fail position (closed to the coil for chilled water valves).

Figure 134: 2-Way Chilled Water Modulating Valve Piping

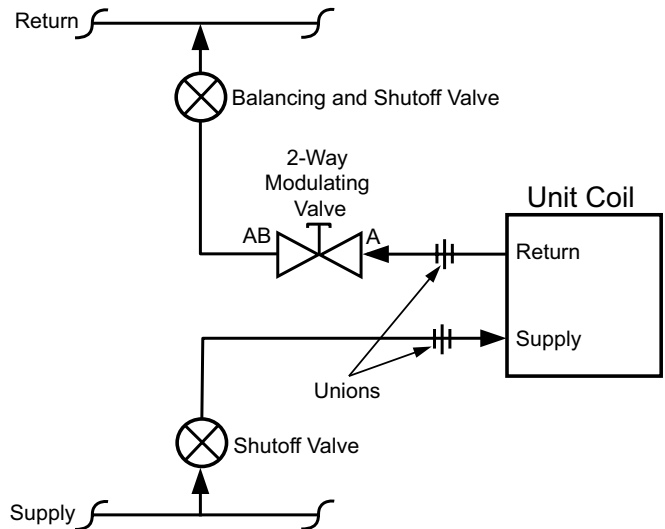

Note: Actuator to be configured for A port to be normally closed.

Figure 135: 3-Way Chilled Water Modulating Valve Piping

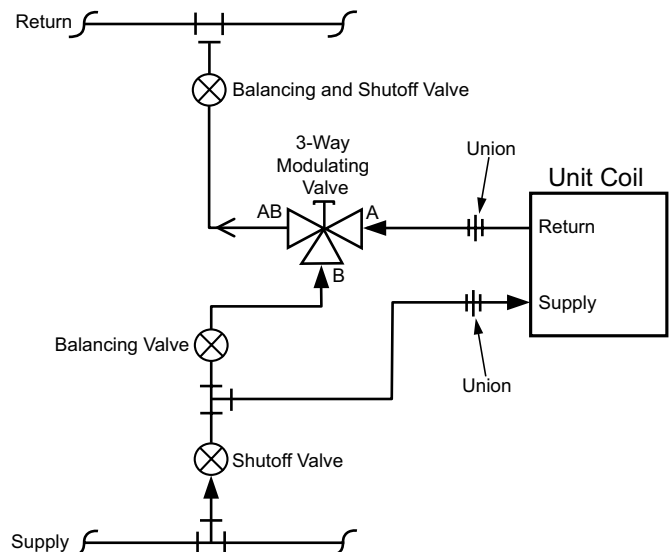

Note: The A port is always piped to the coil. Actuator to be configured for A port to be Normally Closed.

Steam Valve Sizing & Piping

End-Of-Cycle Steam Valve Selection

End-of-cycle, steam valves are either full-open or full-closed. To select an end-of-cycle steam valve:

1. Obtain the supply steam inlet pressure.
2. Determine the actual heat requirement of the space to be heated.
3. Select a steam valve (Cv) based on taking 10% of the inlet steam pressure. For example, for a system with an inlet pressure of 2 psig, the valve should be sized based on a 0.2 psig pressure drop. The valve must have a capacity greater than or equal to that of the space to be heated.

Table 55 gives the steam capacity based on a pressure drop equal to 10% of the inlet pressure.

Table 55: EOC Steam Valve Selection

| Cv | Connection Size | psig | 1 | 2 | 3 | 4 | 5 | 6 |
|---------------------------|-----------------|-------|-------|-------|-------|-------|-------|-------|
| | | kPa | 6.9 | 13.8 | 20.7 | 27.6 | 34.5 | 41.4 |
| EOC Steam Valve Selection | | | | | | | | |
| 8.00 | 1 inch | MBh | 34.3 | 50.0 | 63.0 | 74.7 | 85.6 | 96.0 |
| | | Watts | 10065 | 14660 | 18461 | 21886 | 25090 | 28148 |

¹ Based on 1150 Btu/lb of steam

Modulating Steam Valve Selection

The steam modulating control valve is expected to vary the quantity of steam through the coil. Any movement of the valve stem should produce some change in the steam flow rate. To select a modulating steam valve:

1. Obtain the supply steam inlet pressure.
2. Determine the actual heat requirement of the space to be heated.
3. Select a valve (Cv) from Table 56, which gives the capacity range based on a 60% pressure drop at the low end of the range and 100% pressure drop at the high end of the range.

For example: With 2 psig (13.8 kPa) inlet pressure, the valve with port code 4, in the full open position, would have a 1.2 psig (8.3 kPa) pressure drop (60% of 2 psig) at 65 MBh (19,189 watts) and a 2 psig pressure drop at 82 MBh (24,125 watts). The valve should have a capacity less than or equal to the space to be heated.

Table 56: 2-Way Modulating Steam Valve 1/2" – Pressure Drop

| 2-Way CCV Part No. | Cv Maximum Rating | Connection Size | Pressure Drop Across the Valve | | | | | |
|--------------------|-------------------|-----------------|--------------------------------|--------|--------|--------|--------|--------|
| | | | 2 PSI | 3 PSI | 4 PSI | 5 PSI | 10 PSI | 15 PSI |
| B215HT073 | 0.73 | 1/2" | 10.99 | 13.71 | 16.11 | 18.33 | 28.03 | 36.74 |
| B215HT186 | 1.86 | | 22.34 | 34.93 | 41.06 | 46.70 | 71.42 | 93.60 |
| B215HT455 | 4.55 | | 54.65 | 85.44 | 100.43 | 114.24 | 174.72 | 228.97 |
| B220HT731 | 7.31 | 3/4 inch | 110.02 | 137.27 | 161.36 | 183.54 | 280.70 | 367.86 |

Steam Valve Piping

End-of-cycle (EOC) and modulating valves for steam applications are 2-way, fail-open (on loss of 24v power), angle pattern valves. Energizing the EOC valve shuts off the flow of steam to the coil. For modulating valves, a signal of 2VDC or less will drive the valve closed; the valve will drive open as the signal increases to a maximum of 10VDC.

If 24VAC is lost to the actuator, valve will spring-return to its fail position (open to the coil for steam valves). Refer to the steam valve label to determine the direction of flow. The steam valve must be installed on the unit for which it was selected.

All valves are shipped loose to help prevent shipping damage and to provide the installing contractor with maximum flexibility in making the field piping connection. The valves are field piped by others. They are factory wired for field hook-up.

- Notes:**
1. Refer to the label furnished on 2-way valves to determine direction of flow through the valve.
 2. The control valve must be installed on the unit in which it was shipped. Indiscriminate mixing of valves among units can result in valves not properly sized for the desired flow rate.
 3. The control valve should be installed so that there is 2" (51mm) minimum clearance to remove the actuator from the valve body. Provide unions for the removal of the unit coil and/or control valve. This is a future service consideration.

Figure 136: 2-Way Steam End of Cycle Valve Piping

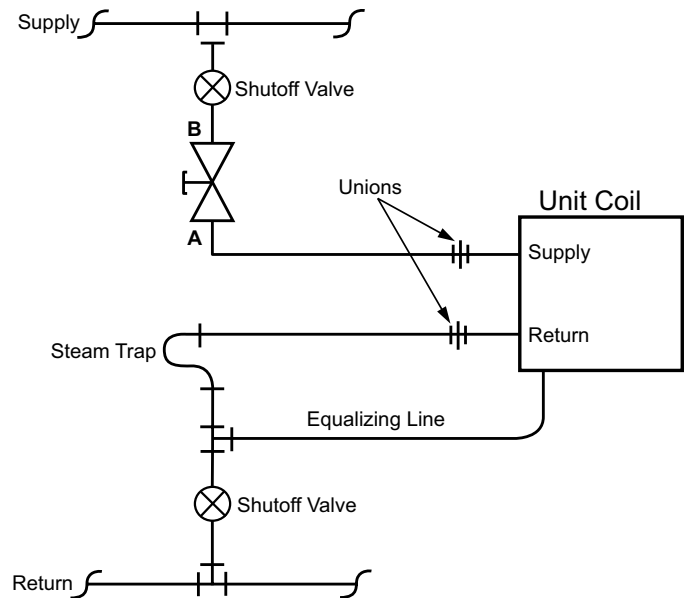

Note: For Erie EOC steam valves, always have the direction of steam flow piped to the B port of the valve. Actuator to be configured for B port to be normally open.

Figure 137: 2-Way Steam Modulating Valve Piping

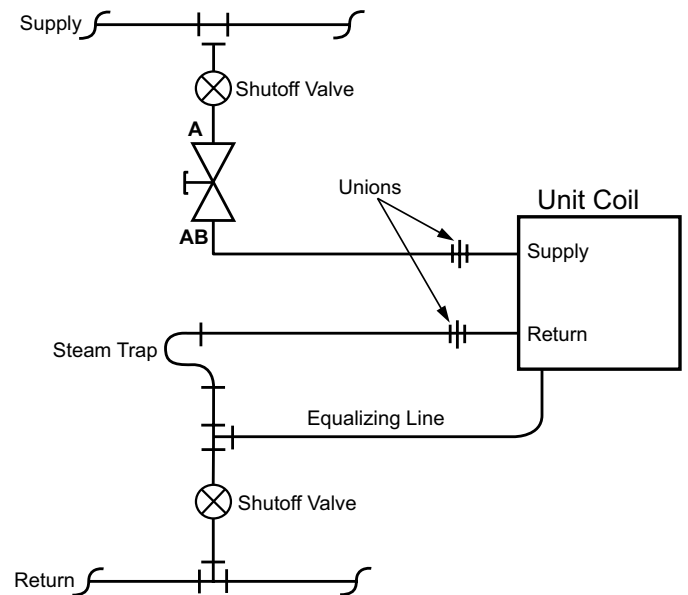

Note: For Belimo steam valves, always have the direction of steam flow piped to the A port of the valve. Actuator to be configured for A port to be normally open.

Daikin Applied Unit Ventilator – Model AH Guide Specifications

General

Furnish and install where shown on plans, a complete unit ventilator with capacities, airflow, and configuration as listed on unit schedule.

Unit Construction

All internal sheet metal parts must be made of galvanized steel to inhibit corrosion. The entire frame must be welded construction to provide strength and rigidity. Hidden reinforced top panel support shall be integral with the frame and support the fan assembly. Frames assembled with sheet metal fasteners shall not be acceptable. Unit shall be of a draw-thru design. Blow-thru design is not acceptable. Unit shall have a built-in metal wire raceway from one end compartment to the other.

Cabinets

Exterior cabinet panels shall be constructed of heavy-gauge steel. All sheet metal panels must be cleaned and phosphatized, then painted electrostatically with an oven baked environmentally friendly thermosetting urethane powder finish. The color shall be off-white.

Ceiling Units

The unit shall be of modular construction so that the fan, coil and damper sections are removable for service and maintenance

Three bottom panels, two of which are hinged, shall be provided for ease of service access and handling.

Retainer chains shall be provided to prevent sudden release of the hinged bottom panels. End panels shall be secured to the unit with recessed, tamper resistant, Allen head fasteners. Slots for flat head screwdrivers shall not be acceptable as tamper resistant.

Ceiling mounted units shall have a built-in metal wire raceway from right end compartment to left end compartment to contain any line voltage electrical wiring separate from the air stream. Line voltage wiring shall not be touchable in the air stream of the unit during normal maintenance procedures of oiling bearings or motors.

The discharge opening of the unit shall be fitted with:
SELECT one:

- a. an adjustable four-way deflection grille with the outer blades horizontal.
- b. a duct collar.

A ceiling trim flange shall be provided for recessed units. The trim flange shall be 3-sided or 4 sided as required.

The center line of the cooling condensate drain shall be a minimum of 4-3/4" above the bottom of the unit, to allow for appropriate trapping of the condensate disposal line.

Room Air Fans And Motor

The unit fan and motor assembly shall be of a modular construction so that it is removable from the bottom for service, maintenance and access to the coil section for cleaning. The motor and fan assembly shall be low speed design to assure maximum quietness and efficiency. Fans shall be double inlet, forward curved centrifugal type with offset aerodynamic blades. Assembly shall be statically and dynamically balanced. Fan housings shall be steel construction, incorporating logarithmic expansion for quieter operation. Fan shaft shall be 1-1/4" diameter hollow steel with 1-1/4" end bearing. Fan and motor assembly shall be direct drive type. Motor speed shall be controlled by factory mounted multi-tap transformer for High-Medium-Low-Off speeds. Fan/coil arrangement shall be draw-thru design for uniform coil face velocity and discharge air temperature. Motors shall be Electrically Commutated Motor (ECM) plug-in type, designed specifically for unit ventilator operation. Motors shall be located out of the airstream and have an internal thermal overload device (auto reset). Fan motors and controls shall have each hot line protected by factory installed cartridge type fuse(s). Motors shall have permanently lubricated bearings. Fan shaft may have sleeve type bearing that requires oiling no more than once annually. Units requiring oiling will have an oil cap accessed from the left-side end compartment (or on the middle of the fan shaft on size 1500cfm and larger). Some units are built with permanently sealed bearings that do not require oiling. Check for oil cap to determine which bearing type is present. Units shall have shaft bearing located out of the air stream. Bearings in the airstream are not acceptable.

Face And Bypass Damper

Each unit shall be provided with a factory-installed face and bypass damper, constructed of aluminum. The long sealing edges of the damper shall have silicone rubber impregnated cloth seals for long life and positive sealing. Face and bypass damper stops not fitted with seals shall not be acceptable. The damper ends shall have blended mohair seals glued along the ends for a positive seal. Plastic clip-on brush end seals will not be acceptable. The unit design shall incorporate the face and bypass damper to prevent coil surface wiping and be before the fan in a draw through configuration. Face and bypass damper positioned in the direct discharge of the room fan is not acceptable. The face and bypass damper shall be arranged so a dead air space results between the coil and the damper in a full bypass condition to minimize heat pick up.

Outdoor And Room Air Dampers

Each unit shall be provided with separate room air and outdoor air dampers. The room air damper shall be constructed of aluminum using metal-forming techniques to resist twisting and shall be counterbalanced against back pressure. Outdoor air damper shall be two-piece double-wall construction with 1/2" thick, 1.5 lbs. density fiberglass insulation encapsulated between welded 20 ga. galvanized steel blades for rigidity and to inhibit corrosion, and have additional insulation on the exterior surfaces of the damper blade and on the ends of the outdoor air chamber. Dampers shall be fitted with mohair seals along all the sealing edges.

Dampers shall use turned-metal principle on long closing ends with no metal-to-metal contact. No plastic or rubber gaskets shall be acceptable. Damper bearings shall be made of nylon or other material which does not require lubrication.

Drain Pan

All units shall come furnished with an insulated drain pan constructed of galvanized steel. A drain outlet shall be provided on both ends of the pan. The drain hand of connection shall be easily field-reversed to the opposite end. The drain pan shall be able to be sloped in either direction for proper condensate removal. [Option: Drain pan shall be constructed of stainless steel.]

Agency Listing

Unit ventilators shall be listed by Underwriters Laboratories Inc. (U.L.) for the United States and Canada. Unit ventilation rate to be certified and tested per Air Conditioning, Heating and Refrigeration Institute (AHRI) standard 840. All units with chilled water coils shall be AHRI certified for performance. Motors shall conform to the latest applicable requirements of NEMA, IEEE, ANSI, and NEC standards.

Coils

All hydronic coils shall be constructed with copper tubes and mechanically bonded aluminum corrugated plate fins. All coils shall have aluminum individual un-shared fin surfaces. An air brake shall exist between coils. Water coils shall be furnished with a threaded drain plug at the lowest point. A manual air vent shall be provided at the high point of the coil. Steam coils shall be double tube, steam distributing freeze-resistant type. Steam coils shall be furnished with a factory installed pressure equalizing device (vacuum breaker) to prevent the retention of condensate in the coil. Tubing shall be provided for field connection to the return line beyond the trap. Direct expansion coils (DX) – all DX coils must be supplied with factory-installed thermal expansion valve and a DX low temperature limit. This expansion valve must be sized for the manufacturer's matching remote condensing unit. Electric heat coils shall be open wire. Cal rods inserted into a tube shall not be acceptable.

Filters

Filter shall be one-piece design located to provide filtration of the outdoor air/return air mixture to assure even dust loading and balanced airflow in lieu of separate filters for outdoor air and return. [Throwaway filter (all except electric heat)] [wire, mesh, permanent filter (electric heat units)] shall be factory furnished initially installed in all units.

[Option: Furnish _____ extra set(s) of throwaway filters.]

[Option: Furnish one set of wire mesh permanent filters as final filter.]

[Option: Furnish one set of renewable (structural painted metal frame with glass fiber media) filters as final filter.]

Condensing Units

Condensing unit sizes shall be specifically matched to the unit ventilator size. The remote condensing unit shall be U.L. listed with brass service valves, internal high pressure control, low ambient air temperature thermostat. Sweat type tubing connections shall be furnished. The installing contractor shall provide interconnecting copper tubing of the size recommended by the condenser manufacturer. The installing contractor shall charge the system with refrigerant in accordance with the manufacturer's instructions.

Temperature Controls

Each unit ventilator shall be furnished with a factory installed and wired, microprocessor based DDC Unit Ventilator Controller (UVC), by the manufacturer of the unit ventilator, which is pre-programmed, factory pre-tested prior to shipment and capable of complete, stand-alone unit control, server-client arrangement or incorporation into a building-wide network using an optional plug-in communication module. The UVC shall be pre-programmed with the application code required to operate the unit using ASHRAE Cycle II. The unit control system shall include all required temperature sensors, input/output boards, main microprocessor modules, optional Local User Interface (referred to as LUI) Touch Pad with Digital LED Display, wiring, 24 volt power and direct coupled damper actuators. The UVC shall support up to 16 analog inputs, 8 binary inputs, 4 analog inputs, 2 PWM outputs, and 14 binary inputs.

Network System

1. The unit control system shall perform all unit control functions, unit diagnostics and safeties. The unit shall operate in the standalone or network capable mode of operation. Standalone units to have on-board BACnet MS/TP communication built in. Field furnished and installed controls shall not be allowed. When network capable, network communication module shall be factory installed, tested and able to communicate via plug-in communication module that connect directly to the UVC using:
 - a. BACnet Client-Server/Token Passing (MS/TP) allowing the UVC to inter-operate with systems that use the BACnet (MS/TP) protocol with a conformance level of 3 meeting the requirements of ANSI/ASHRAE 135- 2008 standard for BACnet systems.
 - b. LONMARK space comfort control that supports the LONMARK SCC profile number 8500-10 allowing LONWORKS network communication capability to the UVC.
2. Unit controls shall allow for monitoring and adjustment via Daikin ServiceTools using a PC with Windows® 7 or newer operating systems. When using this PC and software, the unit shall be capable of reacting to commands for changes in control sequence and set points.

Room Temperature Sensor

All units shall come equipped with a factory mounted room temperature sensor located in a sampling chamber (front, center panel) where room air is continuously drawn through for fast response to temperature changes in the room. When using a remote wall-mounted temperature sensor the ability shall exist to simply disconnect the unit-mounted temperature sensor using the provided quick disconnect plug. The room temperature sensor and override switch shall (SELECT one):

- a. be unit mounted.
- b. be an optional wall mounted temperature sensor, with integral tenant override capability.

Wall Mounted Sensor with Tenant Override

A thermistor type temperature sensor with integral tenant override and status LED shall be furnished with the unit ventilators.

SELECT one:

- a. 6-button digital display sensor to show room temperature, fan speed (Auto/High/Medium/Low), system mode (Heat/Cool/Auto/Off), alarm, override and occupancy.
- b. 4-button digital display sensor with temperature display indicates, alarm, override and occupancy.

- c. The basic room sensor with adjustment (cool to warm) is used in conjunction with MicroTech equipped units. The sensor has an output for temperature, and LED status indication and includes an override reset button.
- d. The basic room sensor is used in conjunction with MicroTech equipped units. The sensor has an output for temperature, and LED status indication and includes an override reset button.

Night Controls

Night set-back/set-up control shall be provided by (SELECT one):

- a. An internal Daily Schedule provides two occupied times and two unoccupied times for each of the seven days of the week and one set for holidays. The operator may select the month and date when the holiday schedule is used by selecting a start date and the number of days to run for up to sixteen periods.
- b. The network DDC control system.

External Signal Connections

The unit shall have three (3) multi-pin External Signal Connection Plugs factory provided and pre-wired with short wire whips that are capped for field wiring of:

- a. Remote Wall Mounted Temperature Sensor.
- b. External Input Signals (by others) availability dependent upon unit configuration: unoccupied, remote shutdown, ventilation lockout, dew point/humidity, or exhaust interlock signals.
- c. External Output Options (by others) availability dependent upon unit configuration: motorized water valve open/close, fault indication signal, pump restart, exhaust fan on/off or auxiliary heat signal.

[Accessory] Outdoor Air Intake Louver

Intake louvers shall be in the quantity and size shown on the plans and specifications, and as manufactured by Daikin Applied.

[Accessory] Horizontal Blade Aluminum Louver

Aluminum masonry louver shall be constructed with horizontal chevron-type, heavy-gauge aluminum blades and aluminum frame. The standard aluminum alloy shall be suitable for color anodizing (by others) or for factory painting. Weep holes shall be provided in the louver frame. A diamond pattern mesh screen shall be furnished on the interior side of the louver. Expanded metal is not acceptable. Louver shall be fabricated of mill finish 6063-T5 aluminum. [Optional: Louver shall be (1) aluminum with clear anodized finish (2) aluminum with an oven-baked powder paint finish. (3) unpainted.]

[Accessory] Vertical Blade Louver

Vertical blade aluminum louver shall be constructed with double-break, aluminum blades for mounting in panel wall or masonry wall applications. The louver frame shall be

heavy-gauge aluminum, 2.14" deep in direction of airflow, and have weep holes along face of bottom edge. The standard aluminum alloy shall be suitable for color anodizing (by others) or for factory painting. A diamond pattern mesh screen shall be provided on the interior side of the louver. Louver shall be fabricated of mill finish 6063-T5 aluminum. [Optional: Louver shall be (1) aluminum with clear anodized finish (2) aluminum with an oven-baked powder paint finish (3) unpainted. A four-sided flange shall be provided around perimeter of intake of same material and finish as louver.]

[Accessory] Grille

Decorative aluminum intake grille shall be constructed of heavy-gauge 6063-T5 extruded aluminum with square holes to match the louver opening, maximizing the air opening. The grille shall come with holes for mounting to building exteriors. The standard extruded 6063-T5 aluminum shall be suitable for color anodizing (by others) or for factory painting.



Daikin Applied Training and Development

Now that you have made an investment in modern, efficient Daikin equipment, its care should be a high priority. For training information on all Daikin HVAC products, please visit us at www.DaikinApplied.com and click on Training, or call 540-248-9646 and ask for the Training Department.

Warranty

All Daikin equipment is sold pursuant to its standard terms and conditions of sale, including Limited Product Warranty. Consult your local Daikin Applied representative for warranty details. Refer to Form 933-430285Y. To find your local Daikin Applied representative, go to www.DaikinApplied.com.

Aftermarket Services

To find your local parts office, visit www.DaikinApplied.com or call 800-37PARTS (800-377-2787).

To find your local service office, visit www.DaikinApplied.com or call 800-432-1342.

This document contains the most current product information as of this printing. For the most up-to-date product information, please go to www.DaikinApplied.com.

Products manufactured in an ISO Certified Facility.